

CPYE

P/FRISK/30  
c.1

# Skeena Region



British  
Columbia  
**Fish &  
Wildlife**  
Branch

957,669  
Steelhead Management  
28d

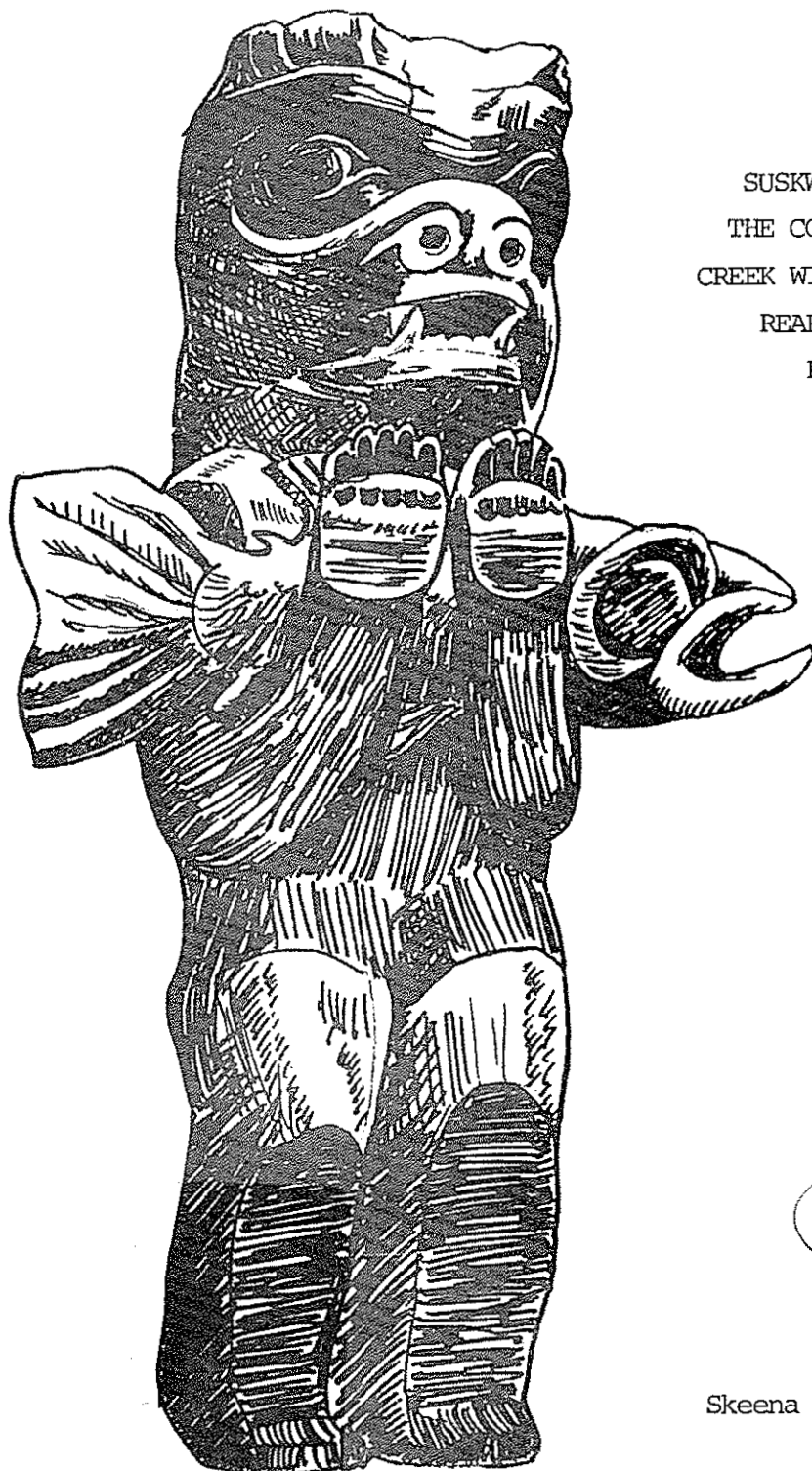

SUSKWA RIVER STEELHEAD TROUT:  
THE COLONIZATION OF HAROLD-PRICE  
CREEK WITH STEELHEAD FRY HATCHED AND  
REARED NEAR SKILOKIS CREEK  
PROGRESS REPORT-1980

By  
W.E. Chudyk

SK-30

Skeena Fisheries Report No. 80-1 (S.E.P.)  
March 1981.

P  
FR  
SK  
30  
c. 1 mm

P/FR/SK/30  
CHUDYK, W. E.  
SUSKWA RIVER STEELHEAD  
TROUT: THE COLONIZATION O  
CPYE c. 1 mm SMITHERS

SUSKWA RIVER STEELHEAD TROUT:  
The Colonization of Harold-Price Creek  
With Steelhead Fry Hatched and Reared  
Near Skilokis Creek.  
Progress Report - 1980

By  
W.E. Chudyk

Skeena Fisheries Report No. 80-1 (S.E.P.)  
British Columbia Fish & Wildlife Branch,  
Smithers, B.C.  
March, 1981.

## INTRODUCTION

To replenish depressed steelhead and other salmonid stocks provincially a joint Federal-Provincial cost sharing Salmonid Enhancement Program was created. Through S.E.P. the B.C. Fish and Wildlife Branch (Skeena Region) implemented a Suskwa River program designed to improve steelhead populations hence improve angler success. In two earlier reports (Chudyk, M.S. 1978 and Chudyk M.S. 1979) the author introduced the reader to the Suskwa study area and the steelhead fishery, presented the enhancement opportunities, and described the step by step procedures taken to colonize steelhead fry above Harold-Price Creek Falls in the upper Suskwa drainage.

This report deals with the following successive events leading to the colonization of steelhead fry into selected areas above Harold-Price Creek Falls in 1980:

1. The capture and holding of adult steelhead for brood stock,
2. The collection and incubation of steelhead eggs and the subsequent rearing of hatched fry,
3. The introduction of steelhead fry into selected sites above the Harold-Price Creek Falls, and
4. The assessment of steelhead fry dispersal and survival in Upper Harold-Price Creek.

## METHODS

### Adult Captures

Adult steelhead were angled from the lower Suskwa River

from March through May. Captured steelhead were tagged with green spaghetti tags, and then placed to mature sexually in two 1 X 1 X 2m frame "hatchery mesh" pens floated in a man-made pond located adjacent to Skilokis Creek, a tributary of the Suskwa River (Figure 1). Progressive records were kept on the physical condition of each fish. Water flow and temperature profiles for both Suskwa River and Skilokis Creek were recorded and are appended to this report.

On May 30 and again on June 11, 1980, sexually ripe female steelhead were spawned into a 10L container (Figures 2 and 3). Eggs were thoroughly mixed with sperm, water hardened, enumerated volumetrically, and placed in an upwelling incubation box over a matrix of graded, washed (2-4 cm) gravel (Figures 4 and 5). All spawned-out adults were held for a short time in the pens to recover prior to being released back into the Lower Suskwa River.

#### Fry Production

Alternating layers of fertilized eggs and gravel were placed in the incubation box. The eggs were spread as evenly and widely as possible to ensure a minimum of "touching". Water was then introduced to the bottom of the box in a manner which produced an evenly distributed upwelling flow pattern. After

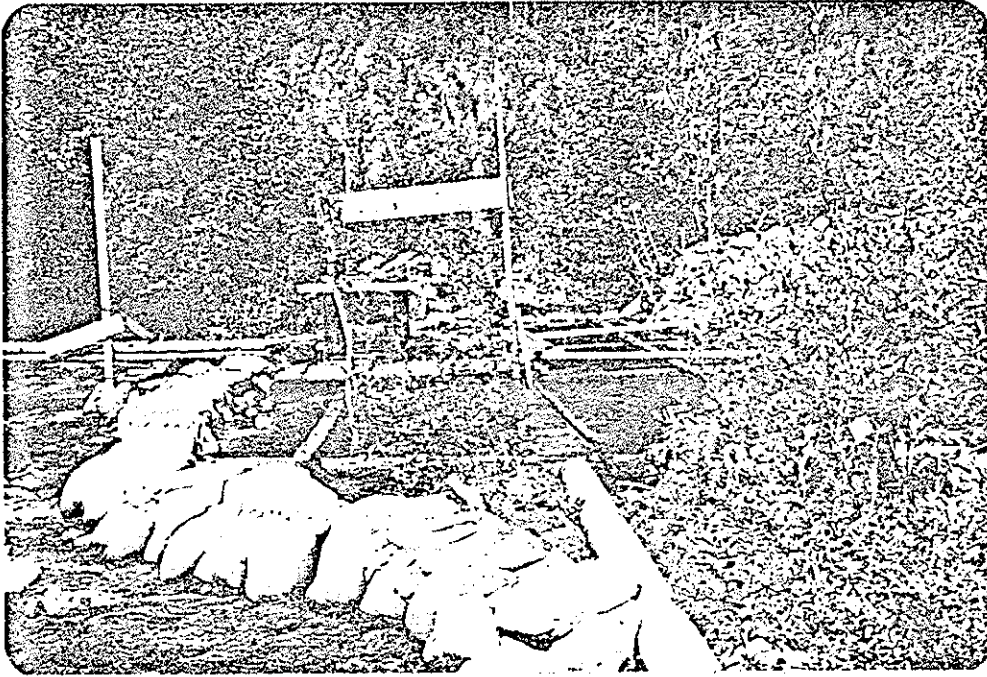

Figure 1. Skilokis Creek holding ponds.



Figure 2. Spawning adult female steelhead.



Figure 3. Spawning adult male steelhead.

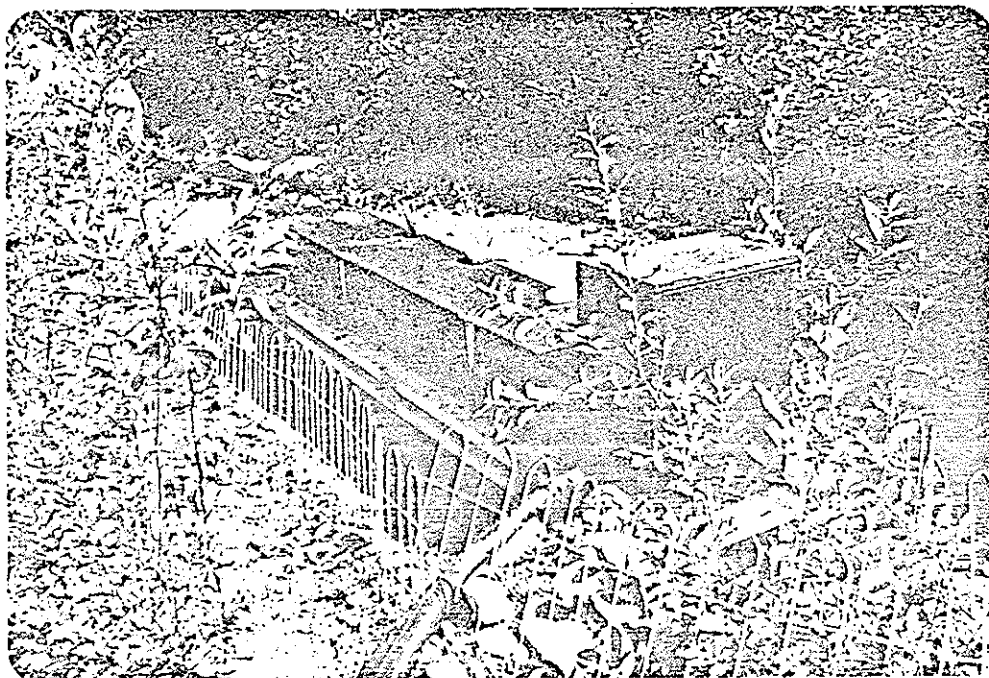

Figure 5. Upwelling incubation box

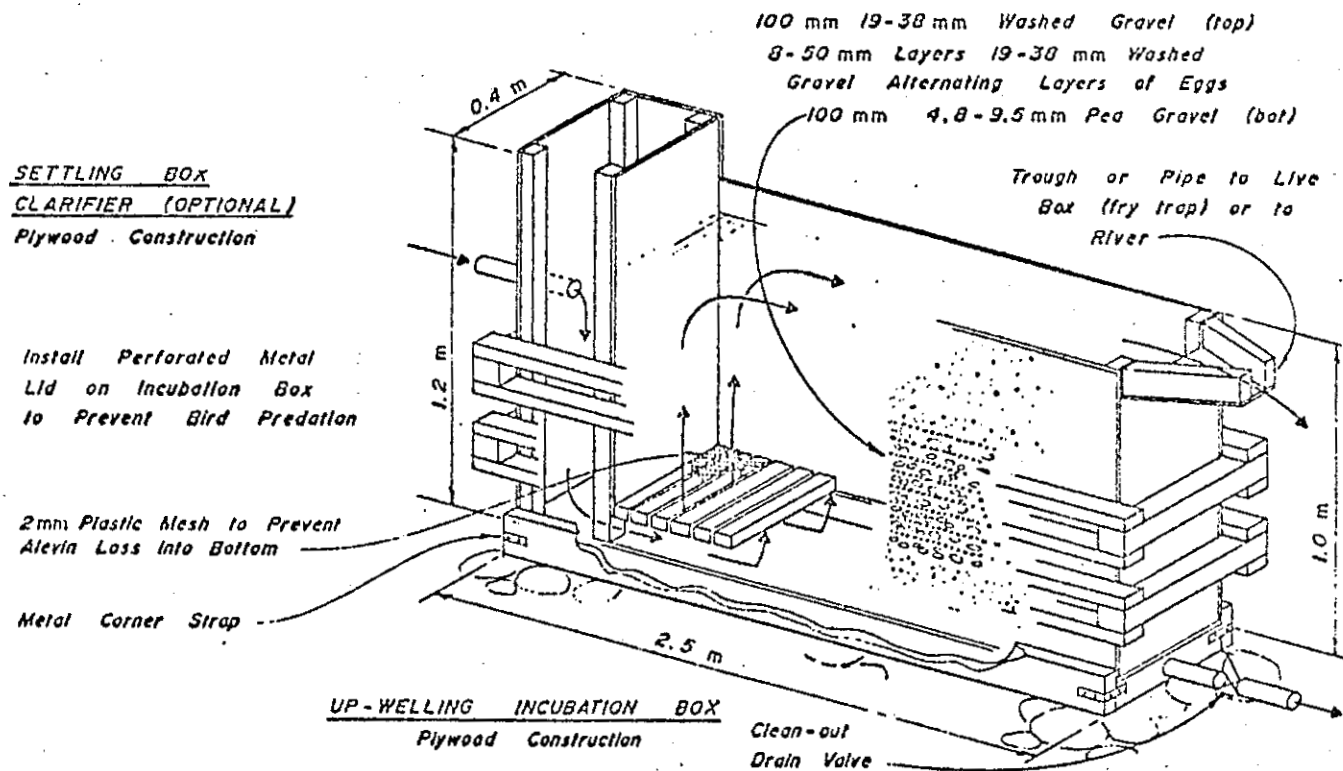

Figure 4. Up-welling incubation box used to incubate steelhead on the Suskwa River in 1980.

hatching and before yolk sacs were fully observed, fry emerging from the gravel swam or were carried by the upwelling current through the surface outlet to a screened live box. Emergent fry were enumerated and transferred into rearing troughs set up adjacent to the incubation box (Figures 6 and 7). Troughs were above ground (1 m) and covered with marquisette netting to discourage predators. From early August through to September 10, Fish and Wildlife Assistants fed fry half-hourly, treated fry with salt (NaCl), and monitored fry condition daily from dawn to dusk. Throughout the fry rearing operation Region personnel communicated regularly with Fish and Wildlife hatchery staff on fry feeding and condition and with the Branch fish pathologist on reasons for fry mortality and/or behavior.

#### Introduction of Hatchery Fish

Plastic garbage buckets equipped with an oxygen bubble system and filled with ice-cooled Skilokis Creek water were used to transport fry via helicopter to upper Harold-Price Creek. Fry were introduced to preselected areas above the renovated falls on the creek and dispersed in accordance with the .4 fry per square meter formula (S.E.R.C. M.S. 1980).



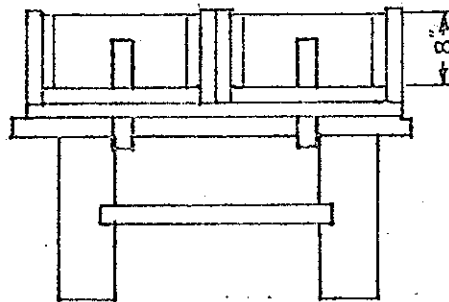
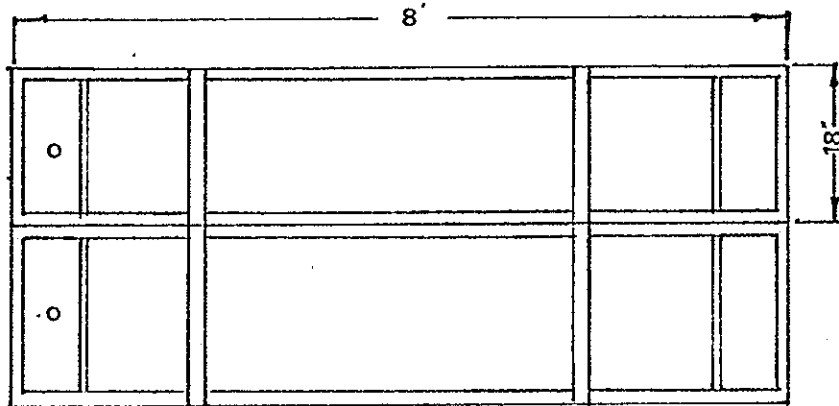
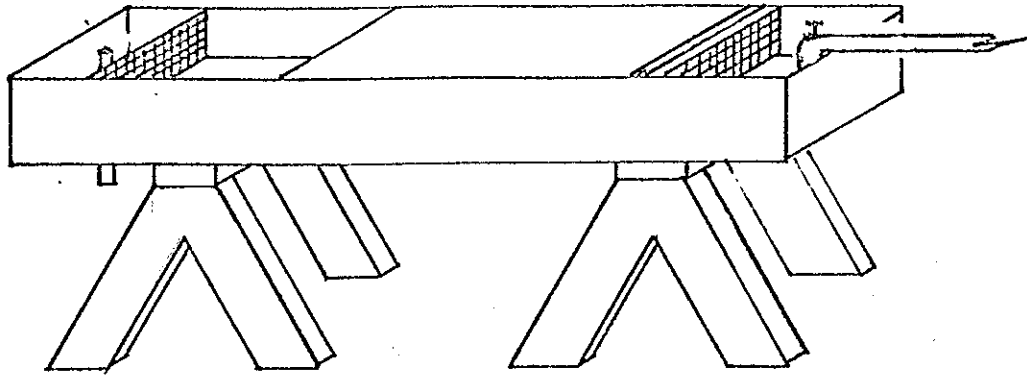

Figure 6. Rearing troughs used to incubate steelhead fry on Skilokis Creek, 1980.

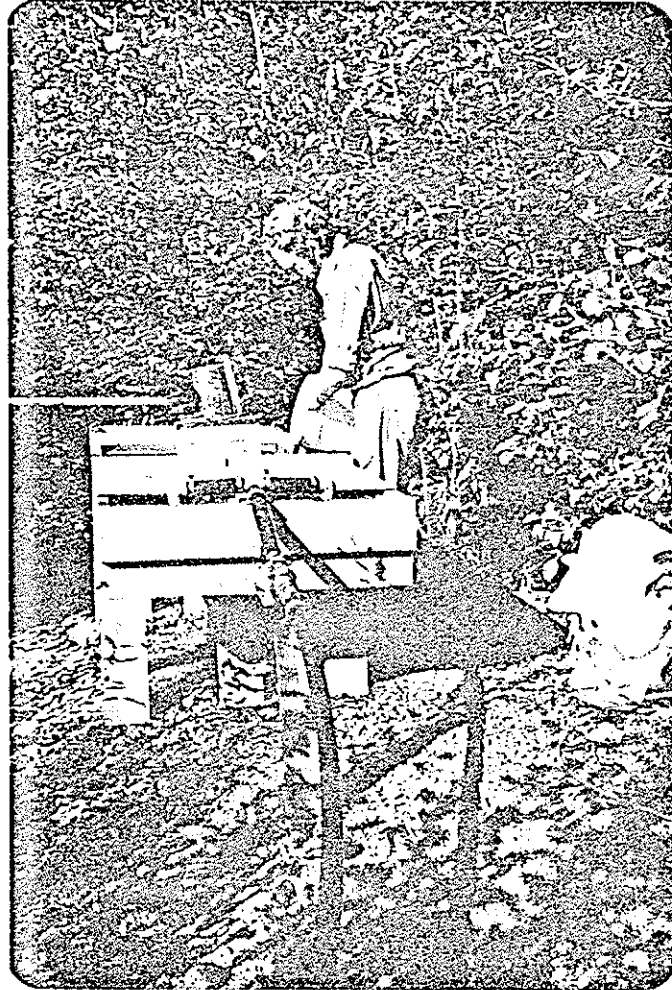

Figure 7. Rearing troughs.

## RESULTS

Of 14 steelhead angled from the lower Suskwa River, seven (4 females and 3 males) were used as brood stock (Table 1). The other seven fish either escaped (5), died (one to a river otter), or were captured as kelts (1) hence released. In two successive egg collections on May 30 and June 11, 15,570 eggs were taken, fertilized, water hardened and enumerated. Emergent fry numbered 12,749 (81%) after incubating for about 60 days or roughly 1150 temperature units (TUs). The two peak fry emergence days for the eggs taken on May 30 and June 11 were 2,716 on August 7 and 1,028 on August 14 respectively (Table 1 and Figure 9). After button-up and pin head mortality, 11,107 (70.5%) fry survived for introduction into Harold-Price Creek (Figure 8) and on September 11 the 1.5g fry were divided into three groups of about 5,500, 4,000 and 1,600 fish and colonized in the following locations (Figure 10):

- Site 1: 4,000 steelhead between the Harold-Price confluences of Maish and Tsouts Creeks.
- Site 2: 1,600 steelhead about 2.3 km below the confluence of Blunt and Harold-Price Creek.
- Site 3: 5,500 steelhead both up and downstream from the first Harold-Price bridge crossing.

## DISCUSSION

Both the 1979 and the 1980 fry releases fell short of the 80,000 target outlined in Chudyk (M.S. 1979). In 1979, fourteen steelhead died in holding pens before ripe enough to use as

Table 1. Sex, length, weight and history of steelhead trout angled from Suskwa River, 1980.

Cummulative Steelhead	Sex	Tag Number	Length (mm)	Weight (kg)	Date Captured	History
1	F	92	737	3.6	April 9	Eggs/May 30; Released June 2
2	M	40	813	4.5	April 9	Milt/May 30; Released June 13
3	M	41-42	762	4.1	April 9	Killed by River Otter
4	F	43	787	4.5	April 10	Escaped
5	M	45	622	2.3	April 10	Milt/May 30; June 11; Released June 13
6	F	44	902	7.2	April 18	Escaped
7	F	47	-	6.8	April 21	Escaped
8	F	48	711	3.6	April 26	Eggs/June 11; Released June 13
9	F	49-50	762	4.5	May 5	Eggs/May 30; Released June 2
10	M	161	-	1.8	May 22	Milt/May 30; Released June 13
11	F	251	762	4.5	May 22	Escaped
12	M	252	762	4.5	May 22	Escaped
13	F	254	762	3.6	May 24	Eggs/May 30; Released June 2
14	F	253	889	6.3	May 26	Kelt; Released May 26

Table 2. Total emergent (dead and surviving) steelhead fry with cumulative temperature units for two sequel egg takes from Suskwa River, 1980.

Date	Emergent fry	Cummulative Total emergent fry	Dead fry	Total (Live-Dead) fry	Cummulative Temperature Units (take #1)	Cummulative Temperature Units (take #1)
July 21	1	1		1	768	642
22	1	2		2	787	660
23	1	3		3	805	678
24	4	7		6	839	712
25	1	8	1	7	857	730
26	0	8		6	872	746
27	2	10	1	6	888	761
28	0	10	2	6	903	777
29	11	21		17	919	792
30	11	32		28	950	824
31	6	38		34	965	839
August 1	9	47		43	980	853
2	35	82		78	995	868
3	64	146		142	1012	885
4	169	315		309	1029	903
5	493	808	2	797	1050	924

Table 2. (con't)

Date	Emergent fry	Cumulative Total emergent fry	Dead fry	Total (Live-Dead) fry	Cumulative Temperature Units (take #1)	Cummulative Temperature Units (take # 1)
August 6	2150	2958	5	2947	1073	947
7	2716	5674		5663	1098	972
8	1736	7410		7399	1118	992
9	724	8134		8123	1139	1012
10	498	8632		8621	1169	1042
11	219	8851		8836	1193	1067
12	247	9098	4	9080	1214	1088
13	577	9675	3	9657	1234	1107
14	1028	10,703		10,683	1254	1128
15	750	11,453	2	11,433	1272	1146
16	473	11,926		11,904	1287	1161
17	473	11,926	2	11,904	1287	1161
18	321	12,247	4	12,221	1305	1179
19	130	12,377	3	12,348	1322	1195
20	89	12,466	2	12,435	1339	1212
21	71	12,537		12,506	1355	1229
22	57	12,594	1	12,562	1370	1243
23	64	12,658	2	12,624	1384	1257
24	28	12,686	8	12,644	1392	1265
25	19	12,705	24	12,628	1399	1274
26	3	12,708	19	12,609	1408	1283
27	6	12,714	52	12,563	1416	1291
28	16	12,730	183	12,390	1423	1301
29	2	12,732	10	12,291		
30	9	12,741	122	12,169		
31	5	12,746	96	12,078		
September 1	3	12,749	113	11,968		
2	0	12,749	155	11,813		
3	0		167	11,646		
4	0		167	11,479		
5	0		78	11,401		
6	0		122	11,279		
7	0		70	11,209		
8	0		49	11,160		
9			74			

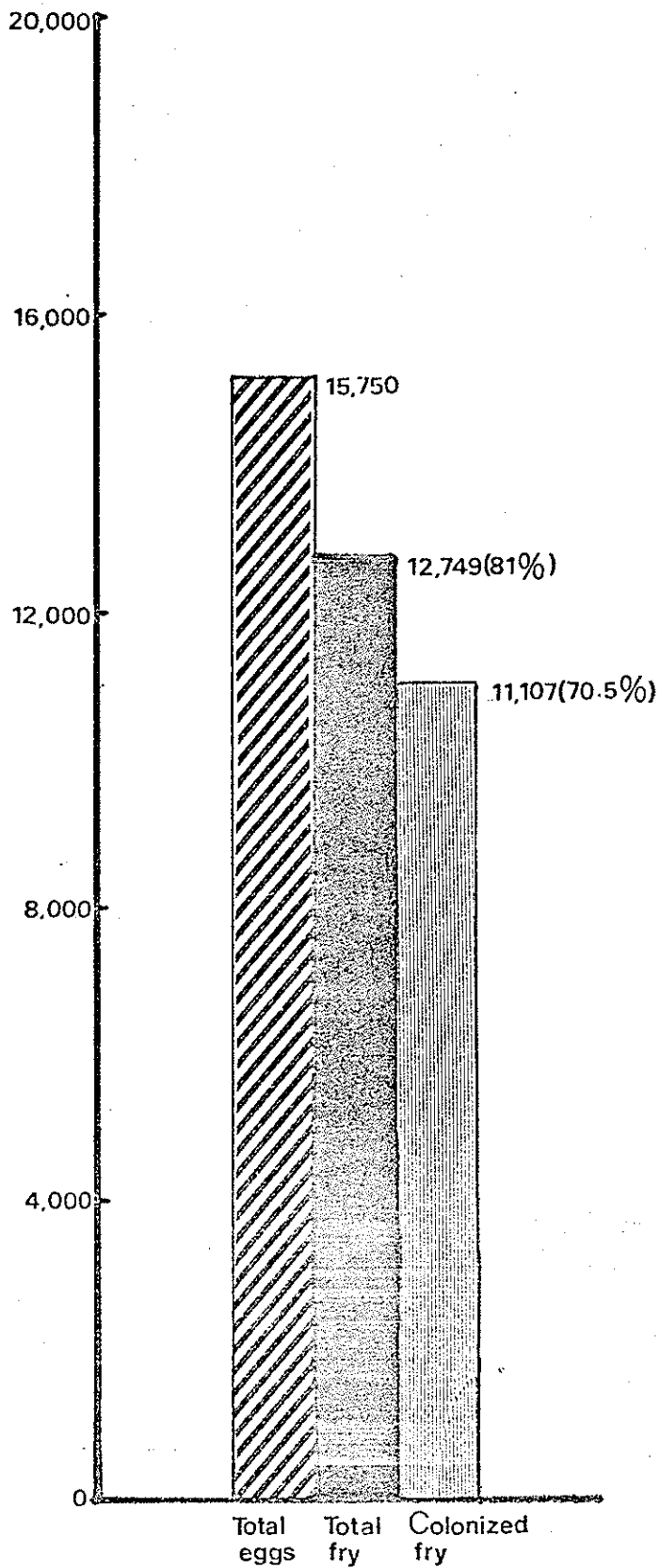

Figure 8. Total number of egg surviving to fry and fry colonized in Upper Harold-Price Creek, 1980.

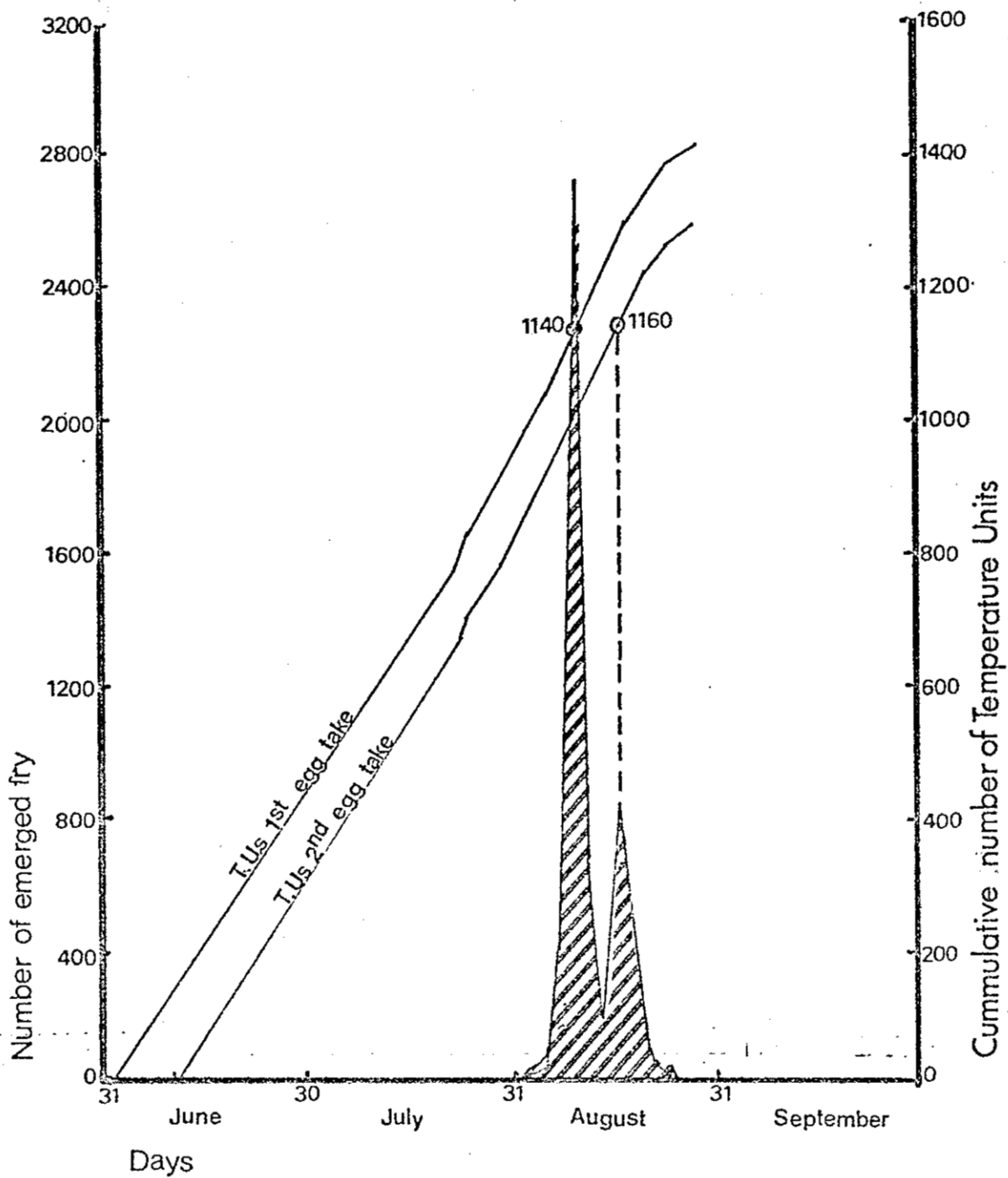

Figure 9. Number of temperature units needed for fry emergence from an incubation box on Skilokis Creek from May to August, 1980.

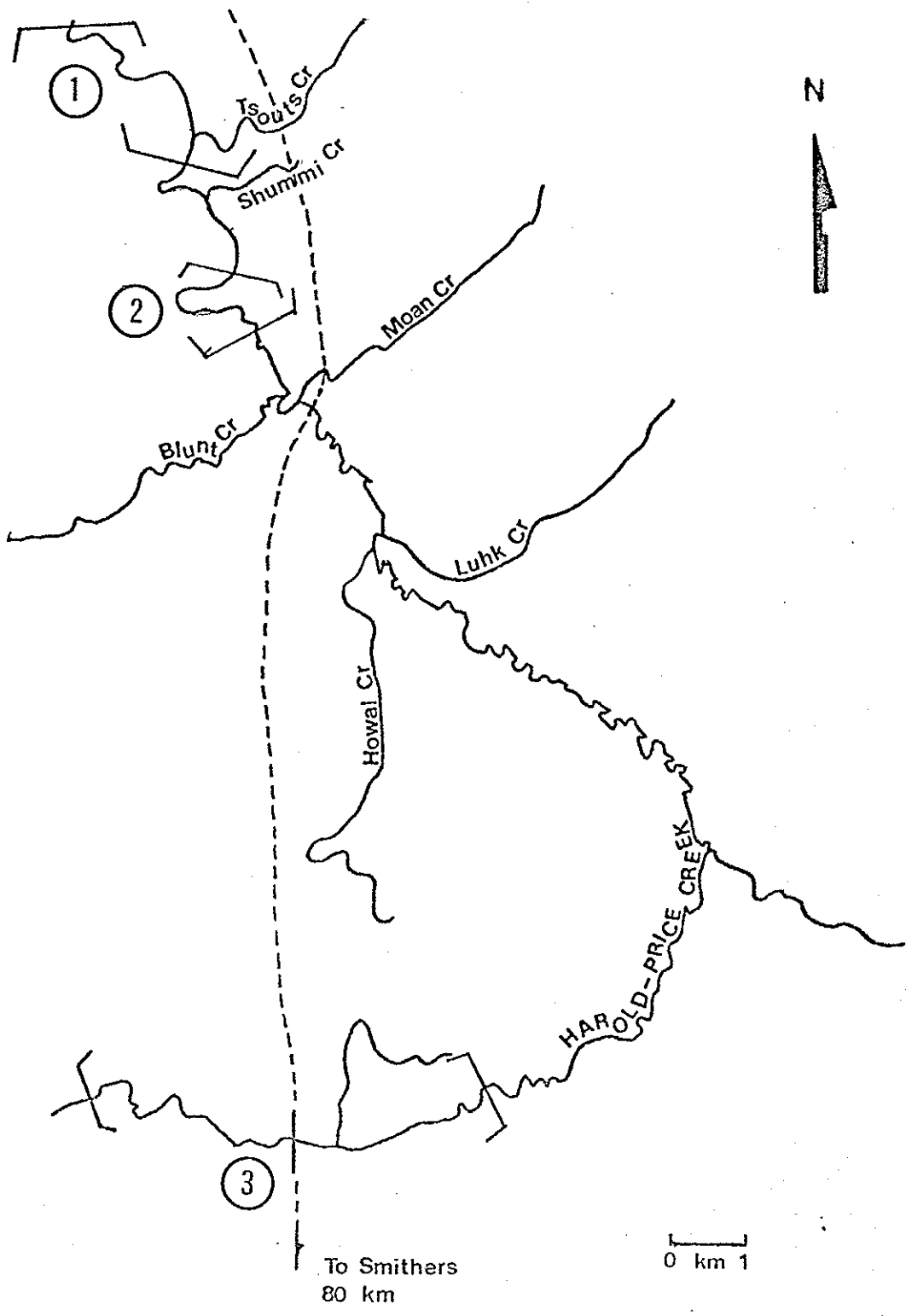

Figure 10. Upper Harold-Price Creek with steelhead colonization areas numbered.



broodstock. The heavy mortality was attributable to excessive handling and moving of holding pens made necessary by turbulence, current shifts and sediment load associated with sudden and heavy spring flooding on Suskwa River. In 1980 the improved offsite (Skilokis Creek) holding facilities drastically reduced adult mortalities, although sudden, early runoff in the Suskwa diminished the success of angling as a collection technique on an already low population of adult steelhead. Once again in 1981 with proven adult holding facilities, a new improved holding tube and a better (1980) return of steelhead, a sequel Suskwa operation will be undertaken.

In 1979 all eggs taken were shipped to Abbotsford Hatchery for incubation and rearing to the fry stage while in 1980 eggs taken were incubated and reared to fry on site. Due to colder Skilokis Creek water temperatures, the 1980 eggs hatched later and fry grew slower than Abbotsford-produced fry. Local fry at colonization weighed about 1.5 g whereas Abbotsford fry weighed 3.0 g. Fry survival to colonization was 69.5% in 1979 and 70.5% in 1980. By using two different techniques over two years it became apparent that the cost per fry produced, considering the time, weight, survival, and labour required to affect colonization, was much less for Abbotsford Hatchery raised fish. The main contributing factor relevant to the above was the labour aspect where one hatchery person handled many more times the eggs and

and fish than an equivalent local caretaker operating on Skilokis Creek. In 1981 hatchery facilities will again be used if time and space are available.

Several authors (Parkinson, M.S. 1970; Tredger M.S. 1980; Tolmey, B.S. 1979, and S.E.R.C. 1980) maintain that introduced fry should be dispersed manually at a rate of .4 per square meter over selected habitat. In 1979 attempts for wide dispersal were cut short by the emergency of a local forest fire. In 1980, however, fry were introduced in accordance with the above recommended procedure. Unfortunately, electroshocker, snorkel, and gee trap surveys on fry dispersal at time of writing were inconclusive. However, continued monitoring of introduced fry in Harold-Price Creek is a priority in 1981.

If as in 1979 we assume that four percent of 12,000 fry survive to become smolts and of ocean migrants four percent survive to return as adult steelhead then about 19 steelhead of the 1980 brood plus 24 of the 1979 brood year will be available in the angler fishery between 1982 and 1986. Hopefully, 1981 egg collections of 110,000 (using 1979, 1980 assumptions) will return about 176 adult steelhead between 1983 and 1987.

## SUMMARY

1. Fourteen adult steelhead were angled from the Suskwa River of which seven, four females and three males, were used as brood stock.
2. From the seven brood adults about 11,107 (70.5%) fed fry were produced from 15,750 eggs incubated near Skilokis Creek a tributary of the lower Suskwa.
3. 11,107 fry were colonized into four designated areas above Harold-Price Creek falls.

## FUTURE WORK

1. Continued monitoring of selected juvenile habitat for marked and unmarked introduced steelhead to determine survival and dispersal.
2. A sequel collection with introduction of hatchery reared fry above the falls of Harold-Price Creek will begin in early 1981.
3. An intensive creel survey will be conducted to determine whether or not improved Creel returns are in evidence as a result of the Suskwa program.

#### REFERENCES AND LITERATURE CITED

- Chudyk, W.E. M.S. 1978. Suskwa River steelhead trout: the 1977 inventory, creel survey and life history characteristics study leading to the removal of a barrier on Harold-Price Creek. Unpubl. M.S. Fish and Wildlife Branch, Smithers, B.C. 21 pp.
- Chudyk, W.E. M.S. 1979. Suskwa River steelhead trout: the colonization of Harold-Price Creek with hatchery-reared steelhead. Unpubl. M.S. Fish and Wildlife Branch, Smithers B.C. 15 pp.
- Parkinson, E. M.S. 1978. Evaluation of Headwater stocking of steelhead fry in coastal British Columbia. Unpubl. S.E.P. progress report, Fish and Wildlife Branch, U.B.C. Vancouver, B.C. 14 pp.
- Ptolmey R.A. M.S. 1979. Preliminary data for Colquitz Creek enhancement. Unpubl. S.E.P. progress report, Fish and Wildlife Branch, Victoria, B.C.
- Stream Enhancement Research Committee, M.S. 1980. Chinook coho and steelhead production capability estimates for S.E.P. planning. Unpubl. S.E.P. report, Fish and Wildlife Branch, Victoria, B.C. 29 pp.
- Tredger, C.D. M.S. 1980. Chinook and steelhead stocking densities in Bonaparte River. Unpubl. S.E.P. progress report, Fish and Wildlife Branch, Victoria, B.C. file copy.

APPENDICES

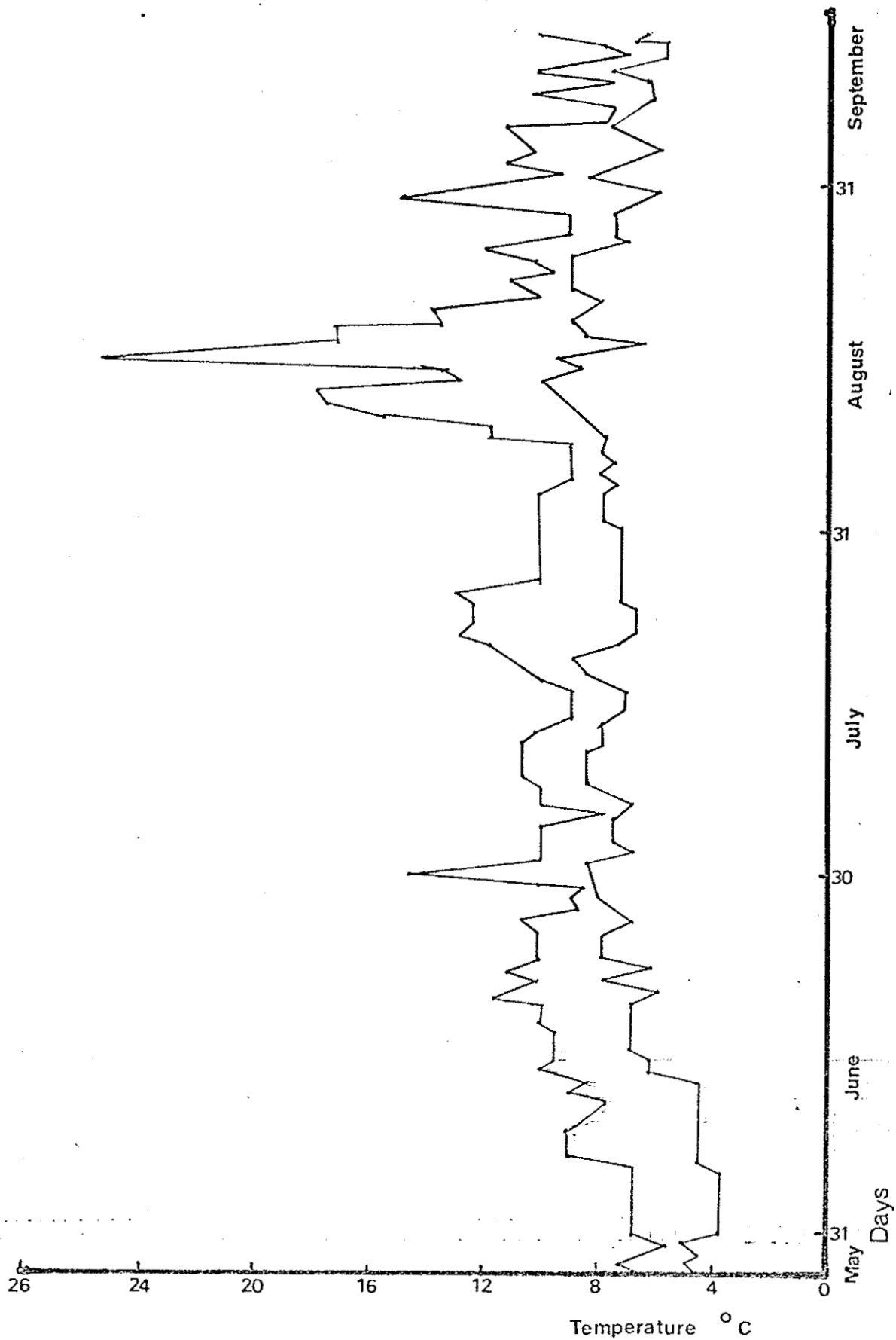

Figure 1. Maximum-minimum temperature fluctuations from the head tank on the Skilokis Creek incubation box from May to September, 1980.

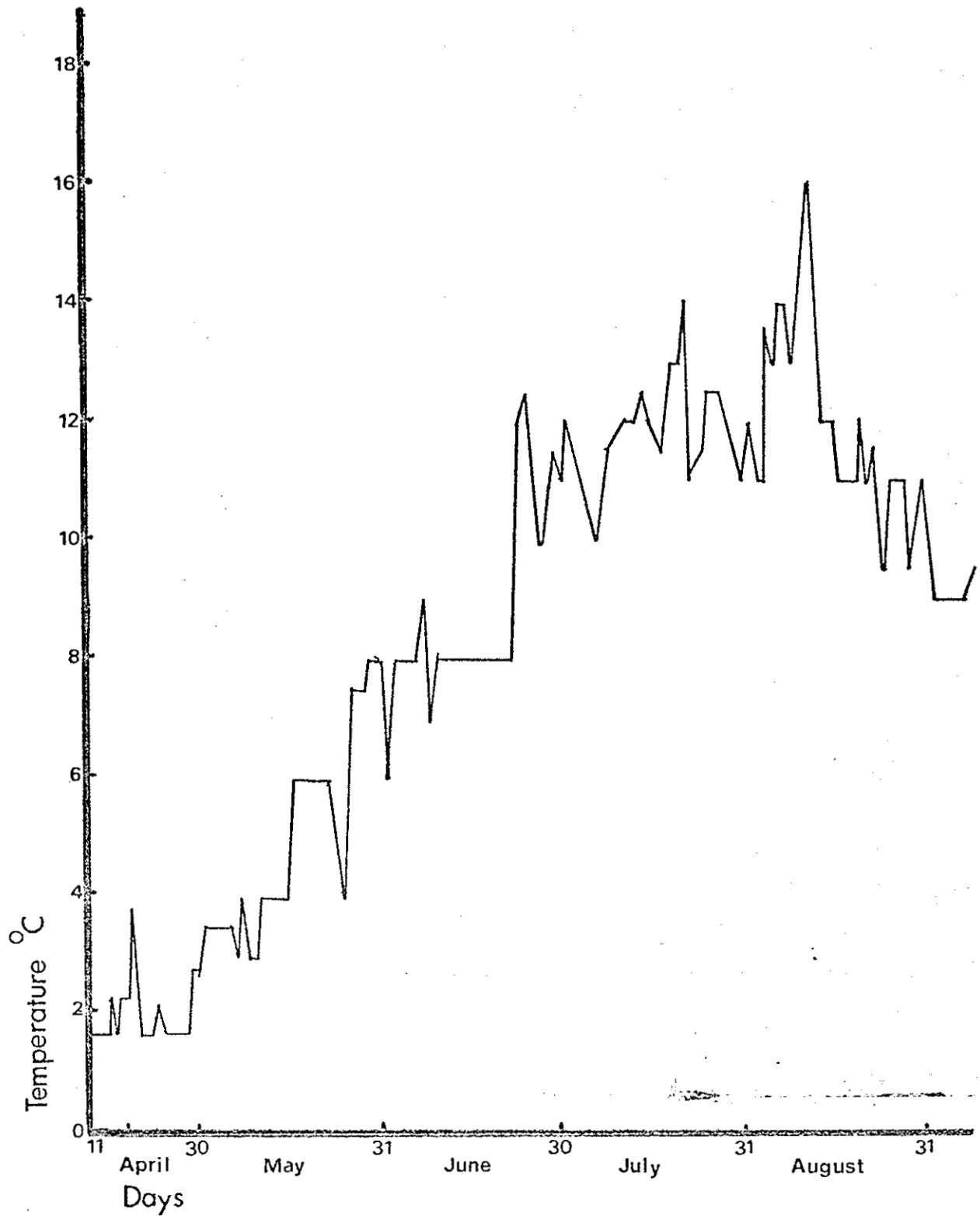

Figure 2. Lower Suskwa River daily temperature changes from April to September, 1980.

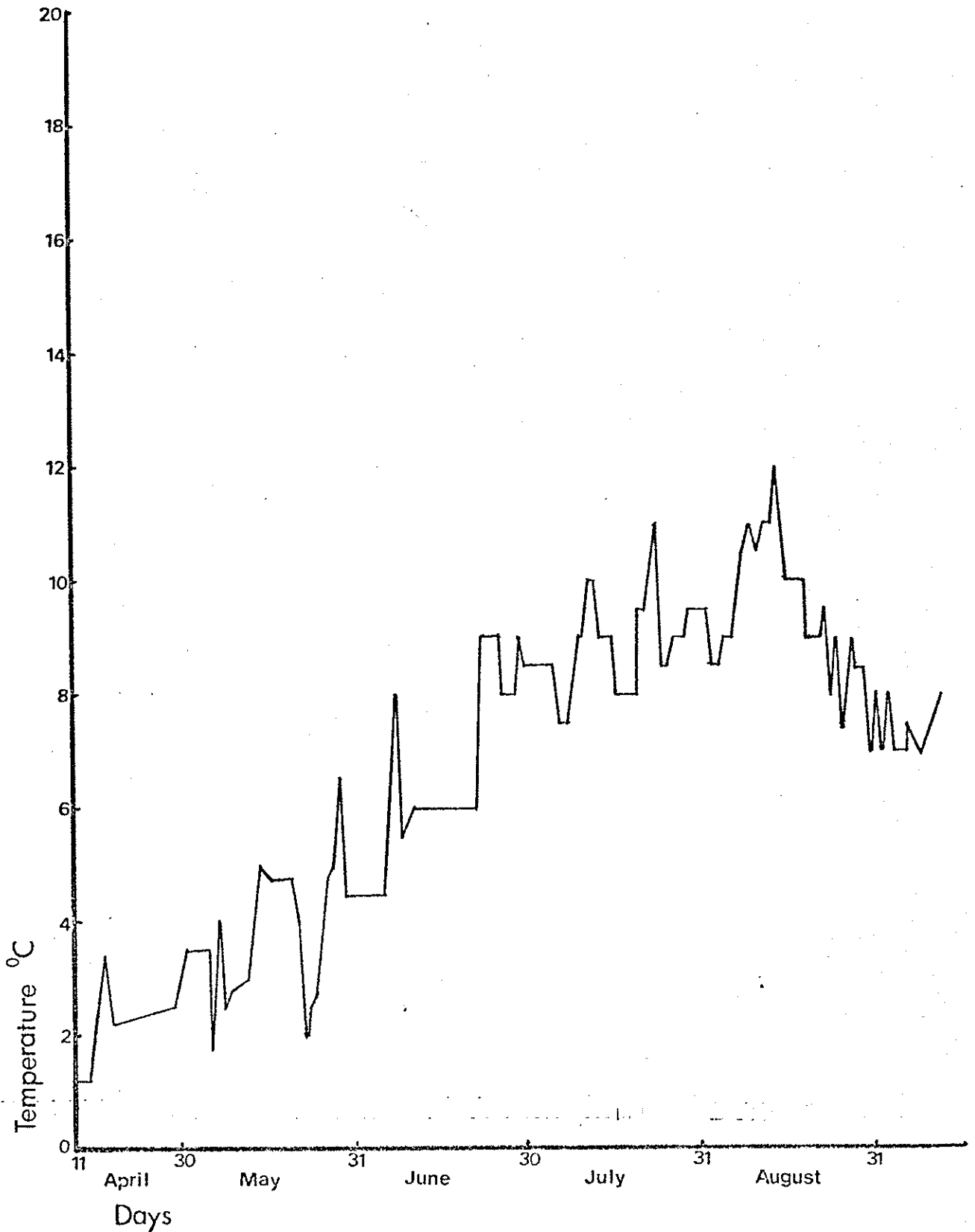

Figure 3. Skilokis Creek daily temperature changes from April to September, 1980.



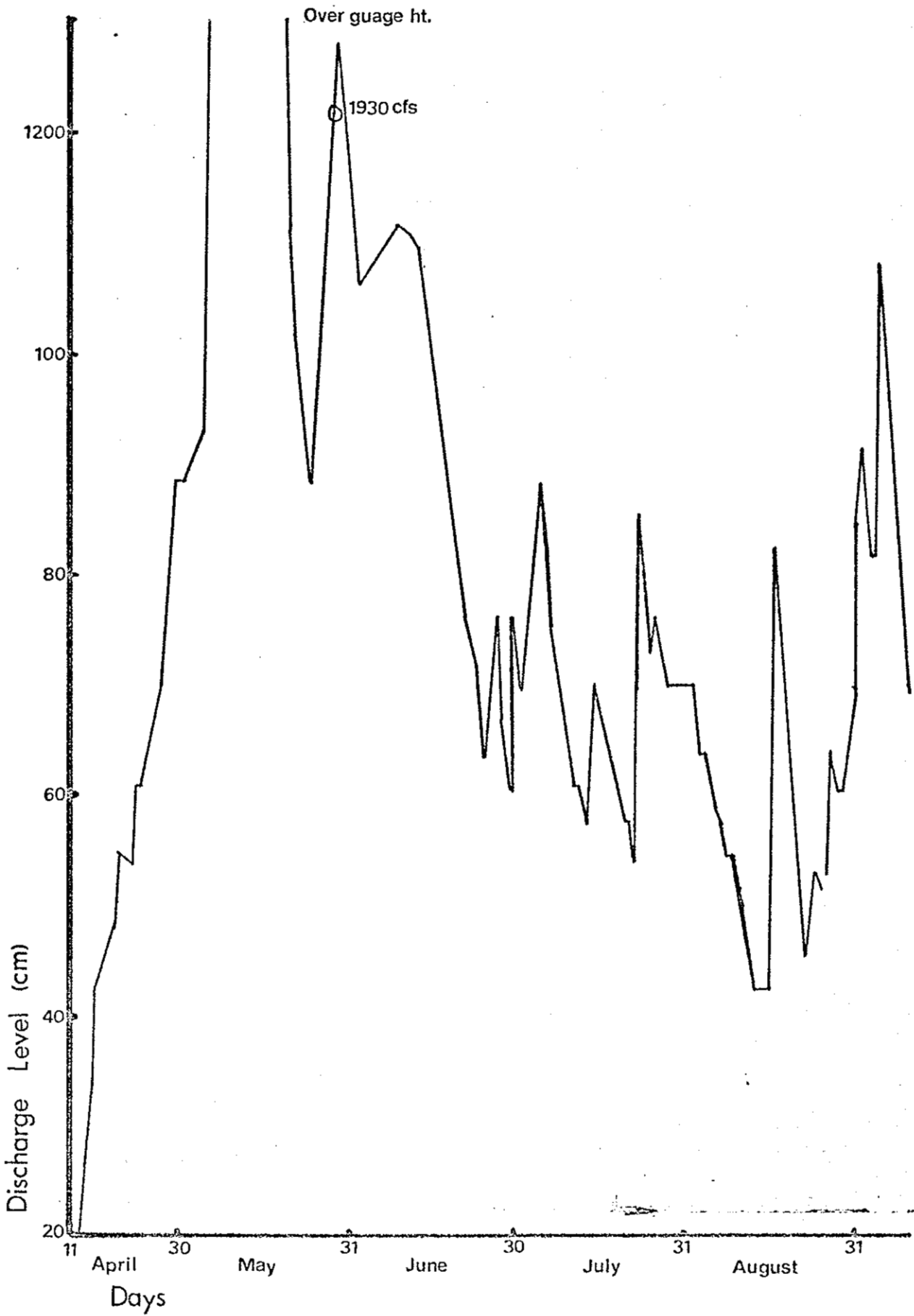

Figure 4. Lower Suskwa River daily discharge levels from April to September, 1980.

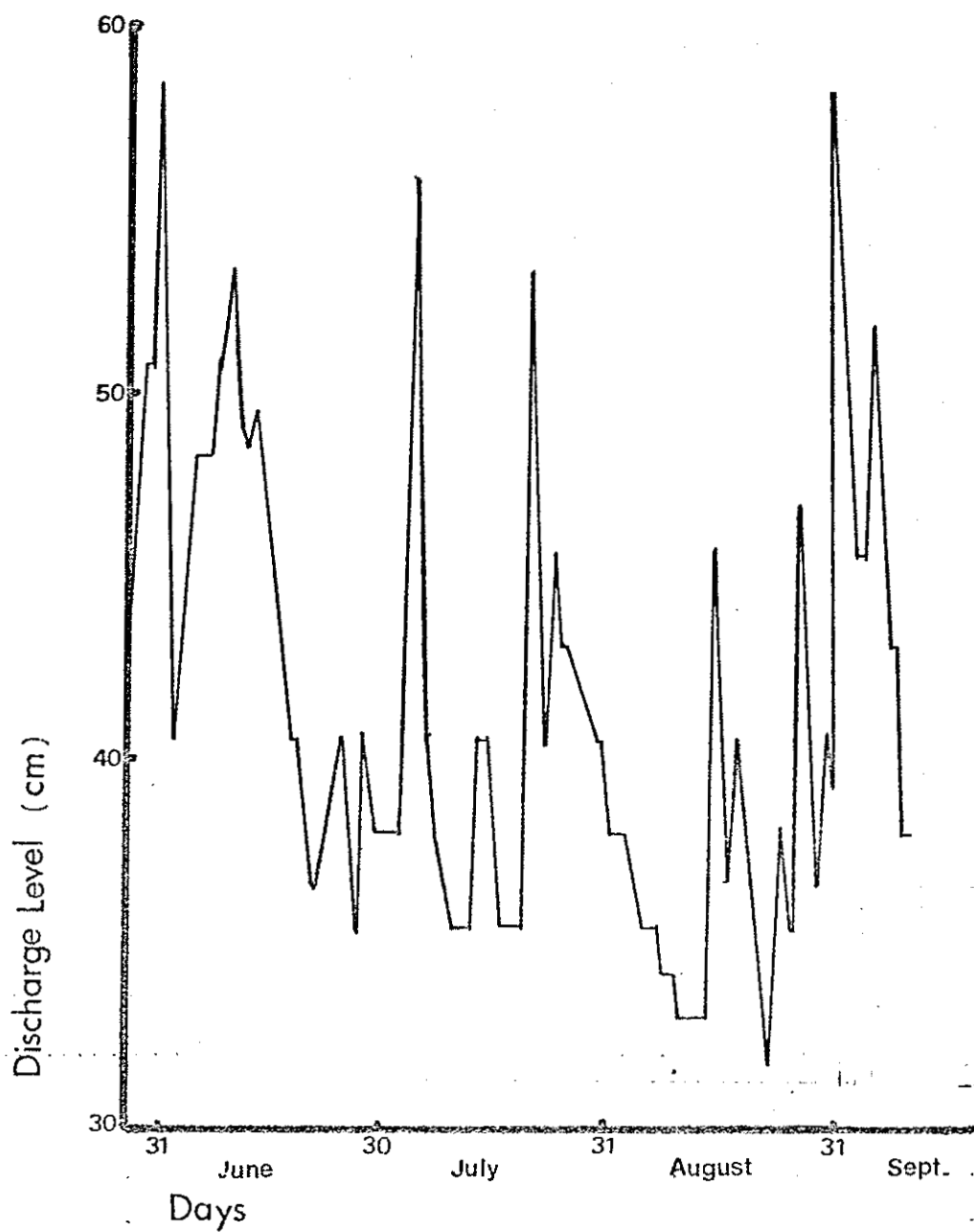

Figure 5. Skilokis Creek daily discharge levels from May to September, 1980.