

NOAA Technical Memorandum NMFS-NWFSC-29



Estuarine and Ocean Survival of Northeastern Pacific Salmon

**Proceedings of the Workshop
March 20-22, 1996
Newport, Oregon**

April 1997

**U.S. DEPARTMENT OF COMMERCE
National Oceanic and Atmospheric Administration
National Marine Fisheries Service**

NOAA Technical Memorandum NMFS

The National Marine Fisheries Service's Northwest Fisheries Science Center uses the NOAA Technical Memorandum series to issue informal scientific and technical publications when complete formal review and editorial processing are not appropriate or feasible due to time constraints. Documents within this series reflect sound professional work and may be referenced in the formal scientific and technical literature.

The NMFS-NWFSC Technical Memorandum series of the Northwest Fisheries Science Center continues the NMFS-F/NWC series established in 1970 by the Northwest Fisheries Center. The NMFS-AFSC series is now being used by the Alaska Fisheries Science Center.

This document should be cited as follows:

Emmett, R. L., and M. H. Schiewe (editors). 1997. Estuarine and ocean survival of Northeastern Pacific salmon: Proceedings of the workshop. U.S. Dep. Commer., NOAA Tech. Memo. NMFS-NWFSC-29, 313 p.

Reference in this document to trade names does not imply endorsement by the National Marine Fisheries Service, NOAA.

NOAA Technical Memorandum NMFS-NWFSC-29



Estuarine and Ocean Survival of Northeastern Pacific Salmon

**Proceedings of the Workshop
March 20-22, 1996
Newport, Oregon**

Edited by
Robert L. Emmett and Michael H. Schiewe

National Marine Fisheries Service
Northwest Fisheries Science Center
Coastal Zone and Estuarine Studies Division
2725 Montlake Blvd. E., Seattle, WA 98112-2097

April 1997

U.S. DEPARTMENT OF COMMERCE

William M. Daley, Secretary

National Oceanic and Atmospheric Administration

D. James Baker, Administrator

National Marine Fisheries Service

Rolland A. Schmitt, Assistant Administrator for Fisheries

This document is available to the public through:

**National Technical Information Service
U.S. Department of Commerce
5285 Port Royal Road
Springfield, VA 22161**

CONTENTS

Preface. <i>R. L. Emmett and M. H. Schiewe</i>	vii
Welcome. <i>U. Varanasi</i>	1
Keynote Address: Salmon Oceanography? <i>W. S. Wooster</i>	3
Special Topics in Salmonid Life Histories	7
Changes in Ocean Survival of Coho and Chinook Salmon in the Pacific Northwest. <i>R. Hilborn and C. Coronado</i>	9
Partitioning Mortality in Pacific Salmon. <i>M. J. Bradford</i>	19
Geographical Variation in Life Histories of Salmonids. <i>L. Weitkamp,</i> <i>P. Busby, and K. Neely</i>	27
Factors Influencing Freshwater and Marine Survival of Oregon's Coastal Coho Salmon--What We Know and What We Don't. <i>S. Johnson</i>	35
Decadal Scale Climate Pattern and Salmon Survival: Indicators, Interactions, and Implications. <i>J. J. Anderson</i>	43
Interannual Variations in Northeast Pacific Marine Habitats and the Effects on Marine Survival of Salmonids	55
Coastal Ocean Circulation Off Oregon: Recent Observations of Spatial and Temporal Variability. <i>J. A. Barth and R. L. Smith</i>	57
The Food Environment of Juvenile Salmonids: Year-to-Year Variations in Zooplankton Abundance Over the Inner-middle Shelf Off Central Oregon--1969-78. <i>W. T. Peterson</i>	69
Interannual Variability in Growth and Survival of Chinook and Coho Salmon. <i>P. W. Lawson</i>	81

Decadal Variations in Northeast Pacific Marine Habitats and the Effects on Marine Survival of Salmonids	93
Regime-scale Fluctuations in the Circulation of the North Pacific. <i>R. H. Parrish</i>	95
Decadal-scale Environmental Variability in the Coastal Northeastern Pacific. <i>F. B. Schwing, R. Parrish, and R. Mendelsohn</i>	105
Regime Scale Climate Forcing of Salmon Populations in the Northeast Pacific--Some New Thoughts and Findings. <i>R. C. Francis and S. R. Hare</i>	113
Process and Mechanisms--Estuarine	131
The Relationship of Estuarine Primary and Secondary Productivity to Salmonid Production: Bottleneck or Window of Opportunity? <i>C. A. Simenstad</i>	133
Estuarine Survival of Salmonids: The Importance of Interspecific and Intraspecific Predation and Competition. <i>R. L. Emmett</i>	147
Criteria for Evaluating the Survival Value of Estuaries for Salmonids. <i>C. D. Levings and D. Bouillon</i>	159
Estuarine Pollution and Juvenile Salmon Health: Potential Impact on Survival. <i>E. Casillas, B. B. McCain, M. Arkoosh, and J. E. Stein</i>	169
Process and Mechanisms--Nearshore Coastal	181
Factors Influencing the Marine Survival of Pink Salmon in Prince William Sound, Alaska. <i>R. T. Cooney and T. M. Willette</i>	183
The Importance of Various Spatial and Temporal Scales in the Interaction of Juvenile Salmon and the Marine Environment. <i>R. D. Brodeur</i>	197
Climate-Ocean Changes and the Impacts on Young Salmon in the Strait of Georgia. <i>R. J. Beamish and C. Neville</i>	213
Early Ocean Survival of Salmon Off British Columbia and Impacts of the 1983 and 1991-95 El Niño Events. <i>B. N. Hargreaves</i>	221

Process and Mechanisms--Offshore Marine	223
Offshore Distribution and Migration Patterns and Ocean Survival of Salmon. <i>K. W. Myers</i>	225
Modeling Temporal and Spatial Patterns of Salmon Migration, Feeding, and Growth in the Northeast Pacific Ocean. <i>P. S. Rand, J. P. Scandol, and S. G. Hinch</i>	233
Patterns of Covariation in Components of Recruitment Among Sockeye Salmon Stocks in British Columbia and Alaska. <i>R. M. Peterman,</i> <i>B. J. Pyper, M. F. Lapointe, and M. D. Adkison</i>	243
Growth and Energetics of Salmon in the Sea. <i>D. W. Welch</i>	249
Working Groups	269
Working Groups Kickoff Address: What Have We Learned in the Last Decade? What Are Research Priorities? <i>W. G. Pearcy</i>	271
Report of Working Group on Partitioning Survival. <i>Chair: M. Bradford.</i> <i>Rapporteur: C. Levings</i>	279
Report of Working Group on Estuarine Habitat Problems and Research. <i>Chair: R. Emmett. Rapporteur: B. McCain</i>	283
Report of Working Group on Nearshore Habitats. <i>Chair: W. T. Peterson.</i> <i>Rapporteur: R. D. Brodeur</i>	289
Report of Working Group on Offshore Habitat Problems and Research. <i>Chair: Katherine Myers. Rapporteur: Steve Ignell</i>	297
Post-Workshop Reviews	301
List of Attendees with Photo	305



PREFACE

It has been 13 years since the last conference on biotic and abiotic factors affecting oceanic and estuarine survival of salmon. The proceedings from that meeting, "The Influence of Ocean Conditions on the Production of Salmonids in the North Pacific," edited by William Percy (1983), summarized existing information linking oceanic conditions and salmonid survival, distribution, and abundance. All four work groups at the 1983 meeting emphasized the need to understand the effects of ocean conditions on salmonid survival, and called for long-term studies of the marine environment.

Unfortunately, the recommendations from the 1983 meeting have gone largely unheeded. Although the salmon research community has continued to spend large amounts of time and funding on freshwater habitat issues, relatively little has been spent on estuarine and marine salmonid habitat issues. In the meantime, Northwest salmon populations have continued to decline, with "poor" ocean conditions often being acknowledged as playing some ill-defined role.

In an effort to once again highlight the importance of estuarine and oceanic residency to salmon survival and year-class strength, we convened a small group in the summer of 1995 to begin planning a workshop to bring together scientists whose research addresses some aspect of this important issue. Providing further impetus to our efforts were several recent reports, including the National Research Council's "Upstream: Salmon and Society in the Pacific Northwest" (1996) and the Snake River Salmon Recovery Team's "Final Recommendations for the National Marine Fisheries Service," which have highlighted the need to fully understand salmonid estuarine and marine life histories--not just because these environments are where salmonids spend most of their lives, but also because substantial mortalities occur there, and rigorous evaluations of freshwater salmonid enhancement projects require information on estuarine and ocean survival.

The workshop consisted of 25 presentations, organized in the following six sessions:

- 1) selected aspects of salmonid life histories
- 2) interannual variations in Northeast Pacific marine habitats and the effects on marine survival of salmonids
- 3) decadal variations in Northeast Pacific marine habitats and the effects on marine survival of salmonids
- 4) processes and mechanisms in estuarine habitats
- 5) processes and mechanisms in nearshore coastal habitats
- 6) processes and mechanisms in offshore marine habitats

On the final day of the workshop, four working groups were organized to identify and discuss critical research needs, formulate testable hypotheses, and identify potential research strategies to enhance understanding of the role of estuarine and oceanic habitats in salmonid survival.

Since the four work groups met independently, their results are presented in slightly different formats.

As with any scientific meeting, the ultimate success depended largely on the thoughtful planning of the steering committee. For the 1996 Newport workshop, "Estuarine and Ocean Survival of Northeast Pacific Salmon," the steering committee was composed of Dr. George Boehlert of NMFS's Southwest Fisheries Science Center, Dr. Robert Francis of the University of Washington, Dr. Steve Ignell of NMFS's Alaska Fisheries Science Center, Dr. William Pearcy of Oregon State University, and Drs. Michael Schiewe and William Peterson, and Mr. Robert Emmett of the Northwest Fisheries Science Center. Drs. William Peterson, Richard Brodeur, Michael Bradford, Colin Levings, Steve Ignell, and Bruce McCain, and Ms. Kate Myers served as chairs and rapporteurs for the working groups. Finally, Ms. Sharon Damkaer and Dr. David Damkaer greatly assisted with compiling, editing, and reviewing the manuscripts in these proceedings.

Although it has taken 13 years to reconvene a conference on oceanic and estuarine survival of salmon, the results perhaps justify the wait. More than 140 scientists, representing disciplines ranging from fisheries ecology to population dynamics, and physical and biological oceanography to climatology, spent three intellectually stimulating days listening to papers, engaging in discussion, and planning future collaborations. To all the participants, we extend our sincere thanks.

Robert L. Emmett and Michael H. Schiewe
Northwest Fisheries Science Center

WELCOME

I take great pleasure in welcoming you to this conference on estuarine and ocean survival of northwestern Pacific salmon. Both the topic of this conference and its location in Newport are very significant to the Northwest Fisheries Science Center (NWFSC). I think most of you know that just a few minutes south of here is the campus of Oregon State University's Hatfield Marine Science Center. The Hatfield Center also houses laboratories of the National Marine Fisheries Service (NMFS), the Environmental Protection Agency, and the Oregon Department of Fish and Wildlife. This setting provides an ideal opportunity to undertake cooperative research programs among the federal, state, and university scientists. We began capitalizing on that potential about a year ago, when we transferred a few of our Seattle researchers to the Newport laboratory. We have also been very fortunate to hire a small number of highly qualified scientists to work on two new research programs at Newport. The first is the west coast groundfish ecology and assessment program. The second is a program to develop research strategies on estuarine and ocean survival of both marine and anadromous fishes.

I am very pleased to be here because this conference allows scientists from different institutions and different disciplines to come together to discuss important issues regarding salmon survival. I think all of you are aware of the national attention focused on the declining salmon stocks in the Pacific Northwest. The salmon problem encompasses the entire West Coast. There is a great deal of concern that we scientists are focusing considerably more attention on certain problems and not enough on others. One of the areas that requires good scientific planning and effort is the understanding of the factors that affect estuarine and ocean survival of salmon.

Salmon, in the course of their natural life cycle, originate in fresh water, pass through estuaries, adapt to salt water, and travel long distances in the ocean before returning to their natal stream to spawn. This life-history strategy is very complex and demanding for the species to maintain, as well as difficult for the scientists to study. The salmon species also has to cope with a number of natural and human-induced habitat changes. When these anthropogenic changes are superimposed on natural upheavals, they cause major impacts on salmon survival. As a result, on the West Coast where environmental and anthropogenic changes have been catastrophic, we are seeing considerable decline in many salmonid populations.

Considering all of the stresses that we are putting on salmon and their habitats, it is amazing that we still have any salmon left. Nevertheless, I believe that with a combination of dedicated scientific effort, wise environmental effort, and good management, we can mitigate at least some of the major stresses that salmon are facing. Most of the attention so far has been on the alterations in fresh water, partly because the changes are much more obvious and easier to study and correct. However, it has become very clear that we need to focus on and develop considerable information about all stages and geographic phases of the salmon life history.

The importance of this information has been emphasized in the Snake River Recovery Team recommendations, in the NMFS-proposed Snake River Salmon Recovery Plan, and in the National Research Council's report. This is the right time for us to come together. I'm very thankful to Mike Schiewe and the steering committee, who have worked for the last 6-8 months to develop this agenda and to bring you all together here. I think it is time for us to identify the areas in which we presently have a lack of information and understanding, and what actions we should undertake collectively for the next few years. So I'm looking forward to your presentations and to the directions for new research that you will recommend. I'm very pleased that NMFS is able to sponsor this conference along with our colleagues at Oregon State University -- I am a strong believer in multi-disciplinary efforts to address and develop innovative research strategies.

My own experience as a scientist, working for about 20 years on marine pollution issues, has shown that success has always occurred when scientists from different disciplines come together in somewhat untraditional alliances. I hope that the people who study natural processes, those who study anthropogenic stress, those who study biology, and those who study toxicology can come together. I think this is a good opportunity to develop some innovative strategies and a collaborative plan that we can all pursue for the next few years to come.

Thank you very much.

Usha Varanasi, Ph.D.
Director, Northwest Fisheries Science Center

KEYNOTE ADDRESS: SALMON OCEANOGRAPHY?

Warren S. Wooster

School of Marine Affairs
University of Washington
3707 Brooklyn Ave. N.E.
Seattle, WA 98105-6715

The last time I was in Newport, in 1983, was for a workshop on the influence of ocean conditions on the production of salmonids in the North Pacific. It arose from the idea that the environment in which salmon spend their oceanic years had some important effect on their survival and growth. At the time, we thought that interannual variability was the most important frequency--hence our book from a preceding workshop on nonsalmonid species was called *From Year to Year*. But since then, as today's lectures have made clear, many have come to believe that longer scales, decadal and beyond, are probably more important.

The preface to the 1983 salmon workshop report speaks of the devastating effects of the 1982-83 Niño event on ocean catches of coho and chinook salmon (*Oncorhynchus kisutch* and *O. tshawytscha*) off Oregon and Washington. More recently, I have even heard El Niño described as a "catastrophe." Like hurricanes and earthquakes perhaps, El Niño is only a catastrophe to the extent that it negatively affects humans. Otherwise, it is a particular feature of natural variability and may be as beneficial as it is harmful to the marine ecosystems that it influences. For example, salmon biologists have been forced since 1983 to contemplate the medium in which their favorite fish spend a critical part of their life history. Of course, that has not been sufficient to turn all salmon biologists into fishery oceanographers overnight.

When I came to the University of Washington (UW) nearly 20 years ago, I almost fell into the chasm that lay between Fisheries and Oceanography. It was my impression then that the College of Fisheries was interested mostly in salmon and oysters--not a bad combination if you are hungry, but not really representative of the broad scope of contemporary fishery problems. There was little interaction with the Department of Oceanography, which stood aloof from such messy problems. In contrast, I had spent much of my career at an institution on the edge of a pelagic realm, where interactions between fish and their environment were accepted as an article of faith, at least after Harold Sverdrup and Elton Sette had cooked up what became CalCOFI (California Cooperative Oceanic Fisheries Investigations), a program in which fishery scientists and oceanographers have comfortably cohabited for nearly 50 years.

Of course, there can be too much of a good thing. El Niño has become a convenient *deus ex machina* for all sorts of unexplained events, a curious viewpoint for those who normally see all stock variations as caused by man. In 1982-83, I was asked what El Niño would mean for salmon returns--I ventured a guess that the effect would be similar to that of the 1957-58 event, but I was left with the impression that no one had paid much attention to that. I tend to see El Niño not as some sort of plague but rather as an important climatic

signal that arises in the equatorial Pacific Ocean and sometimes extends into the subarctic Pacific, even into the Bering Sea, and in extra-tropical latitudes is usually associated with decreased upwelling, warming, and deeper thermoclines. These in turn influence primary and secondary production, distribution of both plankton and nekton, and growth and mortality of higher level carnivores, including salmon.

But El Niño is not the only influence on these factors, and in the case of fish that are harvested, the effects of fishing, not only on target stocks, but on their prey, predators, and competitors, have also to be taken into account. It is my impression that no one really understands how changes, however induced, in one important component of an oceanic ecosystem trickle down or bubble up to affect other components. The question comes to a head in what has been called the carrying capacity problem.

With the increase in the number and output of salmon hatcheries around the North Pacific rim, and with the observation of reduced growth (smaller size at age) of returning salmon, the question arises, "Is there a finite carrying capacity for salmon (and other high trophic level, pelagic carnivores) in the subarctic Pacific, and is it in danger of being exceeded?" A related question concerns whether carrying capacity is a constant, as tends to be assumed in the case of marine mammals, or whether it changes in response to climate variations. These questions led PICES (an international North Pacific organization comprising Canada, China, Japan, Korea, Russia, and the United States), in 1993, to initiate development of a GLOBEC program on Climate Change and Carrying Capacity, the so-called CCCC (four Cs) program.

From the beginning, considerable controversy arose over the definition of the term "carrying capacity." For purists, it was "k" in the exponential growth curve, what I call the "bugs in a bottle" approach, and could not be extended to ecosystems. Much of the thinking on these matters comes from terrestrial or other enclosed systems (e.g., lakes) and does not fit relatively open-ended systems such as those in the ocean. The debates led ultimately to a definition that I, at least, am comfortable with: "Carrying capacity for a given population is considered to be the limiting size of that population that can be supported by an ecosystem over a period of time and under a given set of environmental conditions."

The carrying capacity problem is a subset of a grander scientific question: "How are marine ecosystems of the subarctic Pacific Ocean affected over periods of months to centuries by changes in the physical environment, by interactions among components of the ecosystems, and by human activities?"

So how do you study such a vast problem? People find it difficult to think freely about this question because of the funding situations in which scientists here and in most other countries find themselves. Thinking is constrained by the perception that only limited resources are available to support such studies. Without new funding, the only solution is to reprogram existing funds, a prospect that strikes terror into most bureaucracies and causes them to develop elaborate defensive strategies. While some coastal programs are already

funded and under way, studies of the open subarctic Pacific Ocean, the main feeding ground for most salmon stocks, are much more difficult both to design and to fund.

Two relatively inexpensive approaches are probably the ways to begin, retrospective studies and modeling/theoretical studies. These are needed both to frame hypotheses and to design process studies and monitoring efforts. PICES is holding a CCCC Workshop on Conceptual/Theoretical Studies and Model Development in Nemuro, Hokkaido on 23-28 June 1996 and is convening a one-day symposium on Methods and Findings of Retrospective Analyses at its Fifth Annual Meeting in Nanaimo, British Columbia in October. PICES has a Working Group on Monitoring the Subarctic Pacific Ocean and a Technical Committee on Data Exchange--these will also support the CCCC program. The other desideratum at this early stage is a network of committees and study groups in which scientists participate in planning in a systematic way, achieving some sort of coordination among the different national GLOBEC and GLOBEC-like programs.

Development of an effective scientific program is colored by fishery politics, in the United States (Alaska vs. the rest of the country) and internationally. Salmon politics seem to be particularly virulent. In some countries, fishery agencies take the view that *all* research on salmon and ecologically related species--that is, everything else--is their exclusive property. Perhaps in those countries, fishery science is intimately linked with the other disciplines necessary for ecosystem studies--meteorology and climatology, oceanography of the several flavors (physical, chemical, biological), and ecology in the broader sense--but I have not seen any evidence of such a happy interdisciplinary, interinstitutional marriage there nor in most other countries. Yet it seems to me that without such a broad approach, the scientific questions that underlie those of more immediate interest to management are unlikely to be resolved.

Of course this tension goes beyond any single country. Many here work for government agencies charged with managing fisheries or with providing the scientific assessments used by the managers. Some such people tend to follow the accepted population dynamics paradigms and to be impatient with those who are more free to challenge them and to pursue other approaches without the day-to-day responsibilities of management. I remember hearing the director of one fisheries center refer to those in what I thought of as a particularly productive and insightful research group as "playing in an intellectual sandbox." I spoke earlier of the ancient schism between oceanographers and fishery scientists, and my experience at UW shows that the chasm remains despite more bridges across and more student interest in crossing those bridges.

I hope we can emerge from this workshop with the conviction that the scientific questions relating salmon growth and survival to oceanic and estuarine conditions are important to oceanographers as well as to fishery scientists, and that study of these questions calls for a full sharing of ideas and joint action among those who can bring their knowledge and skills to all facets of the question. Perhaps then we will be ready to celebrate the development of a field that might reasonably be called "salmon oceanography."



Special Topics in Salmonid Life Histories



CHANGES IN OCEAN SURVIVAL OF COHO AND CHINOOK SALMON IN THE PACIFIC NORTHWEST

Ray Hilborn and Claribel Coronado

Fisheries Research Institute
University of Washington
Seattle, WA 98195-7980

Abundance of salmon has fluctuated greatly. Figure 1 shows the fluctuation in landings of chinook (*Oncorhynchus tshawytscha*) and coho (*O. kisutch*) salmon in the United States. While we have tended to concentrate on the general decline of chinook and coho salmon from California to British Columbia, we should not lose sight of the fact that even in the 1970s there was a general perception that salmon stocks were declining, and in Canada the Salmonid Enhancement Program was begun with the objective of doubling the number of salmon.

We want to understand what causes the changes in abundance and what the impacts of alternative human actions will be. The traditional explanations for changes in salmon abundance have been the 4-Hs: habitat, harvest, hatcheries, and hydropower. We might therefore compare the trends in catch, escapement, total run, etc., to human action in one of these factors, or perhaps in several of them.

It has long been recognized that there is variability in ocean survival of salmon, and most analyses of human impacts on salmon will treat ocean survival as a form of uncontrolled noise that confounds the analysis. However, the increasing recognition of large-scale changes in ocean conditions suggests that we might need to do more than simply allow for random ocean survival, but rather try to measure it directly.

Since the early 1970s, there has been an extensive program of tagging Pacific salmon using coded wire tags. At present, approximately 30 million fish are tagged every year, and the salmon management agencies on the Pacific coast conduct an extensive tag recovery program. These data can be used to estimate the survival of tagged fish in the ocean. Coronado (1995) and Coronado and Hilborn (in prep. (a,b)) have used these data to describe the changes in ocean survival.

VPA Methodology

We used the estimated recoveries of commercially and recreationally caught fish, and the estimates of tagged fish in hatchery returns, to calculate the survival rate using virtual population analyses (VPA) (Hilborn and Walters 1992). For each species we calculated the estimated survival from time of ocean migration to age 3, the most common age of return for coho and fall chinook salmon. While VPA does require making an assumption about the rate

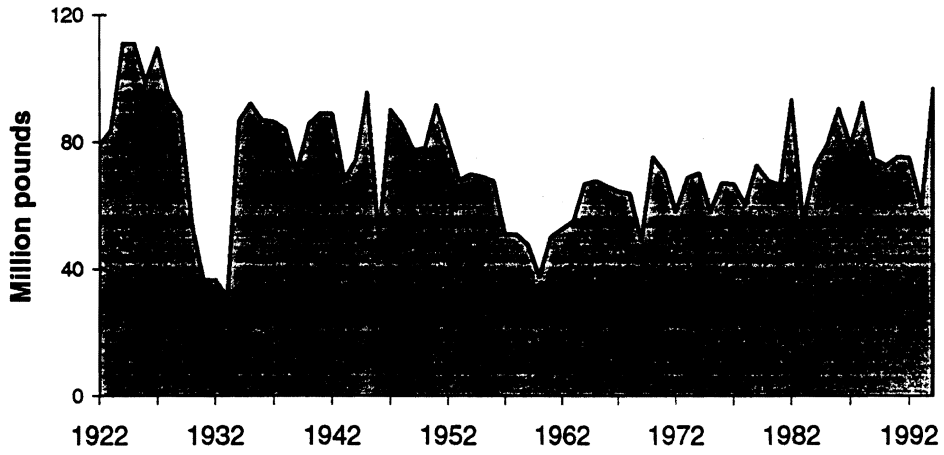

Figure 1. U.S. landings of coho and chinook salmon, 1922-92.

of natural mortality for fish in the ocean after age 1, all trends and relative survival are quite insensitive to these assumptions.

Trends

Figures 2 to 4 show the geographic trends in survival for coho and spring and fall chinook salmon by state and province. In each case, the vertical bars represent standard errors of the mean computed by using each tag code within the state or province for that year as a replicate sample. The shaded region represents total hatchery releases.

The trends in survival are both striking and geographically diverse. For instance, British Columbia coho salmon showed high initial survival in the early 1970s, followed by a steady decline through the 1980s to a level of about one-third of the initial survival. In contrast, Washington coho salmon showed steady survivals up until the 1987 brood year and then a decline after that. For fall chinook salmon, British Columbia and Washington showed reasonably similar trends, while Oregon and California were quite different. Spring chinook salmon showed yet a different pattern.

Within geographic regions, there tends to be considerable coherence. For instance, Figure 5 shows the trends in coho salmon survival for Columbia River hatcheries in Washington and Oregon. Even though the hatcheries are run by different agencies, the trends, particularly in the 1980s, are almost identical.

We have performed cluster analysis of survival trends for coho and fall chinook salmon, and the data tend to cluster by geographic region. We believe these trends reflect the survival in the early ocean life history of these fish, and this is, in turn, related to the general oceanographic production regime of the stock.

It is our contention that the survival rate reflects the early ocean survival, and what we see in the hatchery stocks reflects similar trends in wild fish. While the majority of coded wire tags are placed on hatchery fish, there has been some tagging of wild stocks. Figure 6 shows the trends in survival of wild and hatchery coho salmon. While far from conclusive, these data suggest to us that the trends in survival seen in the hatchery fish are likely a reflection of the survival of wild fish.

Management Implications

This analysis suggests that much of the fluctuation in abundance of chinook and coho salmon can be explained by changes in ocean survival. This does not mean, however, that we should ignore human impacts and simply hope for better ocean conditions. The major purpose of looking at ocean survival is to eliminate this form of variability from analysis when we consider modification of habitat, harvest, hatcheries, and hydropower.

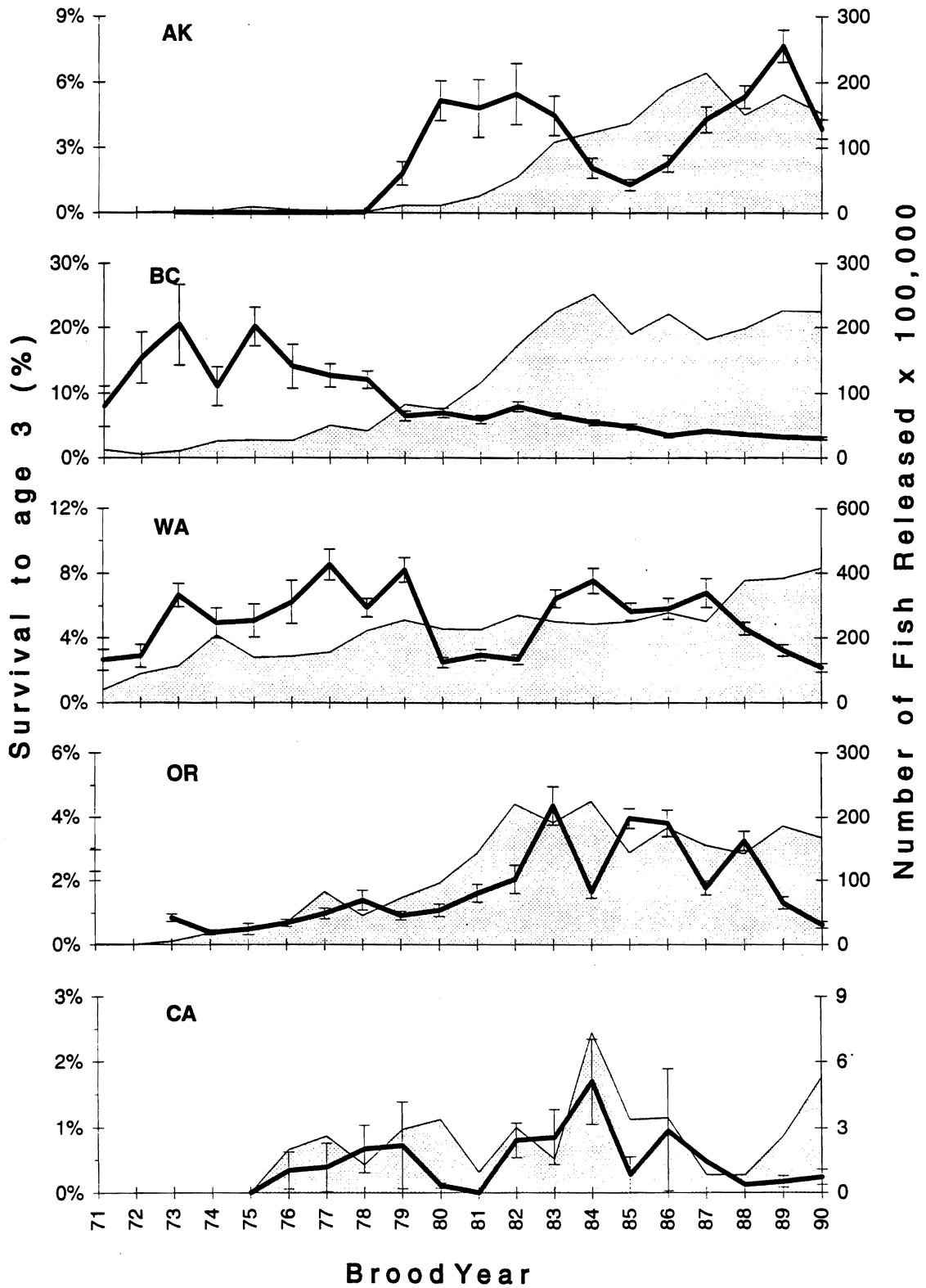

Figure 2. Survival trends for coho salmon. Line represents survival to age 3; error bars are the standard error of the mean; shaded area is number of fish released by brood year x 100,000.

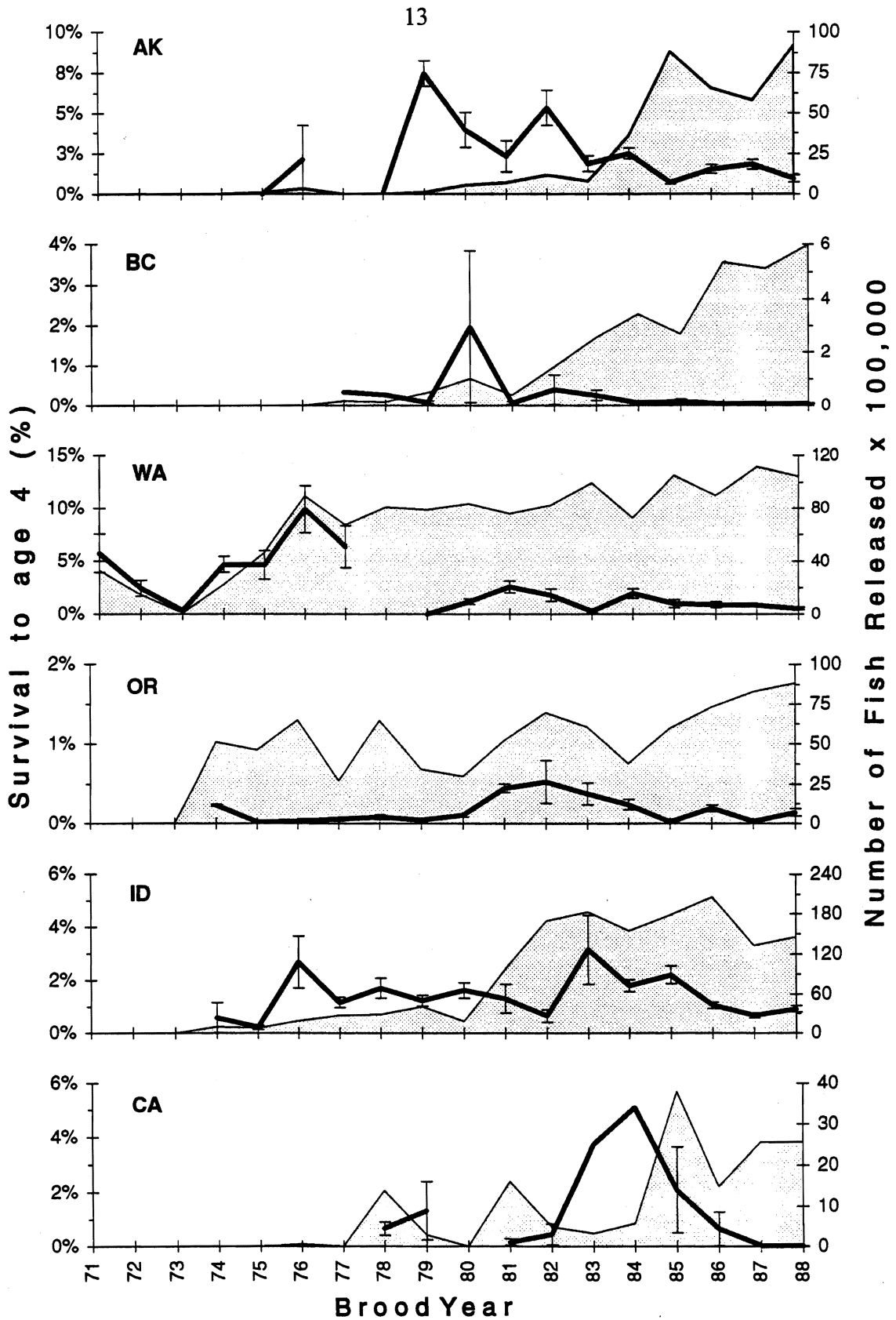

Figure 3. Survival trends for spring chinook salmon. Line represents survival to age; error bars are the standard error of the mean; shaded area is number of fish released by brood year x 100,000.

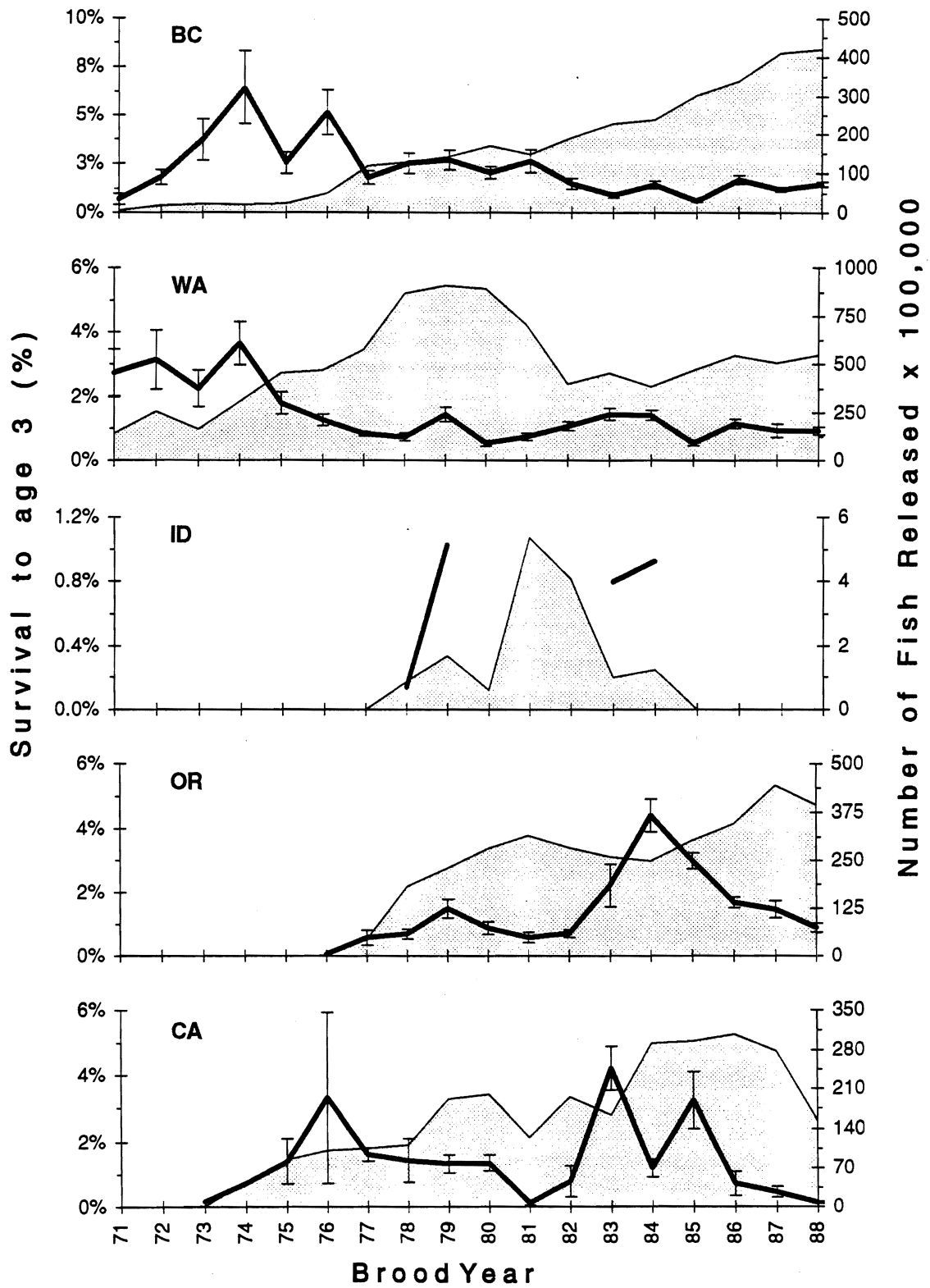

Figure 4. Survival trends for fall chinook salmon. Line represents survival to age 3; error bars are the standard error of the mean; shaded area is number of fish released by brood year x 100,000.

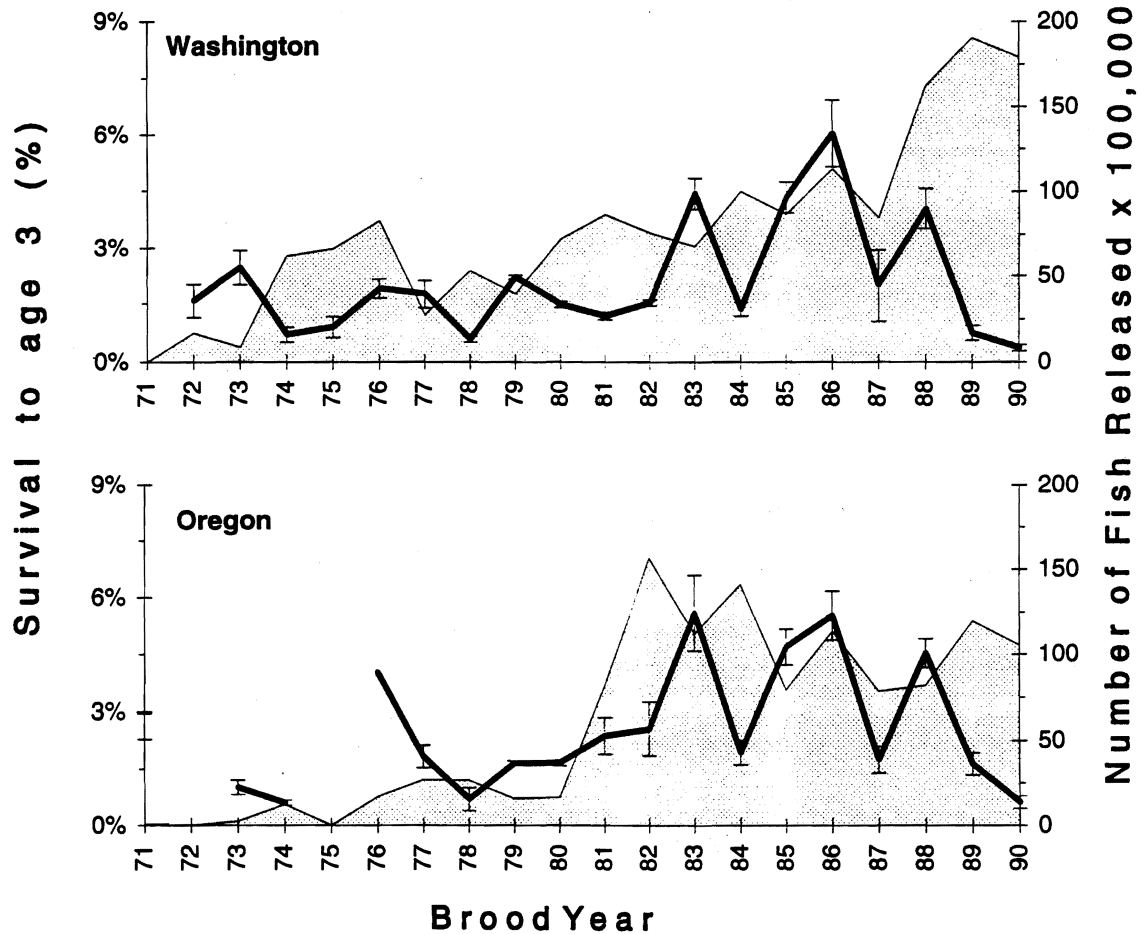

Figure 5. Survival trends for coho salmon in Columbia River hatcheries. Line represents survival to age 3; error bars are the standard error of the mean; shaded area is number of fish released by brood year x 100,000.

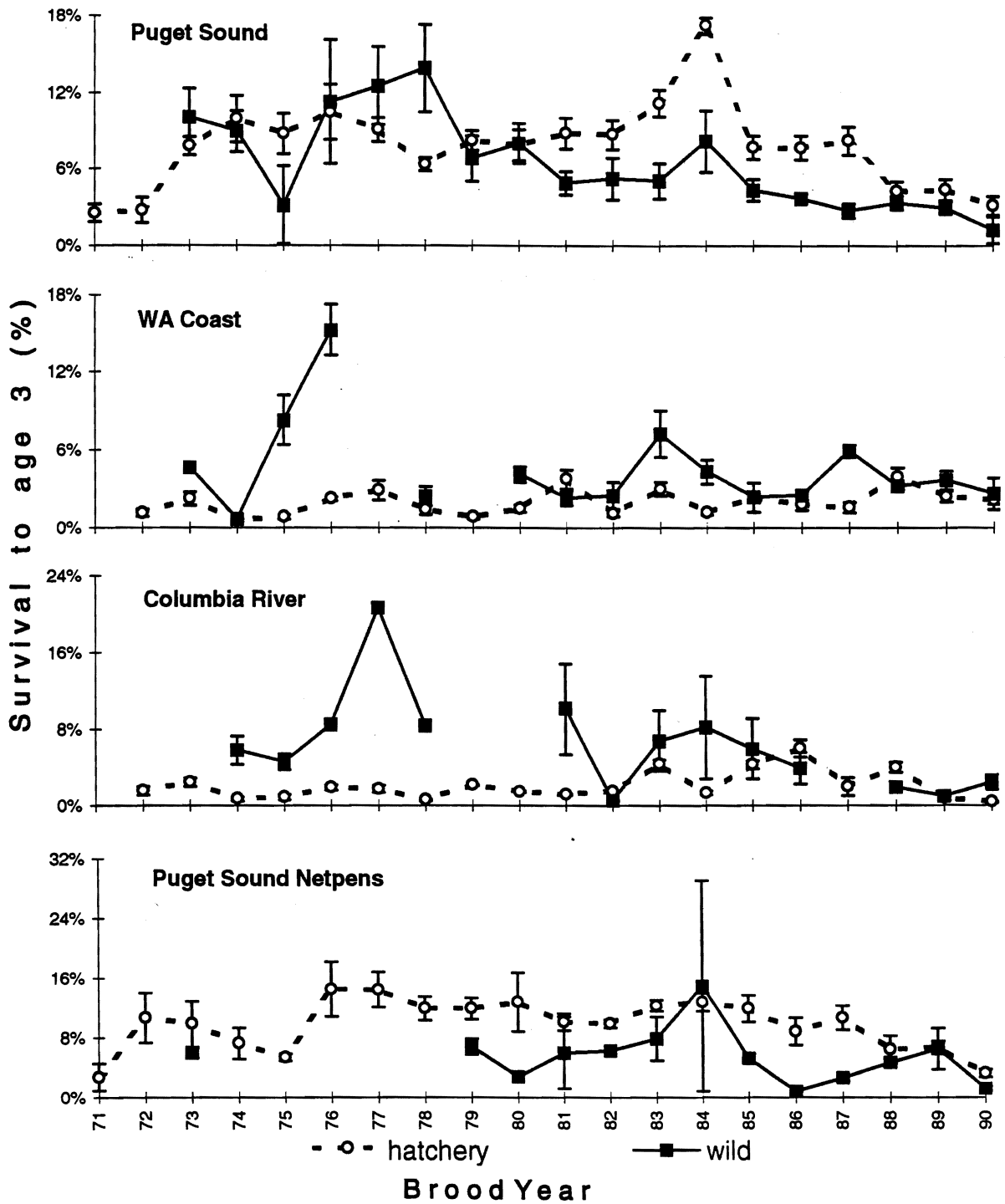

Figure 6. Survival trends of hatchery and wild coho salmon in Washington state. Line represents survival to age 3; error bars indicate standard error of the mean.

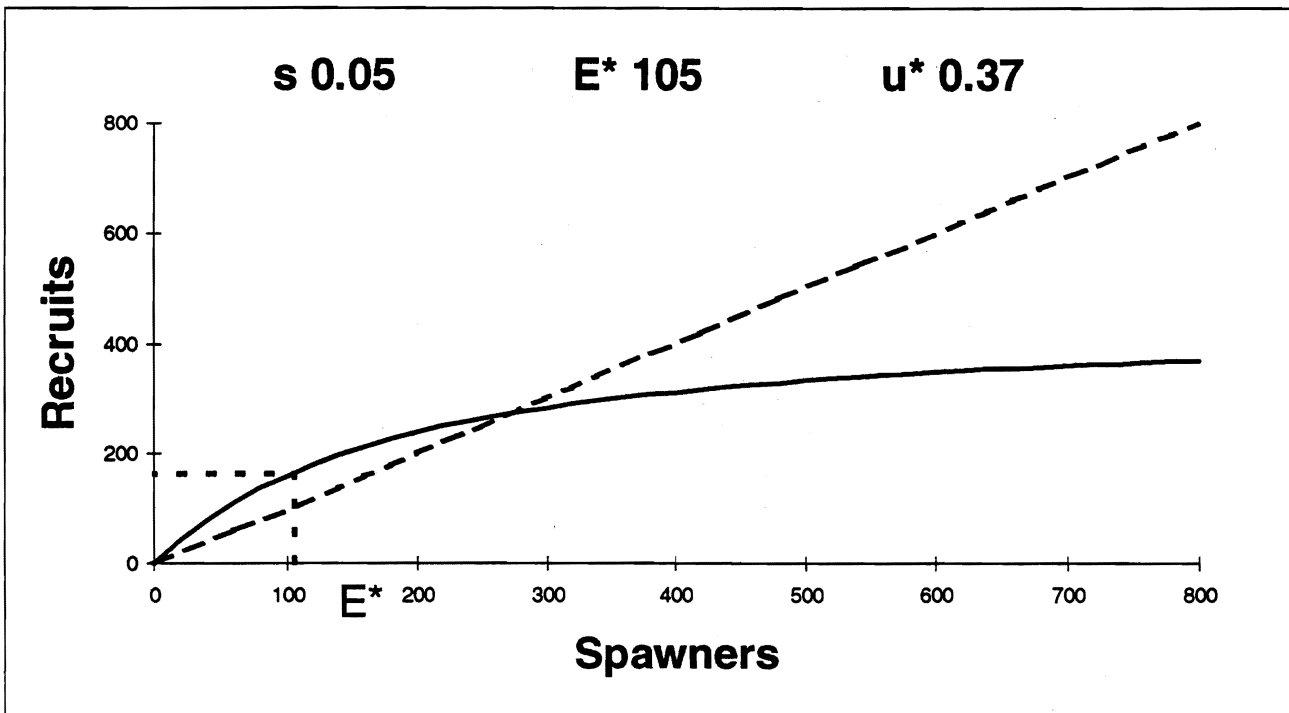
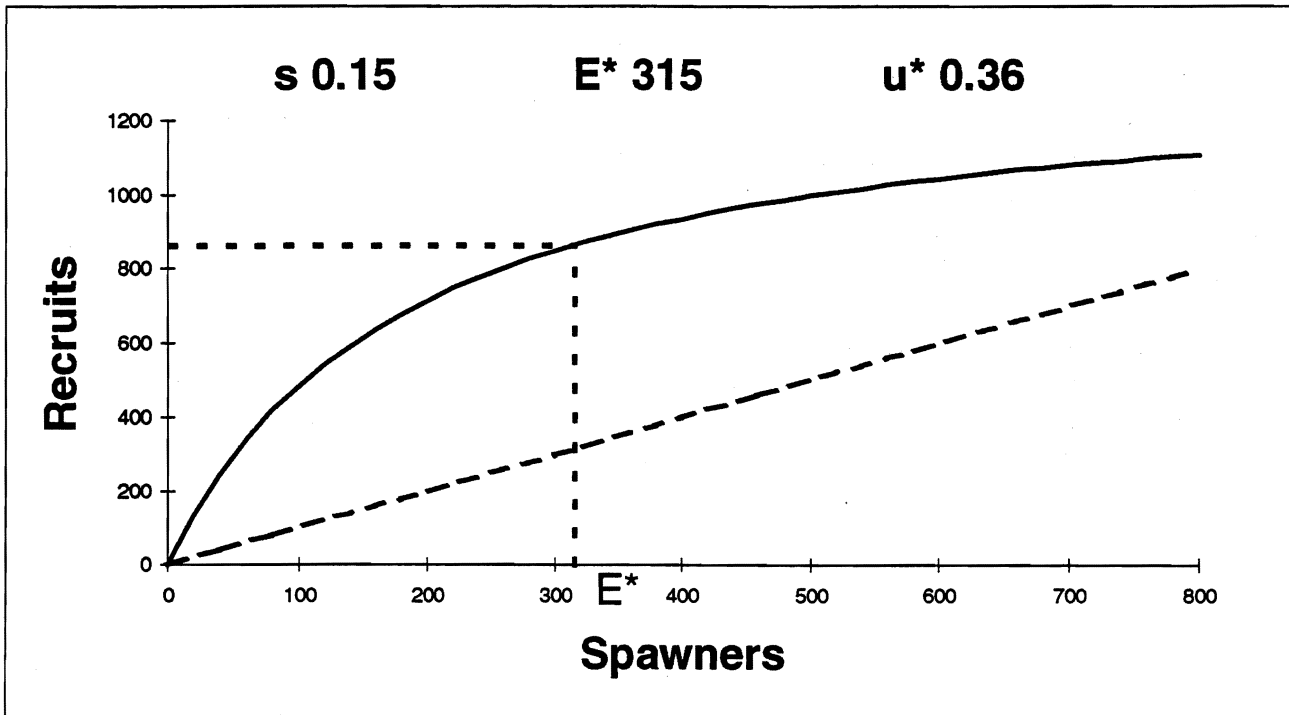

Figure 7. Harvest strategies under different ocean survival rates.

As an example, we have constructed a simple analysis of optimal harvesting for a coho salmon population with constant freshwater conditions, but under two different ocean regimes (Fig. 7). Here we assume that there is a freshwater carrying capacity and a density-independent ocean survival. In case 1, we assume a 15% ocean survival, roughly comparable to the conditions in British Columbia in the early 1970s. The optimal escapement of this hypothetical stock is 315, and the optimal exploitation rate is 63%. The sustainable yield is about 500 fish. If the ocean then turns bad and survival drops to 5% (roughly current survival rates), the sustainable yield drops to 50 fish. The optimum escapement is now only 105, and the optimum harvest rate is 37%.

Thus, while we cannot control the ocean, we must change our management actions as ocean conditions change. We suggest that under present ocean conditions there is little if any sustainable yield for chinook and coho salmon in Oregon, Washington, and British Columbia. Harvest rates need to be drastically reduced, and we should expect the escapements to drop. We might choose to maintain escapements at the old levels, but we should recognize that the reason to do this would be to try to retain a large population size until ocean conditions improve.

Citations

- Coronado, C. 1995. Spatial and temporal factors affecting survival of hatchery-reared chinook, coho and steelhead in the Pacific Northwest . Ph.D. Thesis, University of Washington, Seattle, 235 p.
- Coronado, C., and R. Hilborn. In prep. (a). Spatial and temporal factors affecting survival in coho salmon (*Oncorhynchus kisutch*) in the Pacific Northwest.
- Coronado, C., and R. Hilborn. In prep. (b). Spatial and temporal factors affecting survival in chinook salmon (*Oncorhynchus tshawytscha*) in the Pacific Northwest.
- Hilborn, R., and C. J. Walters. 1992. Quantitative fisheries stock assessment: Choice, dynamics, and uncertainty. Chapman and Hall, New York, 570 p.

PARTITIONING MORTALITY IN PACIFIC SALMON

Michael J. Bradford

Freshwater Habitat Science
Department of Fisheries and Oceans
West Vancouver Laboratory
4160 Marine Dr., West Vancouver, BC
V7V 1N6, Canada

Pacific salmon (*Oncorhynchus* spp.) utilize three or four different habitats during their life: the subsurface of streams and lakes as embryos and larvae, streams and lakes as young juveniles, and estuaries and the ocean as older juveniles. Variability in survival in each of these habitats will contribute to recruitment variation, as will spawner abundance. Here I briefly review the relative roles of each factor in determining adult abundance.

Parent Stock Size

Pacific salmon are relatively unique among nontropical commercial species in that their semelparous life history and often simple age structure results in many spawning populations being dominated by a single cohort of recruits. Thus there is often great variation in spawner abundance from year to year. Further, the low fecundity of salmon compared to many marine fish implies that egg-recruit mortality for salmon is much lower ($M = 6$ to 7 ; Bradford 1995) than for many commercial marine species ($M = 11$ to 14 ; Koslow 1992). Interannual variability in mortality is correlated with the mean (Bradford 1992, Bradford and Cabana 1996), implying that variation in egg-recruit survival in salmon is probably lower than that for marine fish, depending on the strength and timing of density-dependent mortality.

The result of these observations is that there is often a relatively strong relationship between stock and recruitment for Pacific salmon compared to similar data for other species (Fig. 1), and in many cases recruitment can be forecasted from stock sizes with precision not available for marine fish. However, because the harvested stock consists only of recruits, and harvest rates in excess of 70% are common, forecasts of recruitment from stock size are usually not precise enough for modern-day management. Nonetheless, the point I wish to highlight is that in many cases a significant portion of variability in adult returns can be related to parent stock size, irrespective of survival conditions in the various habitats.

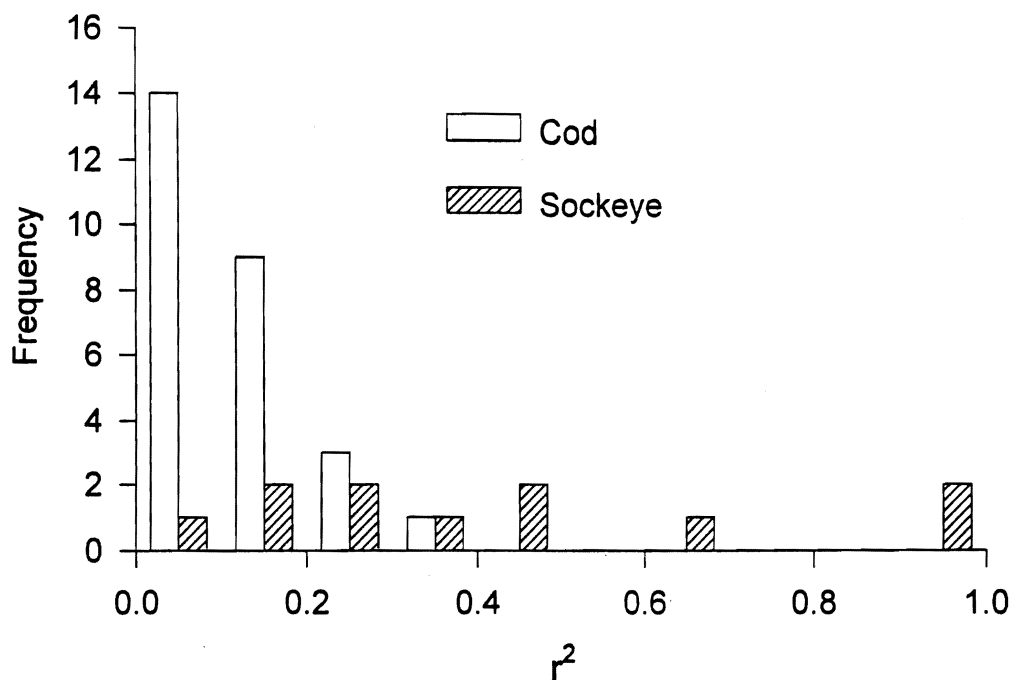

Figure 1. Frequency histogram of the strength of correlation (R^2 shown) between \log_e (recruits) and \log_e (spawners) for 27 cod (*Gadus* spp.) and 11 sockeye salmon populations, showing that the correlation for salmon is generally higher than observed for a marine fish. Very high R^2 values are for populations with extreme variation in abundance among lines.

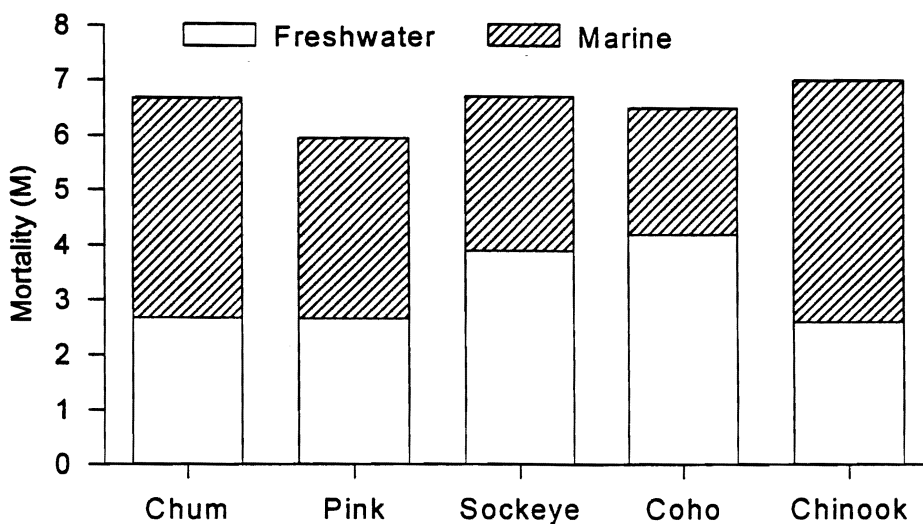

Figure 3. Distribution of mortality ($m = 1 \ln[S]$) among freshwater and marine environments. Data are from a diverse group of populations: shown are averages for each species (Bradford 1995).

Survival in Fresh Water

Salmon use the substrates of rivers and lakes for incubation, and some species use freshwater habitats for rearing. Survival from egg deposition to fry emergence the following spring averages about 10%, although there are some data that suggest survival might be higher for coho (*O. kisutch*) and chinook (*O. tshawytscha*) salmon eggs and alevins (Bradford 1995). The coefficient of variation (CV) for interannual survival is about 30%, averaged over all species. Density effects due to crowding on spawning grounds seem common for species that spawn in dense aggregations (i.e., pink (*O. gorbuscha*), sockeye (*O. nerka*), and chum (*O. keta*) salmon; Foerster 1968).

Coho, sockeye, and some chinook salmon populations spend a year or more in fresh water, and survival rates for this year range from 5% to 25%. In virtually all cases examined, there is strong evidence for density-dependent population regulation in coho salmon (Table 1), probably due to limited amounts of suitable rearing habitat (Bradford et al. in press). Density-dependent survival has also been observed in lake-rearing sockeye salmon juveniles (reviewed by Hume et al. in press). In some cases, the density effects are strong enough to virtually eliminate the effects of parent stock size on smolt abundance, except at very low stock size.

While the roles of interannual variation in the physical environment (i.e., weather, hydrology) and density on survival have been fairly well documented, there are few data sets that allow analysis of decadal changes in freshwater survival due to low-frequency climate change or habitat degradation. One exception is the long series of egg-smolt survival rates for Chilko Lake, B.C. sockeye salmon (Fig. 2). Visual examination of these data suggests an approximately 15-year cycle in survival, although these data have not been quantitatively examined. It is not clear whether the overall downward trend in freshwater survival is real or has resulted from changes in the methods for estimating spawner abundance. Lower survival rates in the most recent years may also be related to record high spawner abundances that occurred in the 1980s (Hume et al. in press).

Marine Survival

Most estimates of marine survival are based on smolt abundances made some distance inland from the sea and, therefore, include mortality during downstream migration and residence in the estuary. The survival of salmon in the ocean ranges from less than 1% to more than 10%, depending on the species, the size at ocean entry, and the length of time spent in the ocean (Bradford 1995). Interannual variability in survival can be quite high (Fig. 2). Although it might be expected that species that enter the ocean at small size are more susceptible to ocean conditions, and have more variable survival rates, the evidence for this is equivocal (Bradford 1995).

Table 1. Density-dependent mortality of juvenile coho salmon. Shown are regression slopes (b) and standard error (SE) for regression of \log_e (smolts) on \log_e (adults) for streams with more than 10 years of data. Slopes significantly less than 1 indicate survival decreases with increasing abundance.

Stream	N	b	SE	P (b = 1)
Snow	15	0.76	0.07	0.01
Black	10	0.54	0.12	0.00
Carnation	20	-0.05	0.16	0.00
Deer	13	0.44	0.15	0.00
Flynn	13	0.26	0.19	0.00
Needle	12	0.33	0.11	0.00
Minter	11	0.15	0.09	0.00

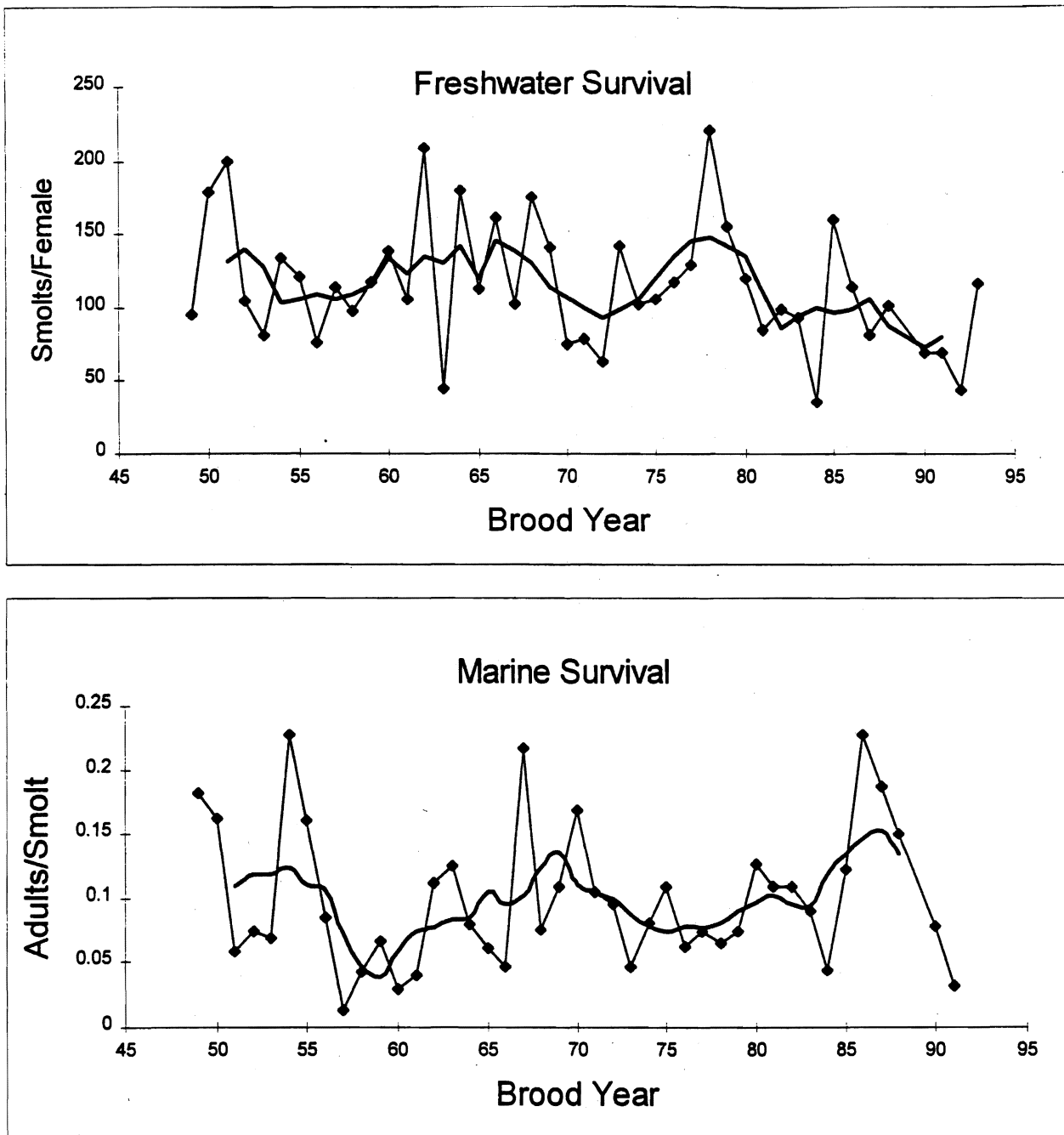

Figure 2. Time series of fresh water (CV = 35%) and marine (CV = 59%) survival rates for Chilkol Lake, BC sockeye salmon. Heavy lines are the 5-year centered running averages.

In contrast to the freshwater environment, the evidence for density-dependent survival in the ocean is not as clear (Pearcy 1992). The analysis of such data is often difficult because of measurement error (Peterman 1982) and time trends in abundance data, hatchery releases, and oceanic conditions. In most analyses, density-dependent effects contribute only a small fraction of the total variability in marine survival rates.

Partitioning Survival

A question that is sometimes posed is what is the relative importance of freshwater, estuarine, or marine habitats for recruitment variation? It is difficult to comment on the role of the estuary on variation in adult abundance due to the technical problems in accurately estimating survival in this habitat, so it is necessary to consider the estuary with the marine environment.

For the other two major habitats, at the species level, empirical analysis indicates mortality is roughly equally divided between the two habitats (Fig. 3), and we expect that the variability in mortality would also be divided similarly (Bradford and Cabana 1996). Available data suggest that this is true (Bradford 1995), and each habitat contributes significantly to recruitment variation, although the exact distribution of mortality among habitats varies by species.

The preceding is based on the naive assumption that mortality in each habitat varies randomly and is independent of events in the other habitat. The sometimes strong density-dependent mortality that occurs in fresh water means that variation in the number of smolts produced by a stream or lake is lower than might be expected based on estimates of the variability in survival or initial egg abundance. In such cases the role of the marine environment in determining recruitment strength will be greater.

Perhaps of greater interest for conservation purposes is determining the relative roles of long-term trends in survival in marine and freshwater habitats. A number of recent analyses have shown decadal trends in adult salmon abundance, which appear to be related to changes in oceanographic conditions that occur at similar scales (e.g., Hare and Francis 1995). Nonetheless, at the moment it is difficult to apportion these trends in abundance to changes in survival in the marine or freshwater environment, or to changes in the number of parent spawners caused by harvest management. The only way to directly address this issue is with long-term data sets where all major stages of the life cycles are accurately enumerated. With these data we may be able to determine the effect that long-term changes in climate have on productivity of both marine and freshwater environments.

Chilko Lake sockeye salmon time series is an example of such data (Fig. 2). From the smoothed trends in freshwater and marine survival rates there might be some evidence for interdecadal cycles in survival. However, the cycles (if real) appear to be out of phase with each other, and there is little correlation in survival between environments. Coupling of

freshwater and marine survival rates may be more likely for coastal stocks (e.g., Cooney et al. 1995).

In summary, partitioning survival to different parts of the salmon's life cycle is somewhat scale dependent. At the annual scale, we can generalize that survival and its variability are roughly equally divided between freshwater and marine habitats. However, there are only a few instances where we can examine the effects of interdecadal-scale climate forcing on freshwater and marine survival simultaneously. Such analyses will be difficult because density-dependent effects and anthropogenic habitat changes in fresh water will tend to obscure climate effects. Nonetheless, these analyses are essential to correctly interpret changes in salmon production at decadal or longer scales.

Citations

- Bradford, M. J. 1992. Strength and precision of recruitment predictions from the early life stages of marine fishes. *Fish. Bull.*, U.S. 90:439-453.
- Bradford, M. J. 1995. Comparative analysis of Pacific salmon survival rates. *Can. J. Fish. Aquat. Sci.* 52:1327-1338.
- Bradford, M. J., G. C. Taylor, and J. A. Allan. In press. Empirical review of coho salmon smolt abundance and the prediction of smolt production at the regional level. *Trans. Am. Fish. Soc.*
- Bradford, M. J., and G. Cabana. 1996. Interannual variation in stage-specific survival rates and the causes of recruitment variation. In R. C. Chambers and E. A. Trippel (editors), *Early life history and recruitment in fish populations*, p. 597-630. Chapman and Hall, New York.
- Cooney, R. T., T. M. Willette, S. Sharr, D. Sharp, and J. Olson. 1995. The effect of climate on North Pacific pink salmon (*Oncorhynchus gorbuscha*) production: Examining some details of a natural experiment. In R. J. Beamish (editor), *Climate change and northern fish populations*, p. 475-482. *Can. Spec. Publ. Fish. Aquat. Sci.* 121.
- Foerster, R. E. 1968. The sockeye salmon. *Bull. Fish. Res. Board Can.* 162.
- Hare, S. R., and R. C. Francis. 1995. Climate change and salmon production in the Northeast Pacific Ocean. In R. J. Beamish (editor), *Climate change and northern fish populations*, p. 357-372. *Can. Spec. Publ. Fish. Aquat. Sci.* 121.
- Hume, J. M. B., K. S. Shortreed, and K. F. Morton. In press. Juvenile sockeye rearing capacity of three lakes in the Fraser River system. *Can. J. Fish. Aquat. Sci.*

- Koslow, J. A. 1992. Fecundity and the stock-recruitment relationship. *Can. J. Fish. Aquat. Sci.* 49:210-217.
- Pearcy, W. G. 1992. *Ocean ecology of North Pacific salmonids*. Univ. Washington Press, Seattle, 179 p.
- Peterman, R. M. 1982. Non-linear relation between smolts and adults in Babine Lake sockeye populations and implications for other salmon populations. *Can. J. Fish. Aquat. Sci.* 39:904-913.

GEOGRAPHICAL VARIATION IN LIFE HISTORIES OF SALMONIDS

Laurie Weitkamp, Peggy Busby, and Kathleen Neely

National Marine Fisheries Service
Northwest Fisheries Science Center
Coastal Zone and Estuarine Studies Division
2725 Montlake Boulevard East
Seattle, WA 98112

Pacific salmonids (*Oncorhynchus* spp.) have complex life histories. They display considerable inter- and intraspecific variability at all life stages, which results from the influence of numerous factors. Despite this variability, geographical patterns in some of the better-studied life stages can provide considerable insight into ecological processes that occur during estuarine and ocean residency, a period for which little is known. This paper describes several examples of how life history trait patterns provide information about key questions concerning estuarine and ocean residence, such as when and why significant mortality occurs, which fish survive, and how widespread particular patterns are. Estuarine and ocean residency is just one part of the life cycle, but considerable insight can be gained by viewing it in the context of the entire life cycle.

A review of data for salmonid populations along the west coast of North America (from numerous sources including Aro and Shepard 1967, Atkinson et al. 1967, Groot and Margolis 1991, Weitkamp et al. 1995) suggests that life history traits largely fall into two categories--those with clear latitudinal and altitudinal trends (e.g., smolt outmigration and spawn timing) and those without apparent trends (e.g., adult size and smolt size). Presumably, traits with strong latitudinal/altitudinal trends are most affected by factors that also have strong latitudinal trends (e.g., temperature, photoperiod), while traits that do not show strong latitudinal trends may be affected by single factors without latitudinal trends or by numerous factors working at smaller geographic scales.

One life history trait that shows a mixed pattern is freshwater age. Two species, pink (*O. gorbuscha*) and chum (*O. keta*) salmon, always leave fresh water shortly after emergence. In contrast, all other species examined (chinook (*O. tshawytscha*), sockeye (*O. nerka*), coho (*O. kisutch*), Atlantic (*Salmo salar*), and masu (*O. masou*) salmon and steelhead (*O. mykiss*) generally have extended (≥ 1 year) freshwater residence and clear latitudinal/altitudinal trends in the duration of the residence.¹

¹ Both ocean-type chinook and sea-type sockeye salmon leave fresh water within their first year, but only after spending several months in fresh water (Healey 1983, Wood 1995).

The difference in patterns of freshwater age (leaving immediately vs. extended residence) suggests the existence of two general juvenile strategies used to make the transition between fresh water and salt water. Possible advantages of the pink/chum (and, to a lesser degree, ocean-type chinook and sea-type sockeye salmon) strategy include avoiding fresh water and its associated problems (such as relatively low average productivity and high mortality and low growth during winter), and taking advantage of highly productive estuarine or nearshore marine habitats, where rapid growth can be achieved to quickly outgrow high levels of size-specific predation. The other strategy (extended freshwater residence) might be driven by low predation levels in freshwater habitats or a longer period of freshwater growth to avoid high predation on small fish in estuarine and marine environments. Because fish using these two strategies enter estuarine and marine waters at dramatically different ages and sizes, they have different requirements from initial estuarine and marine habitats, and mortality patterns are likely to be quite different. Consequently, the results of studies examining populations using one type of strategy may not be relevant to populations using the other strategy.

One example of how knowledge of freshwater residency may provide insight into ocean mortality comes from freshwater age measurements from southeast Alaska populations of coho salmon (Halupka et al. 1993), a species with extended freshwater residence. Freshwater ages in these populations were measured on outmigrating smolts as well as returning adults, allowing a comparison of freshwater age of fish going to sea with those returning from sea. Although freshwater ages measured at these two stages were similar for most populations, two populations were notable exceptions. In both cases, the average freshwater age measured from the smolts was older than the freshwater age measured from the adults, suggesting that ocean mortality within these populations was not random, but rather was higher on the older juveniles. In this example, patterns of life history traits provide insight about which fish do and do not survive, and suggest processes (i.e., low freshwater growth rates) that might have some bearing on marine survival.

Another example of how life history traits provide insight into ocean residence comes from ocean migration patterns for coho salmon as inferred from coded wire tag (CWT) recovery patterns. We compiled marine (as defined in the database) CWT recovery records (PSMFC 1994) for 65 coho salmon hatcheries from southeast Alaska to central California, using recoveries expanded for sampling effort but not for untagged fish (Weitkamp et al. 1995). The proportion of recoveries occurring in each state or province for each hatchery are indicated; CWT recovery patterns are fairly consistent among hatcheries within regions (e.g., British Columbia, Puget Sound and Hood Canal, Columbia River, etc.), but there are abrupt changes between adjacent regions, rather than a gradual transition as might be expected due strictly to the geographic location of the hatcheries (Fig. 1). For example, CWT recovery patterns for coho salmon released from the Naselle Hatchery on Willapa Bay (Washington coast) and from Grays River Hatchery on the lower Columbia River are very different from each other, even though the two hatcheries are separated by less than 20 air miles. Naselle and other Washington coast hatchery coho salmon have much higher recovery rates from British Columbia and Washington and correspondingly lower recovery rates from Oregon and

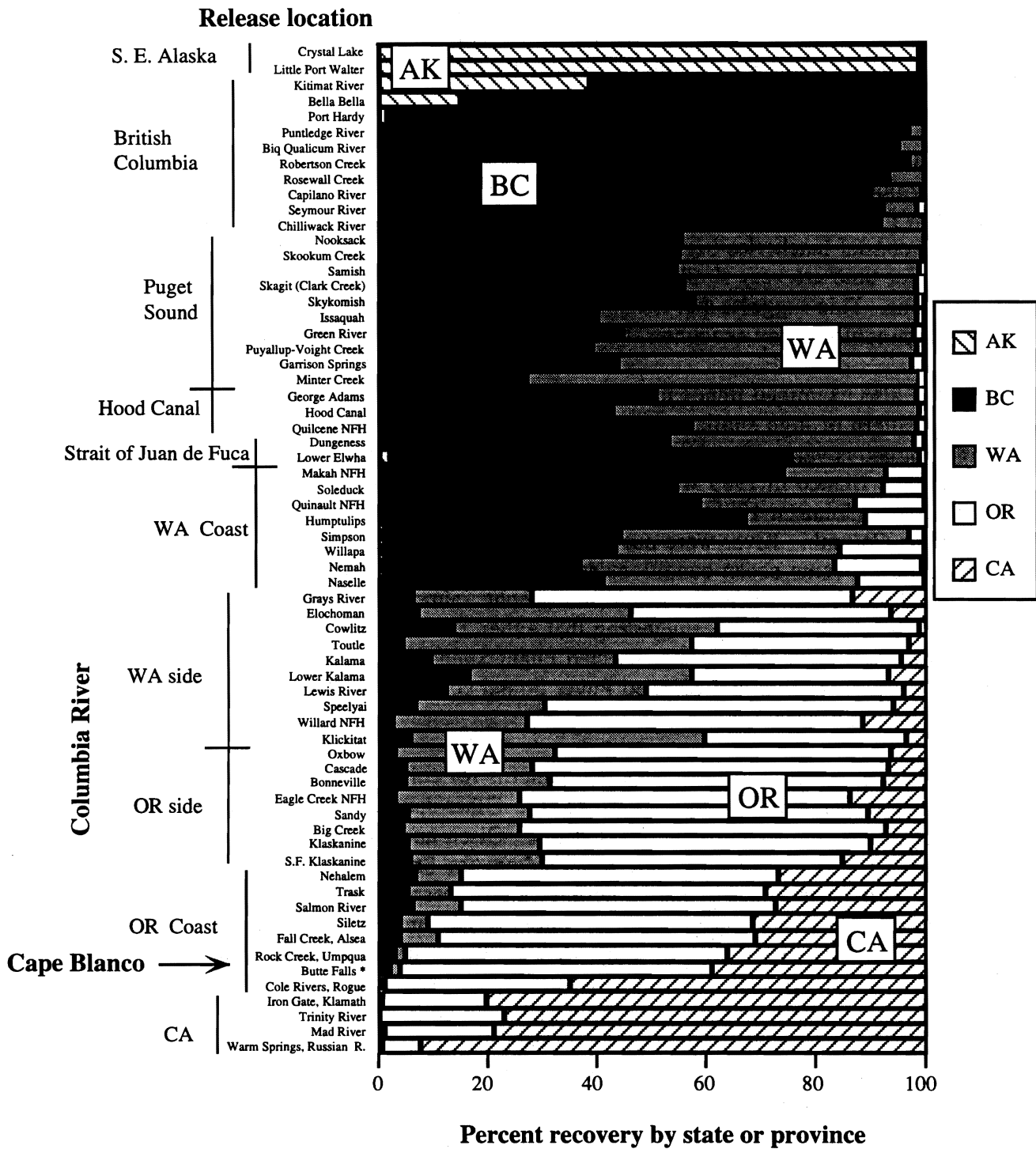

Figure 1. Marine recoveries by state or province of coded-wire-tagged coho salmon released from selected hatcheries in Alaska (AK), British Columbia (BC), Washington (WA), Oregon (OR), and California (CA). *Butte Falls Hatchery is located on the Rogue River but rears Umpqua River coho salmon and releases them into the Umpqua River (PSMFC 1994).

California than do Grays River and other lower Columbia River hatchery fish (Fig. 1). Although these patterns reflect only the last few months of a 1.5-year migration, the dramatic differences in migration patterns suggest that there also may be significant differences earlier in ocean residence as well.

Although patterns of CWT recoveries also vary over time, the responses of stocks within a region are generally strongly correlated. Figure 2 displays the percentage of total marine CWT recoveries from Oregon for fish released from Washington, Oregon, and California coastal hatcheries between 1978 and 1992. Within each of the three regions, patterns over time are very similar across populations, but they are quite different between the three regions. This suggests that fish within each region are responding in similar manner to the ocean conditions they encounter, but that conditions vary significantly between regions.

We also examined trends in coho salmon adult size from different regions and found the same pattern of high similarity within, and large differences between, regions, particularly during anomalous years (Fig. 3). For example, Oregon coast coho salmon returning to rivers north of Cape Blanco in 1983 were exceptionally small, presumably a result of the strong El Niño that year (Johnson 1988). In contrast, coho salmon from rivers south of Cape Blanco or north of the Columbia River were not unusually small in 1983, suggesting they were not experiencing the same ocean conditions as the Oregon coast fish, or, if they were, they were not affected to the same degree. Puget Sound coho salmon were unusually small the following year (1984, Fig. 3), suggesting that either 1) conditions that caused the small size for Oregon coast coho salmon also affected Puget Sound fish, but at an earlier age, or 2) marine conditions moved and affected Puget Sound coho salmon at the same age as the Oregon fish, but 1 year later.

The above discussion indicates that patterns for coho salmon ocean migration and adult size exist at relatively small spatial scales. Other species or populations may show patterns at different spatial scales. For example, Olsen and Richards (1994) compared trends in abundance for stream-type chinook salmon from the Snake River with stream-type Fraser River and ocean-type Puget Sound chinook salmon. Despite the much larger distance by water between the Snake and Fraser River chinook salmon spawning grounds compared to Snake River and Puget Sound spawning grounds, the former pair's abundance trends were very similar ($r = 0.64$), while those for the latter pair were not ($r \leq 0.1$). This suggests that the factors that determine year class strength affected both Snake and Fraser River populations in a similar fashion and were quite different than the factors that determine year class strength for Puget Sound populations. The strength of the Fraser-Snake River correlation, in spite of the presence of eight mainstem dams for the Snake River fish to navigate and none for the Fraser River fish, suggests that ocean conditions play a key role in overall mortality for stream-type chinook salmon in both systems. In this case, geographically distant populations show more similarity than do geographically close populations, which illustrates how life history trait patterns seem particularly useful at indicating how widespread ocean processes and patterns might be.

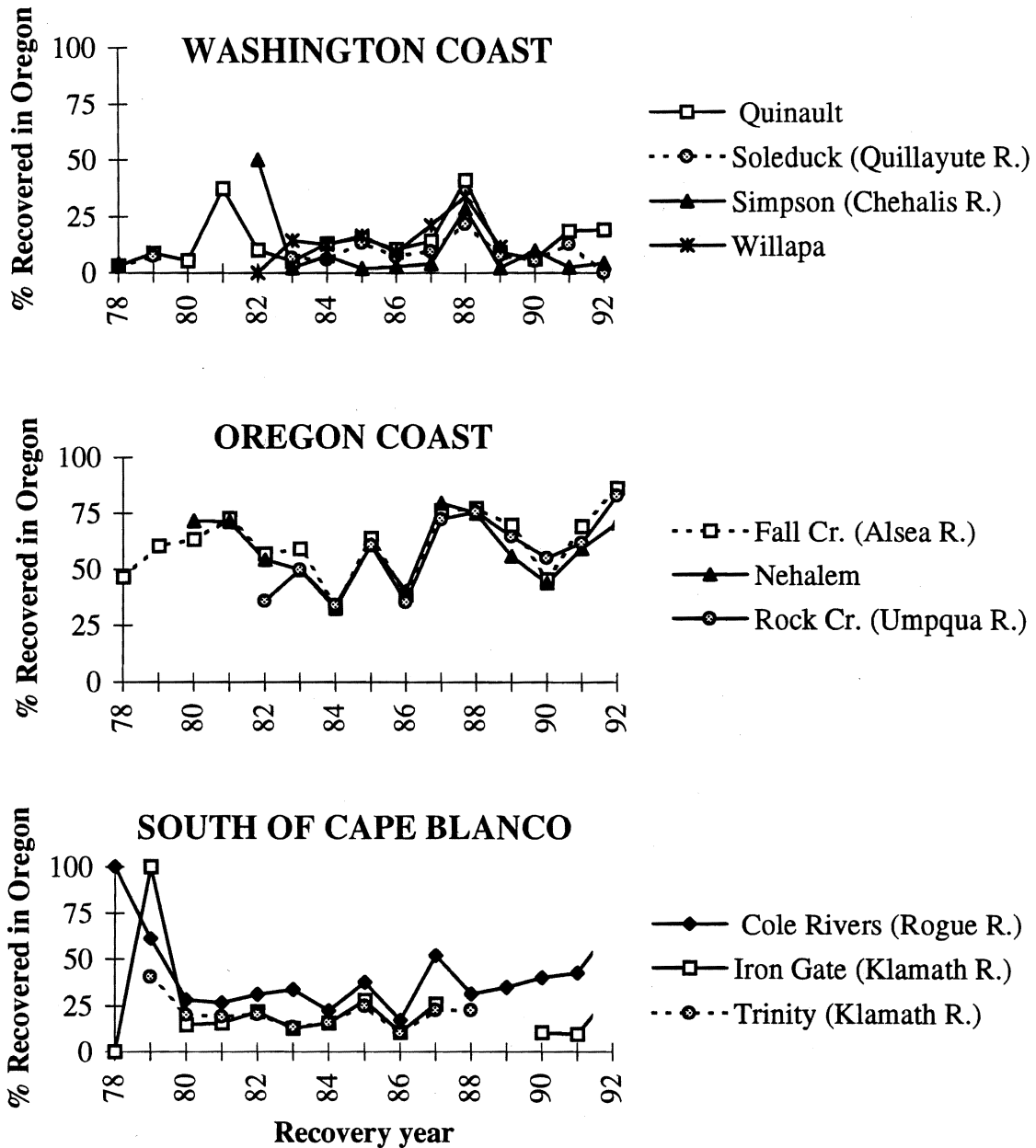

Figure 2. Oregon marine coded-wire tag (CWT) recoveries as a percent of total marine recoveries over time for coho salmon released from Washington, Oregon, and northern California hatcheries, 1978-92.

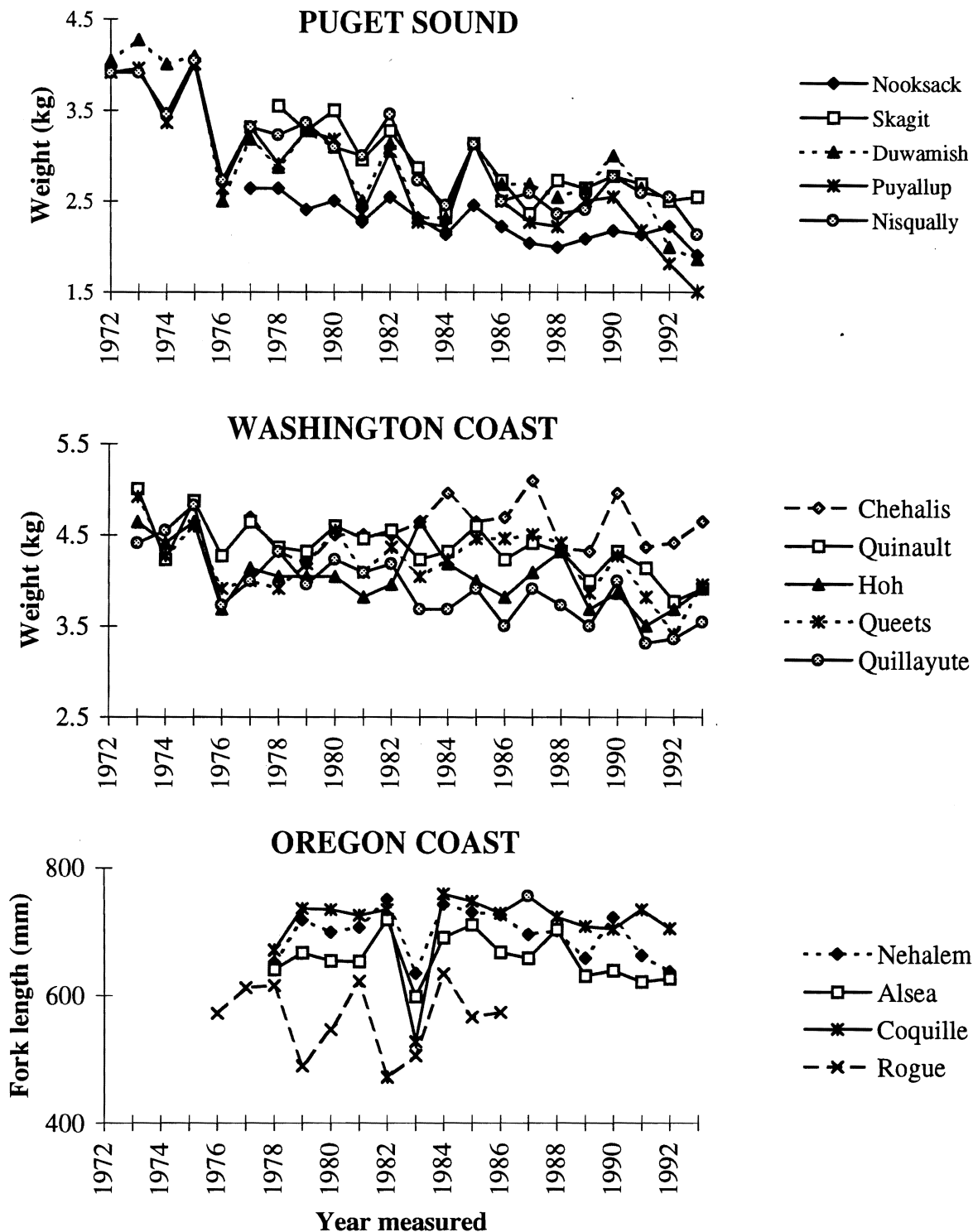

Figure 3. Trends in adult size (weight (kg) of fish caught in in-river fisheries or length (mm fork length) of natural spawners) for coho salmon populations from Puget Sound and along the Washington and Oregon coasts, 1972-93.

A final example of how life history traits provide insight into estuarine and ocean residence comes from the use of jack (precocious male) abundance as a predictor of the following year's adult abundance. Prior to 1983, Oregon coast and Columbia River coho salmon jack (2 years old) abundance was a good predictor of adult (3 years old) abundance (Pearcy 1992). Because jacks only spend 6 months at sea instead of 18 months for adults, this suggested that much of the mortality that determined year-class strength occurred early in the ocean residence. However, since 1983, the relationship between jack and adult abundance has weakened, and jack abundance has been a poor predictor of adult run size in some years. This change in the jack-adult relationship suggests two likely scenarios--either the timing of significant mortality events has changed to later in the ocean residency, perhaps due to low prey abundance, or the proportion of males that become jacks has become more variable, due to large smolt size or poor ocean conditions in some years. Furthermore, Puget Sound coho salmon jack run size has never been a good predictor of adult run size, suggesting a mortality schedule quite different than that for Oregon coast coho salmon prior to 1983. In this example, the relationship between jacks and adults provides information about when large mortality events occur, indicates that these patterns can change over time, and shows how widespread the patterns are.

To summarize, we have provided several examples of how life history trait information provides valuable insight into patterns and processes that occur during estuarine and ocean residency. These examples were the product of a fairly limited review of the subject, and we expect that many more such examples will be unearthed with further investigation. Although ocean residency is just one part of the salmon life cycle, considerable insight about it can be gained by viewing it in the context of the larger life cycle.

Citations

- Aro, K. V., and M. P. Shepard. 1967. Pacific salmon in Canada. *Bull. Int. North Pac. Fish. Comm.* 23:225-327.
- Atkinson, C. E., J. H. Rose, and T. O. Duncan. 1967. Pacific salmon in the United States. *Bull. Int. North Pac. Fish. Comm.* 23:43-224.
- Groot, C., and L. Margolis (editors). 1991. *Pacific salmon life histories*. Univ. British Columbia Press, Vancouver, 564 p.
- Halupka, K. C., J. K. Troyer, M. F. Wilson, and F. H. Everest. 1993. Identification of unique and sensitive coho salmon stocks of southeast Alaska. Draft manuscript, U.S. Dep. Agriculture, Pacific Northwest Research Station, Forest Sciences Laboratory, Juneau, AK, 97 p. (Available from K. Halupka, Biology Dep., Albertson College of Idaho, Caldwell, ID 83605.)

- Healey, M. C. 1983. Coastwide distribution and ocean migrations patterns of stream- and ocean-type chinook salmon, *Oncorhynchus tshawytscha*. Can. Field-Nat. 97:427-433.
- Johnson, S. L. 1988. The effects of the 1983 El Niño on Oregon's coho (*Oncorhynchus kisutch*) and chinook (*O. tshawytscha*) salmon. Fish. Res. 6:105-123.
- Olsen, D., and J. Richards. 1994. Inter-basin comparison study, Columbia River salmon production compared to other West Coast production areas, Phase II analysis. Report to the U.S. Army Corps of Engineers, 80 p. (Available from U.S. Army Corps of Engineers, P.O. Box 2946, Portland, OR 97208-2946.)
- Pacific States Marine Fisheries Commission (PSMFC). 1994. Regional Mark Information System (RMIS) Coded-wire tag on-line database. (Available from Pacific States Marine Fisheries Commission, 45 SE 82nd Dr., Suite 1000, Gladstone, OR 97027.)
- Pearcy, W. G. 1992. Ocean ecology of North Pacific salmonids. Washington Sea Grant Program. Univ. Washington Press, Seattle, 179 p.
- Weitkamp, L. A., T. C. Wainwright, G. J. Bryant, G. B. Milner, D. J. Teel, R. G. Kope, and R. S. Waples. 1995. Status review of coho salmon from Washington, Oregon, and California. U.S. Dep. Commer., NOAA Tech. Memo. NMFS-NWFSC-24, 258 p.
- Wood, C. C. 1995. Life history variation and population structure in sockeye salmon. In J. L. Nielsen (editor), Evolution and the aquatic ecosystem: Defining unique units in population conservation. Am. Fish. Soc. Symposium 17, Bethesda, MD, p. 195-216.

FACTORS INFLUENCING FRESHWATER AND MARINE SURVIVAL OF OREGON'S COASTAL COHO SALMON--WHAT WE KNOW AND WHAT WE DON'T

Steve Johnson

Oregon Department of Fish and Wildlife
Research and Development Section
Newport, OR 97365

In this paper, I review some of the factors that determine freshwater survival of coho salmon (*Oncorhynchus kisutch*) in Oregon coastal streams and discuss ongoing research that is evaluating how the quality of rearing habitat affects survival rates in fresh water. I also review marine survival rates for Oregon coastal coho salmon and discuss an experiment completed in the 1980s to determine if marine survival rates of hatchery reared coho salmon could be increased by releasing them in various locations in the ocean off the Oregon and Washington coasts.

In Oregon and throughout the Pacific Northwest, the freshwater life history of wild coho salmon has been studied extensively (Bustard and Narver 1975a,b; Moring and Lantz 1975; Peterson 1982a,b; Hartman and Brown 1987; Nickelson et al. 1992). Wild coho salmon in Oregon coastal rivers typically spawn in December and January in small tributary streams. Their offspring emerge from the gravels the following spring and rear throughout the summer and winter. In their second spring, the juveniles undergo physiological changes that prepare them for the marine environment. Migration out of the upper tributaries begins in March and April, and most fish enter the ocean by late May. Precocial males (jacks) return to the coastal rivers the same autumn, while adults return after spending a year and a half at sea.

Past studies in the Pacific Northwest suggest average freshwater survival rates (egg to smolt) of 2-3% throughout the region (Marshall and Britton 1990, Bradford 1995). Researchers have long recognized the influence in spawner density on the freshwater survival of coho salmon (Fig. 1). Recent research in Oregon coastal streams indicates the quality of freshwater habitat also influences freshwater survival rates significantly, particularly during the winter rearing period (Fig. 2).

Oregon has completed extensive aquatic habitat inventories in most Oregon coastal watersheds since the late 1980s. We have combined this data set with our understanding of the habitat quality/coho smolt production relationship developed from research streams to estimate freshwater survival potential for many of our coastal river basins. These physical habitat inventories indicate that habitat qualities, and therefore coho salmon freshwater survival rates, vary significantly between watersheds, and are generally lower than previously assumed (T. E. Nickelson, Oreg. Dep. Fish Wildl., 850 SW 15th St., Corvallis, OR 97333, Pers. commun., March 1996).

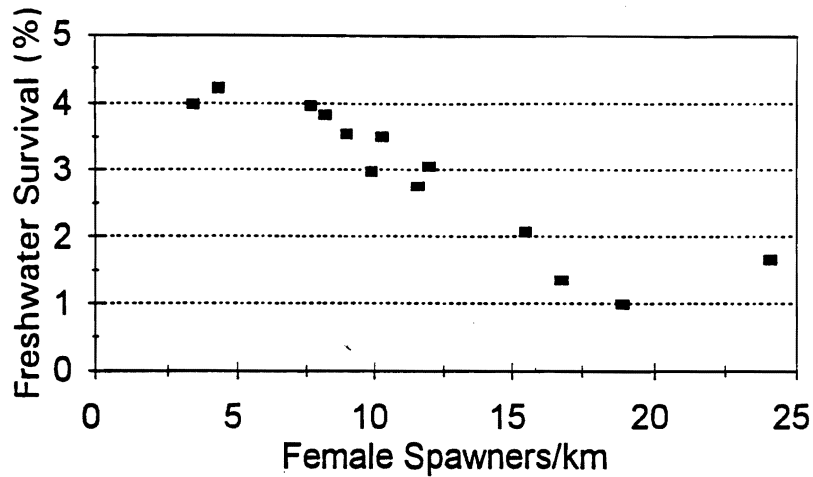

Figure 1. The influence of spawner density on freshwater survival (egg to smolt) of juvenile coho salmon in Deer Creek (Alesia River, Oregon). Data from Chapman (1965).

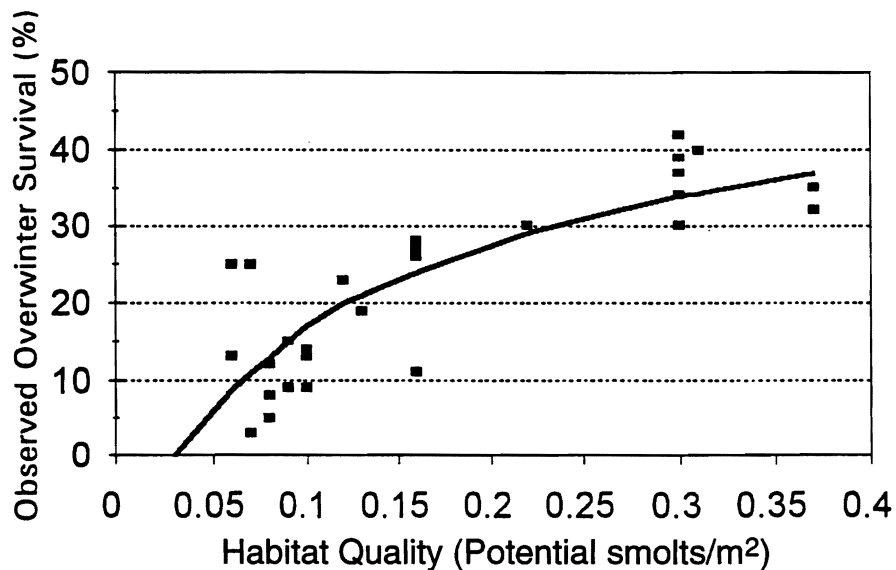

Figure 2. The relationship between juvenile coho salmon over winter survival and habitat quality in Oregon coastal streams. Data from unpublished studies being conducted by the Research Section of the Oregon Department of Fish and Wildlife.

We have few direct measurements of ocean survival for Oregon's wild coho salmon, but ocean survival of coho salmon reared and released from most Oregon coastal hatcheries has dropped significantly during the last decade (Fig. 3) (Nickelson et al. 1994). Oregon coastal hatcheries north of Cape Blanco have averaged only 1.6% ocean survival over the past 10 years. These declines in marine survival have been correlated with various ocean parameters, including upwelling and nearshore temperatures (Fig. 4) (Nickelson 1986, Fisher and Percy 1988). While wild coho salmon stocks in Oregon may be surviving at two or three times the rate of hatchery stocks, some wild stocks will have trouble replacing themselves under present habitat conditions. Recent surveys of spawning adult coho salmon indicate that this is indeed the case for some Oregon coastal basins.

Ocean conditions appear to have negatively affected coho salmon survival of most Oregon coastal coho salmon stocks, particularly north of Cape Blanco. However, data from adult spawning surveys completed every winter on Oregon's central coast suggest that estuaries may also sometimes play an important role in determining adult survival. In the past 2 years, we have observed significant differences in the number of recruits per spawner in three central coast river basins (Siletz, Yaquina, and Alsea Rivers). The 1991 and 1992 broods from the Yaquina River showed a significant increase in spawners compared to the number of parental spawners (apparently in response to a substantial decrease in ocean harvest rate during 1994 and 1995). The Siletz and the Alsea Rivers (located approximately 30 km to the north and 18 km to the south of the Yaquina River, respectively) showed no improvement in adult returns for the 1991 and 1992 broods (Fig. 5). Such different return rates from river basins in such close geographic proximity suggest factors other than offshore ocean conditions may be influencing smolt survival. Differential smolt survival within estuaries would certainly produce the results recently observed in these three river basins and needs to be considered as an additional factor that may play an important role in adult production of Oregon's wild coho salmon stocks.

To determine if marine survival could be influenced by release location in the marine environment, experimental groups of hatchery reared coho salmon smolts were released into the lower Columbia River (below Bonneville Dam at Rkm 234), the Columbia River estuary, and four marine locations off the mouth of the Columbia River from 1983 to 1987 (Solazzi et al. 1991). We chose release sites based on different oceanic features associated with the mouth of the Columbia River and its discharge into the Pacific Ocean. The marine release locations included 1) the mouth of the Columbia River, 2) the Columbia River plume water, 3) coastal water approximately 19 km north and 19 km offshore of the mouth of the river, and 4) oceanic water approximately 38 km offshore. Coho salmon smolts released at the upper end of saltwater intrusion into the Columbia River (Rkm 29) survived at significantly higher rates than fish released in fresh water below Bonneville Dam (Rkm 234). The coho salmon smolts released directly into the ocean at the four marine release sites did not survive at rates significantly different from those of the control groups released in fresh water near Bonneville Dam, and they yielded few clues to the location or source of most of the marine mortality. All groups showed interannual variation. Groups released in 1983 showed the poorest survival, resulting from the high ocean temperatures associated with the El Niño event that

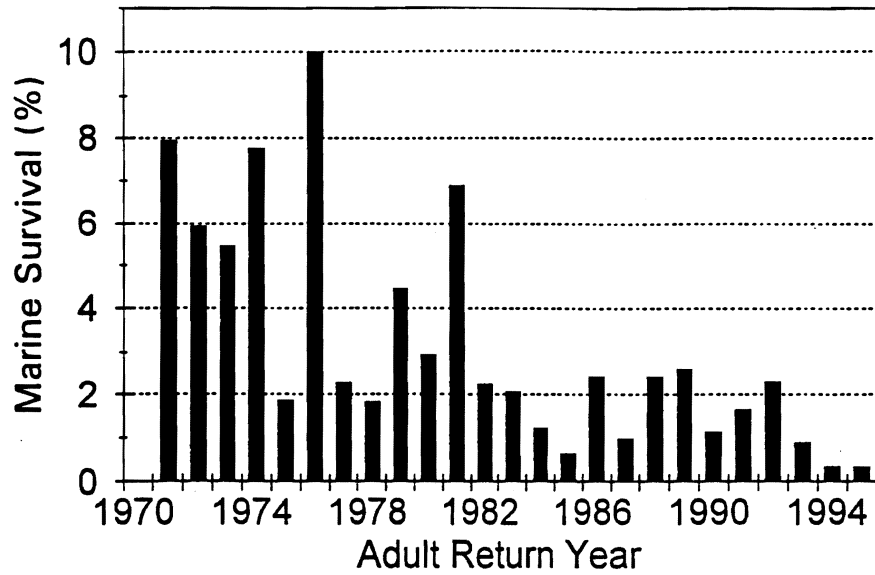

Figure 3. Marine survival of coho salmon smolts released from Fall Creek Hatchery (Alsea River, Oregon), 1970-94.

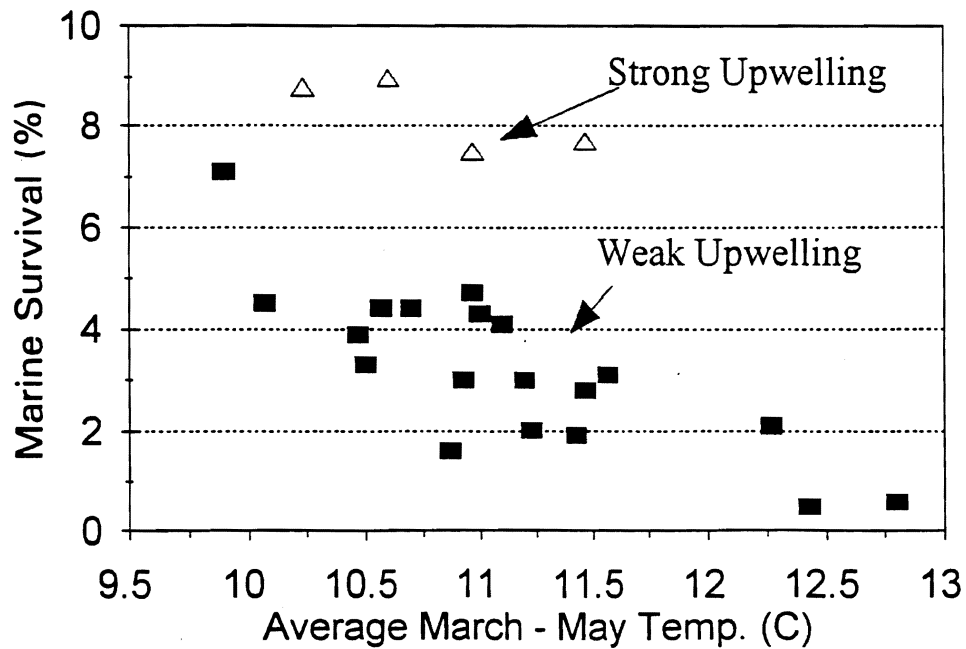

Figure 4. The influence of ocean temperature and coastal upwelling on marine survival of coho salmon released from Oregon hatcheries.

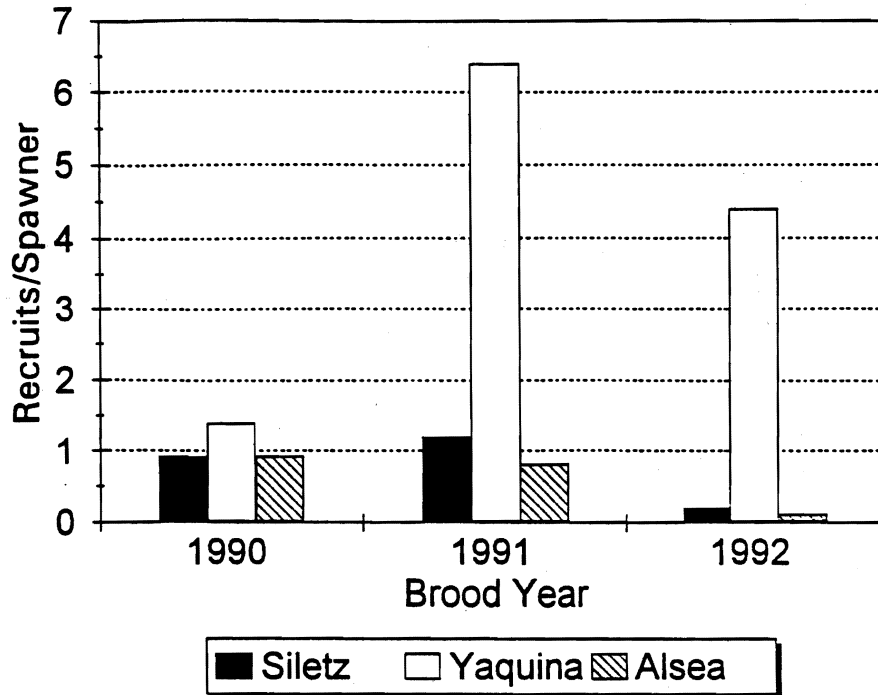

Figure 5. The recruits/spawner of coho salmon returning to three rivers on the central coast of Oregon. Data from yearly spawning surveys conducted by the Oregon Department of Fish and Wildlife.

year (Johnson 1988). Groups released in 1985 experienced the lowest ocean temperatures during the spring, and all groups survived at their highest rate that year (Table 1).

Citations

- Bradford, M. J. 1995. Comparison of Pacific salmon survival rates. *Can. J. Fish. Aquat. Sci.* 52:1327-1338.
- Bustard, D. R., and D. W. Narver. 1975a. Aspects of the winter ecology of juvenile coho salmon (*Oncorhynchus kisutch*) and steelhead trout (*Salmo gairdneri*). *J. Fish. Res. Board Can.* 32:667-680.
- Bustard, D. R., and D. W. Narver. 1975b. Preferences of juvenile coho salmon (*Oncorhynchus kisutch*) and cutthroat trout (*Salmo clarki*) relative to simulated alteration of winter habitat. *J. Fish. Res. Board Can.* 32:681-687.
- Chapman, D. W. 1965. Net production of juvenile coho salmon in three Oregon streams. *Trans. Am. Fish. Soc.* 94:40-52.
- Fisher, J. P., and W. G. Percy. 1988. Growth of juvenile coho salmon (*Oncorhynchus kisutch*) in the ocean off Oregon and Washington, USA, in years of different coastal upwelling. *Can. J. Fish. Aquat. Sci.* 45:1036-1044.
- Hartman, G. F., and T. G. Brown. 1987. Use of small, temporary, floodplain tributaries by juvenile salmonids in a west coast rain-forest drainage basin, Carnation Creek, British Columbia. *Can. J. Fish. Aquat. Sci.* 44:262-270.
- Johnson, S. L. 1988. The effect of the 1983 El Niño on Oregon's coho (*Oncorhynchus kisutch*) and chinook (*O. tshawytscha*) salmon. *Fish. Res. (Amst.)* 6:105-123.
- Marshall, D. E., and E. W. Britton. 1990. Carrying capacity of coho salmon streams. *Can. Manuscript Rep. Fish. Aquat. Sci.* 2058:1-32.
- Moring, J. R., and R. L. Lantz. 1975. The Alsea watershed study; effects of logging three headwater streams of the Alsea River, Oregon, Part I. Biological studies. *Oreg. Dep. Fish Wildl. Res. Rep.* 9:1-39.
- Nickelson, T. E. 1986. Influences of upwelling, ocean temperature, and smolt abundance on marine survival of coho salmon (*Oncorhynchus kisutch*) in the Oregon production area. *Can. J. Fish. Aquat. Sci.* 43:527-535.
- Nickelson, T. E., J. Nicholas, H. Weeks, and K. Kostow. 1994. Oregon coho salmon biological status assessment. *Oreg. Dep. Fish Wildl., Corvallis, OR*, 59 p.

Table 1. The number of adult coho salmon caught in ocean fisheries that were originally released as smolts from various locations in the ocean, the Columbia River estuary, and in the Columbia River 234 km upstream. The number of adult returns has been adjusted to reflect a 40,000 smolt release for each group. See Solazzi et al. (1991) for additional information.

Year of release	Ocean catch by release location					
	Fresh water	Estuary	Bar	Plume	North of plume	38 km
1983	53	67	18	81	132	74
1984	350	380	257	433	241	196
1985	651	1219	820	929	1375	776
1986	541	814	626	489	483	154
1987	317	597	195	248	177	142

- Nickelson, T. E., J. D. Rodgers, S. L. Johnson, and M. F. Solazzi. 1992. Seasonal changes in habitat use by juvenile coho salmon (*Oncorhynchus kisutch*) in Oregon coastal streams. *Can. J. Fish. Aquat. Sci.* 49:783-789.
- Peterson, N. P. 1982a. Population characteristics of juvenile coho salmon (*Oncorhynchus kisutch*) overwintering in riverine ponds. *Can. J. Fish. Aquat. Sci.* 39:1303-1307.
- Peterson, N. P. 1982b. Immigration of juvenile coho salmon (*Oncorhynchus kisutch*) into riverine ponds. *Can. J. Fish. Aquat. Sci.* 39:1308-1310.
- Solazzi, M. F., T. E. Nickelson, and S. L. Johnson. 1991. Survival, contribution, and return of hatchery coho salmon (*Oncorhynchus kisutch*) released into freshwater, estuarine, and marine environments. *Can. J. Fish. Aquat. Sci.* 48:248-253.

DECADAL SCALE CLIMATE PATTERN AND SALMON SURVIVAL
INDICATORS, INTERACTIONS, AND IMPLICATIONS

James J. Anderson

School of Fisheries
Box 358218
University of Washington
Seattle WA 98195-7980

Over this century, management strategies have been unsuccessful in halting the salmon decline in the Columbia River system. Through the failures, an understanding of the processes affecting the fishery has evolved an ecosystem perspective in which both anthropogenic and natural factors are considered. In this paper, I illustrate how this history has evolved using a stock-recruitment model that represents the assumptions and projections through three management periods, each one an adaptive management experiment with unique problems and a management paradigm. In recent years, this cycle has been coined adaptive management, where learning is achieved through management actions (Lee 1993).

Adaptive management involves a number of basic steps outlined in Figure 1. An action taken on a resource is based on a prior prediction of its effect. The actual effect is monitored, either by exploitation of the resource or through a specific monitoring program, and the results are evaluated through comparison with the prior prediction. Discrepancies between the predicted and observed effects are used to modify the management paradigm and develop new actions and predictions.

Model

To illustrate how the management paradigm can change between experiments, consider a Ricker-type stock-recruitment model that contains mortality associated with hydrosystem passage, harvest, habitat loss, and changes in ocean/climate conditions. The model assumes a generic chinook salmon (*Oncorhynchus tshawytscha*) stock with a fixed maturation at age 4. For each cohort, the model first removes harvest; second, generates recruits, and third, updates the population. The algorithm is

$$\begin{aligned} S_i &= S_{preharvest_i} - harvest_i * S_{preharvest_i} \\ R_i &= f * habitat_i * S_i * \exp(-passage_i - climate_i - b * S_i) \\ S_{preharvest}(i + 1) &= S_i + R_i \end{aligned}$$

where for generation i , $S_{preharvest_i}$ is the harvestable population, S_i is the population with harvest removed, R_i is recruitment, $habitat_i$ is a measure of spawning habitat, f is egg production per adult, $passage_i$ is hydrosystem mortality, $climate_i$ is mortality attributed to climate-induced changes in survival, b is a density dependent mortality rate, and $harvest_i$ is

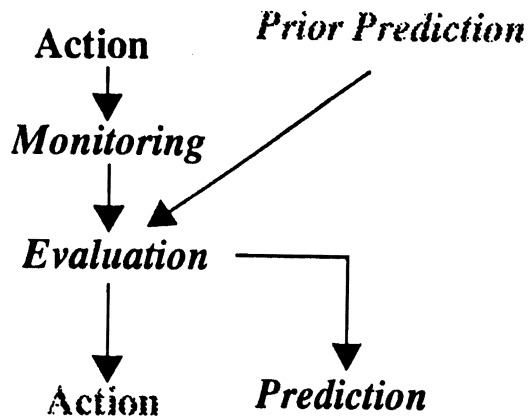

Figure 1. Steps in an adaptive management experiment.

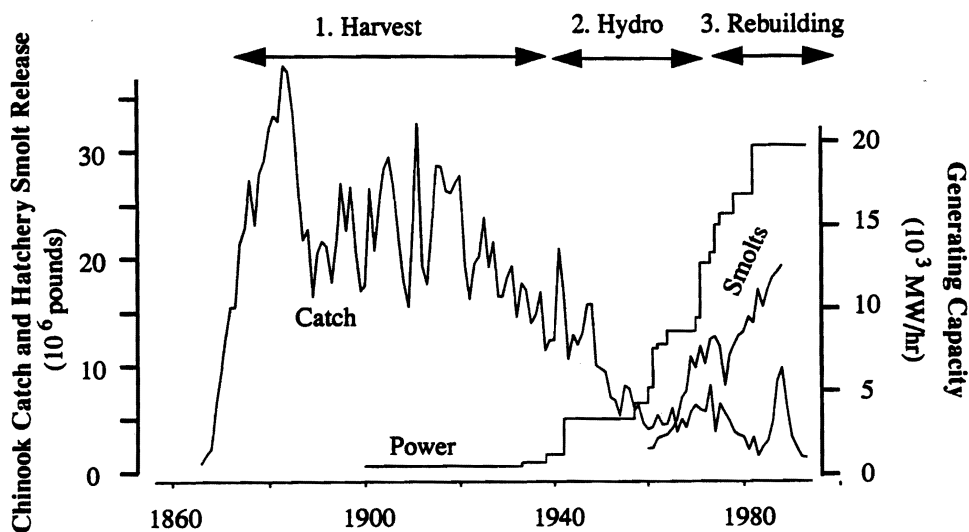

Figure 2. The history of the Columbia River has three major adaptive management experiments: harvest, hydrosystem development, and fishery rebuilding.

the harvest rate. These factors are set to represent the beliefs during each management period or experiment. Factors not accounted for in an experiment are held constant.

Important trends in the Columbia River history, representing basic paradigm shifts, fall into three adaptive management experiments: 1) harvest experiment (1866-1932), 2) hydro development experiment (1932-75), and 3) fishery rebuilding experiment (1975-95). The periods are illustrated with chinook salmon harvest, hydro development, and hatchery output in Figure 2.

Adaptive Management Experiments

The harvest experiment began with the Columbia River commercial fisheries (1860) and ended with the construction of the first mainstem dam (1932). The industry quickly expanded and stabilized between 1890 and 1920. In addition to harvest, salmon production was affected by a cumulative loss of habitat due to farming, grazing, timber harvest, irrigation, and mining (Lichatowich and Mobrand 1995). These losses were largely ignored and unregulated. Ocean and climate effects were unknown.

During the harvest experiment, managers assumed that overharvest was the major reason for the catch decline and the solution was to regulate fishing. The stock recruitment model illustrates that, assuming all other factors were constant, harvest reductions should have stabilized the fishery (Fig. 3). Since catch was relatively stable between 1890 and 1920, there was no compelling reason to believe that limited harvest restrictions were not effective. The decline accelerated after 1920, which motivated the banning of stationary fishing gear in 1934.

A hydrosystem development experiment followed between 1932 and 1975 when 19 major dams were built on the Columbia and Snake Rivers and many more were built in the tributaries. It was clear that the dams destroyed spawning habitat and degraded river passage. To deal with adult upstream passage, fish ladders were installed on the mainstem dams below Chief Joseph and Hells Canyon Dams, but the problem of juvenile downstream passage was not addressed. To replace lost habitat, hatcheries were constructed; by 1975 the biomass of hatchery smolts released into the Columbia River Basin equaled the adult catch (5 million pounds) (Fig. 2). Expressing these assumptions in the model, catch would have increased by about 1950, and a significant reduction in the harvest rate would not be required (Fig. 4).

Mitigation through hatcheries and fish ladders was unsuccessful, so a third cycle of adaptive management, the stock rebuilding experiment, commenced with a program including monitoring, evaluation, and models. The focus was in four areas: harvest, habitat, passage, and fish production. In particular, smolt migration was identified as a problem and actions were taken to improve downstream passage survival. These included a water budget to speed smolt migration, juvenile bypass facilities and spill to divert smolts from turbines, and a program to collect and transport Snake River smolts to below Bonneville Dam. In addition,

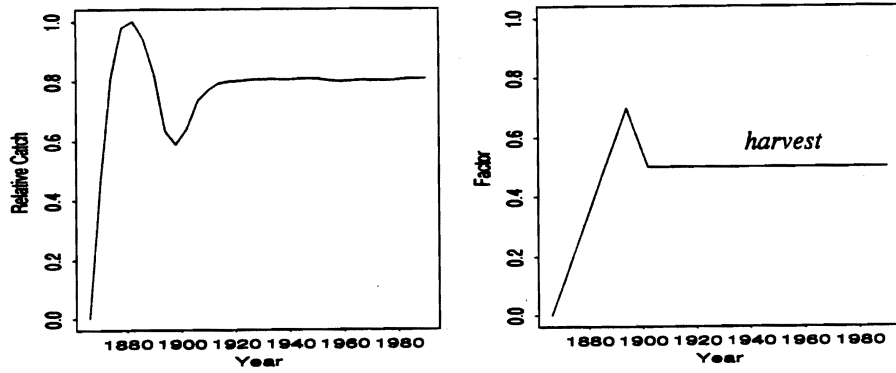

Figure 3. The harvest experiment strategy was to limit harvest rate.

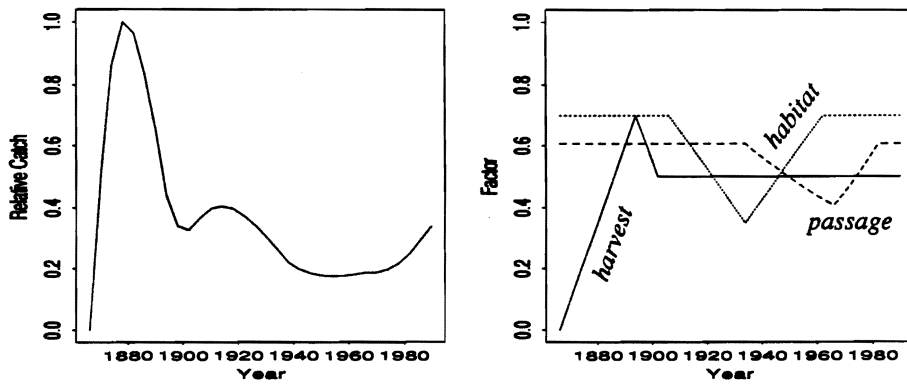

Figure 4. Management actions in the hydro development experiment included adult passage ladders and replacing lost habitat with hatcheries.

since gains made in smolt passage could be lost in harvest, additional fishing regulations were implemented. With the rebuilding program assumptions represented in Figure 5, the stock decline should have been halted in the 1980s.

These management actions did not stop the decline which has again brought managers to question the underlying assumptions on which the actions were based. As a result, the research/management community is moving into a fourth adaptive management experiment, the focus of which is to understand the fisheries through an ecosystem approach. In particular, the new focus examines the effect of decadal scale climatic and oceanic variation on fish survival. Earlier management paradigms ignored this factor.

To represent the effect of climate and ocean conditions, consider the Pacific Northwest Index (PNI), which consists of air temperature, rainfall, and snowpack data from the Northwest (Ebbesmeyer and Strickland 1995). The PNI pattern is similar to other climate indicators which show relationships to fish abundance and catch over the North Pacific (Beamish 1995). Of particular importance, all the climate indicators have a pronounced shift in 1976-77 when the North Pacific changed from a cool regime to a warm regime. The cool regime was favorable to West Coast salmon stocks and the warm regime was favorable to Alaskan stocks.

To illustrate the potential impact of climate, the stock recruitment model assumes the PNI is directly related to the salmon ocean survival rate (Fig. 6). During hydrosystem development the PNI was high, while during the stock rebuilding phase the PNI was low. If ocean survival followed the same trend, the negative impact of the hydrosystem during its development would be masked by the concomitant favorable ocean conditions. Also, the large replacement of lost habitat with hatcheries postulated in earlier management experiments (Figs. 4-5) is not required. Otherwise the stocks would have significantly increased during the rebuilding experiment.

The 1975-76 ocean regime shift, producing unfavorable conditions for fish, complicates the interpretation of the effectiveness of hatchery actions. Coronado-Hernandez (1995), in an analysis of salmonid hatchery survivals from the West Coast and Alaska, concluded that ocean conditions were partially responsible for the decline in hatchery productivity while disease and genetic changes were not significant factors. Previously, declining hatchery productivity was generally attributed to such factors.

The ocean regime shift also complicates the interpretation of efforts to improve smolt passage after 1976. Of particular importance is the transportation program. One hypothesis, which ignores the ocean effect, attributes the Snake River wild chinook salmon decline to fish transportation. The evidence offered is a correspondence in the decline of survival expressed as a smolt-to-adult ratio (SAR) (U.S. Department of Commerce 1995) to the percent of Snake River fish that were transported. Figure 7 suggests that survival went down when transportation increased.

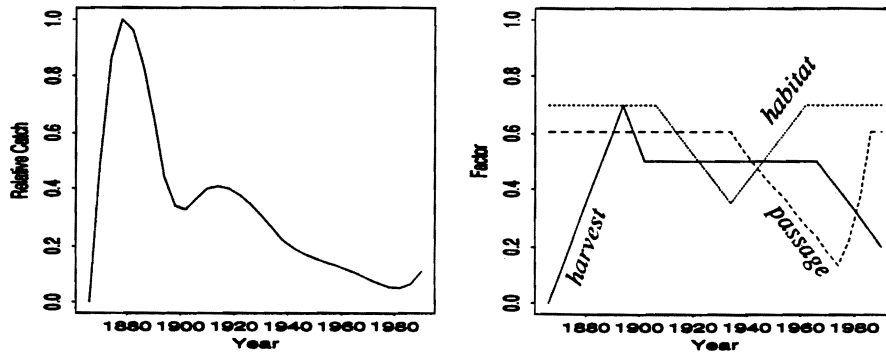

Figure 5. The fishery rebuilding experiment involved new actions including harvest restrictions and improved juvenile passage. The model indicates the stock would improve beginning about 1980.

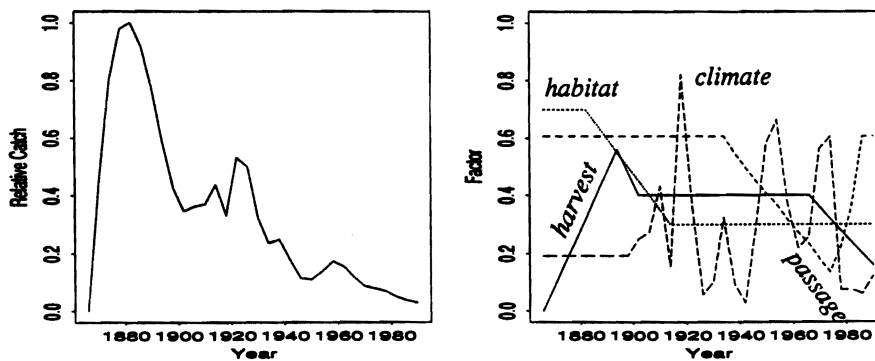

Figure 6. The ecosystem adaptive management experiment includes climate factors and downgrading of the effectiveness of habitat actions.

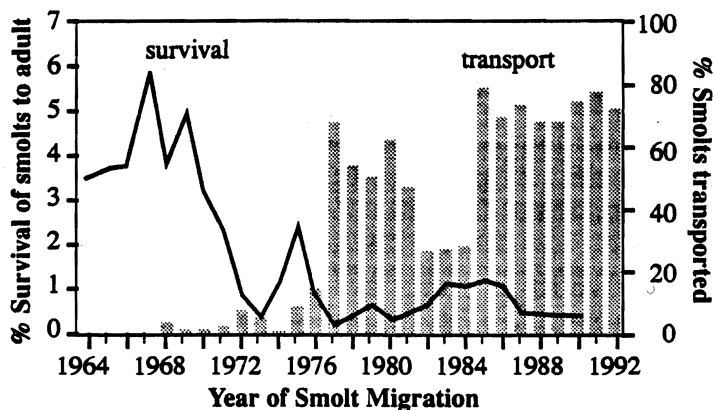

Figure 7. Snake River spring chinook salmon smolt-to-adult survival and percent of the run transported.

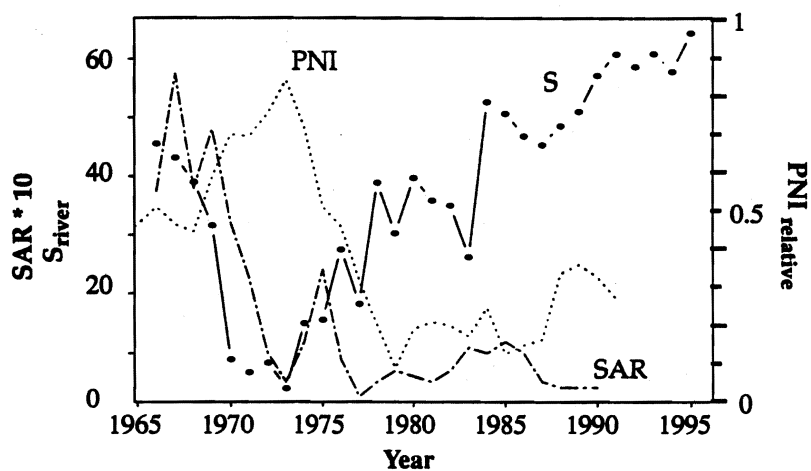

Figure 8. Pacific Northwest Index (PNI) climate indicator and juvenile passage survival estimate (S) move in opposite directions and result in declining smolt-to-adult survival (SAR).

An alternative hypothesis assumes that in-river survival has improved and fish transportation has been effective (survival of transported fish greater than 80%), but passage survival improvements were negated by poor ocean conditions. This hypothesis is supported by studies indicating high smolt survival through the Snake River (Muir et al. 1996), and estimates generated from the CRiSP1.5 mainstem passage model (Anderson et al. 1996), which show improving smolt passage survival since the early 1970s. The improvement is attributed to reduced gas bubble disease, improved dam operations (Williams and Matthews 1995), and the transportation program which was initiated in 1977. The contention that climate change negated passage improvements is supported in Figure 8 which shows a negative correlation between the PNI climate index and CRiSP estimated in-river survival between 1966 and 1990. Furthermore, prior to 1975, the smolt-to-adult survival followed the CRiSP in-river survival pattern, suggesting that the poor passage conditions during the construction of the lower Snake River dams was a significant factor in lowering smolt-to-adult survival between 1966 and 1975. After 1975, the SAR followed the PNI, which switched to the regime unfavorable to West Coast salmon. This suggests that poor ocean survival was a major contributor to the low SAR after 1975.

Conclusions

Climate clearly has had an impact on the decline of Columbia River salmon and compels a reinterpretation of the anthropogenic impacts, principally harvest and the hydrosystem. The significance of climate is suggested in the patterns of the PNI, the hydrosystem generating capacity, and Columbia River chinook salmon catch (Fig. 9). Three features are noteworthy: 1) the catch decline in 1920 corresponds with PNI change from a cool/wet regime to a warm/dry regime; 2) hydrosystem development, starting in the 1940s, was concomitant with the PNI switching back to the cool/wet regime; 3) the stock rebuilding effort, beginning in 1976, occurred with the PNI returning to the warm/dry regime.

The start of the catch decline in 1920 is possibly the result of a change in climate conditions and an inability of the harvest restrictions at the time to fully compensate for the environmental change (compare Figs. 3 and 6). The fact that the catch decline did not steepen during the hydrosystem development is likely the result of a return to favorable ocean conditions which compensated for the adverse effects of the dams (compare Figs. 4 and 6), and the failure of the stocks to increase with the rebuilding efforts in the 1980s (compare Figs. 5 and 6) was likely in part the result of unfavorable ocean conditions, which have counteracted improvements in smolt passage survival.

This revised interpretation for the Columbia River stock decline may never be fully supported, because of the lack of long-term historical data on fish survival. In any case, it is clear that the coincidence of major natural and anthropogenic events did occur and that the fishery decline cannot be explained by anthropogenic factors alone. Realizing that natural and anthropogenic processes interact over decadal scales, the community of Columbia River scientists and managers has embarked on a new ecosystem perspective for managing the

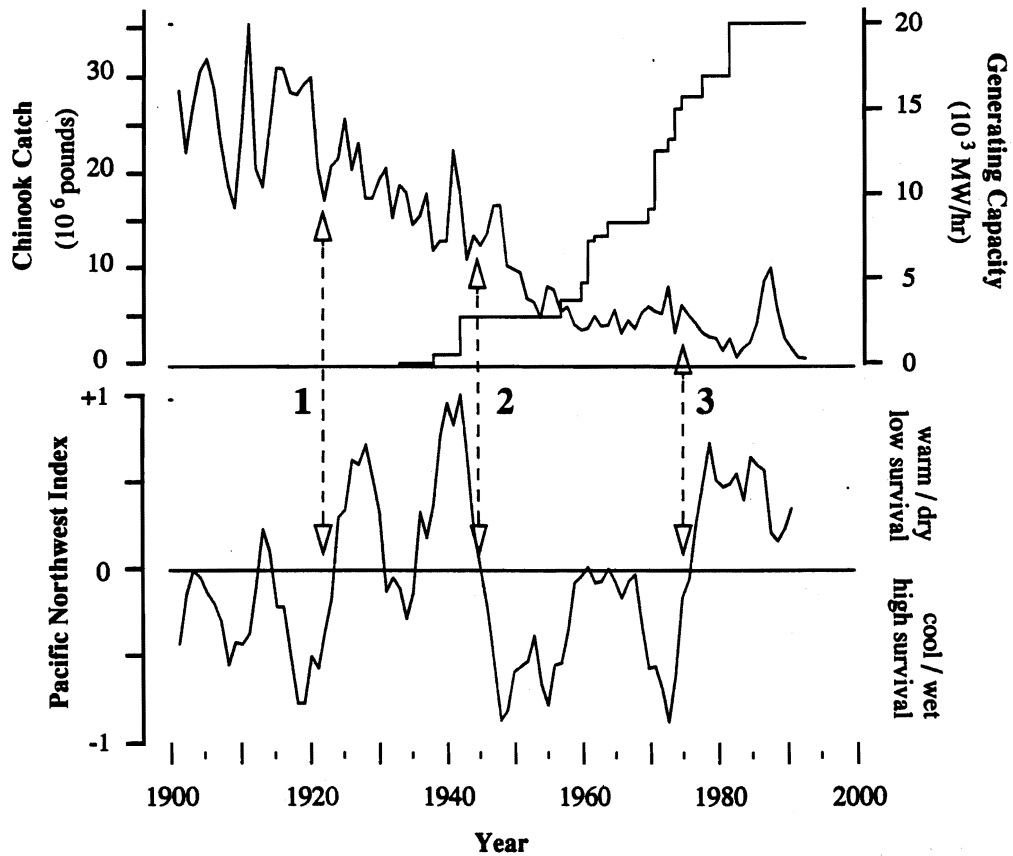

Figure 9. Major reversals in the Pacific Northwest Index (PNI) were concomitant with the beginning of Columbia River chinook salmon harvest decline (1), the initiation of hydropower development (2), and the beginning of the salmonid transportation program (3).

resource. The current focus is on the effects of climate, but an expanding ecosystem perspective, including such factors as fish physiology, behavior, and genetics, will lead to a more realistic understanding of the limitations and opportunities available to improve the Columbia River.

Summary

The influence of decadal scale climatic variations on the decline of Columbia River salmon was not realized until recently. I evaluated the implications of this omission using a stock recruitment model with climatic and anthropogenic factors. I concluded that fisheries managers over the past century have misinterpreted the anthropogenic impacts on Columbia River salmon. In particular, I suggest three major events have been misinterpreted: 1) managers overestimated the significance of harvest on the catch decline after 1920 by not accounting for climatic changes that lowered ocean survival at this time, 2) managers underrepresented the detrimental effects of the hydrosystem by not accounting for the contribution of good ocean survival during the years of hydrosystem development and, 3) managers underestimated the success of stock rebuilding measures in the last two decades because the concomitant poor ocean survival was not accounted for. I also suggest that the fisheries community is now evolving an ecosystem approach that considers both environmental and anthropogenic impacts on salmon.

Citations

- Anderson, J., J. Hayes, P. Shaw, and R. Zabel. 1996. Columbia River salmon passage model (CRiSP.1.5), 220 p. University of Washington, School of Fisheries, WH-10, Seattle, WA 98195.
- Beamish, R. J. 1995. Climate change and northern fish populations. *Can. Spec. Publ. Fish. Aquat. Sci.* 121:739 p.
- Coronado-Hernandez, M. C. 1995. Spatial and temporal factors affecting survival of hatchery-reared chinook, coho and steelhead in the Pacific Northwest. Ph.D. Thesis, University of Washington, Seattle, 235 p.
- Ebbesmeyer, C. C., and R. M. Strickland. 1995. Oyster condition and climate: Evidence from Willapa Bay. Washington Sea Grant Program, Univ. Washington, Seattle, Publ. WSG-MR 95-02, 11 p.
- Lee, K. N. 1993. *Compass and gyroscope: Integrating science and politics for the environment.* Island Press, Washington, DC, 243 p.

- Lichatowich, J. A., and L. E. Morbrand. 1995. Analysis of chinook salmon in the Columbia River from an ecosystem perspective. Report to Bonneville Power Administration, Contract DE-AM79-92BP25105, 102 p. (Available from Bonneville Power Administration, Public Information Center-CKPS-1, P. O. Box 3621, Portland, OR 97208.)
- Muir, W. D., S. G. Smith, E. E. Hockersmith, S. Achord, R. F. Absolon, P. A. Ocker, B. M. Eppard, T. E. Ruehle, J. G. Williams, R. N. Iwamoto, and J. R. Skalski. 1996. Survival estimates for the passage of yearling chinook salmon and steelhead through Snake River dams and reservoirs, 1995. Report to U.S. Army Corps of Engineers, Contract E86940119, and Bonneville Power Administration, Contract DE-A179-93BP10891, 150 p.
- U.S. Department of Commerce, National Oceanic and Atmospheric Administration, 1995. Proposed recovery plan for Snake River salmon, 490 p. (Available from Environmental and Technical Services Division, National Marine Fisheries Service, 525 NE Oregon Street, Suite 500, Portland, OR 97232-2737.)
- Williams, J. G., and G. M. Matthews. 1995. A review of flow and survival relationships for spring and summer chinook salmon, *Oncorhynchus tshawytscha*, from the Snake River Basin. Fish. Bull., U.S. 93:732-740.

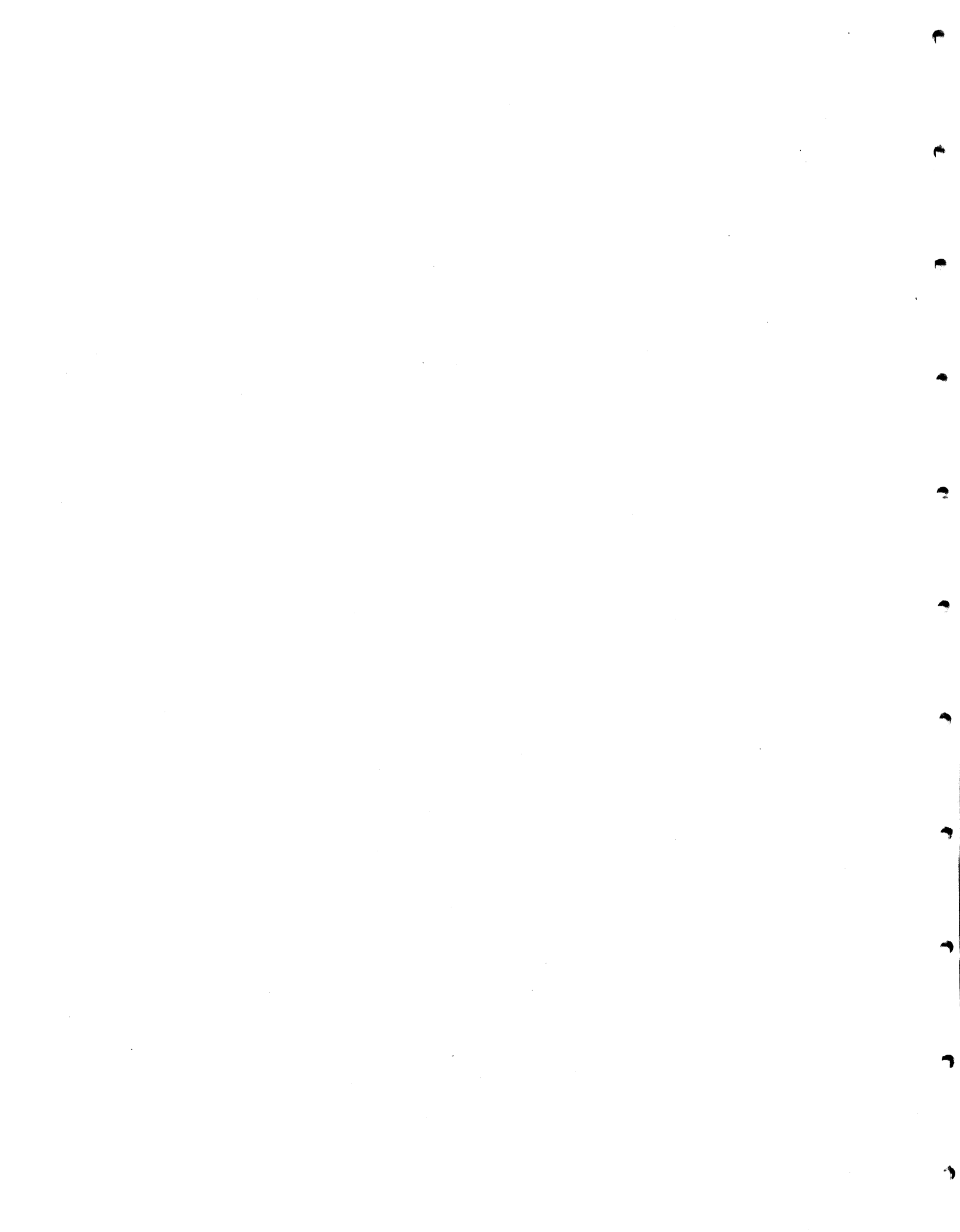

**Interannual Variations in Northeast Pacific Marine
Habitats and the Effects on Marine Survival of Salmonids**



COASTAL OCEAN CIRCULATION OFF OREGON: RECENT OBSERVATIONS OF SPATIAL AND TEMPORAL VARIABILITY

Jack A. Barth and Robert L. Smith

College of Oceanic and Atmospheric Sciences
Oregon State University
104 Ocean Admin. Bldg
Corvallis, OR 97331-5503

Ocean circulation off the northwest coast of the United States is driven by a variety of mechanisms, the most important of which is the seasonally varying wind stress. The response of the coastal ocean to strong equatorward ("upwelling-favorable") winds during the summer, described for example off the Oregon coast based on a number of past studies (e.g., Huyer 1983), consists of net offshore transport in the surface Ekman layer, upwelling of cold, saline water near the coast, and the formation of a strong alongshore coastal jet that is in geostrophic balance with the upwarded isopycnals. Winds become predominantly upwelling-favorable after the "spring transition" (Huyer et al. 1979), and the upwelling regime persists through the summer and early fall before returning to winter conditions after a fall transition. During the upwelling regime, the vertical structure of the alongshore velocity field consists of a southward coastal jet in the upper water column extending down to 50-75 m depth, with maximum speeds near the surface of up to 1 knot, and a more sluggish poleward undercurrent near the bottom over the outer continental shelf (Huyer et al. 1978).

The summer upwelling circulation is affected on short time scales by changes in the wind stress on 2- to 10-day time scales (Huyer 1983). On longer time scales, the timing and intensity of the upwelling circulation varies from year to year (Huyer et al. 1979, Strub and James 1988) under the influence of interannual variability in the atmospheric driving and in coupled ocean-atmosphere phenomena, for example El Niño (Huyer and Smith 1985). The following discussion will not focus on interannual variability of coastal ocean circulation, except to point out differences between two particular years along the Oregon coast (1994 and 1995), concentrating instead on a description of spatial variation of the upwelling circulation associated with the interaction of a strong upwelling jet with a coastal promontory. Spatial variability in the coastal upwelling circulation is readily apparent in satellite sea surface temperature (SST) maps, an example of which is shown in Figure 1. Spatial variability is an important factor to consider, together with temporal variability, when assessing the influence of the coastal ocean on biological productivity and the transport of biogeochemical and anthropogenic material.

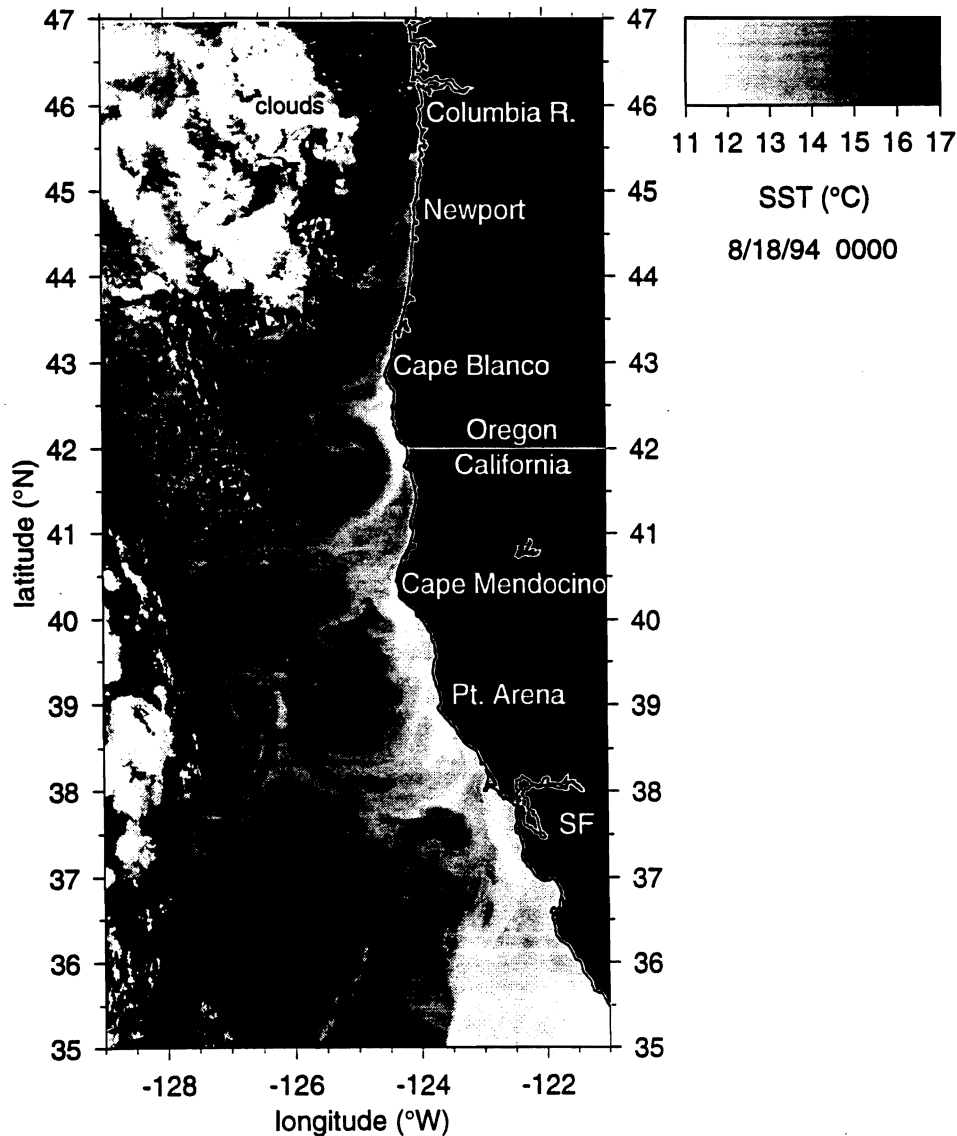
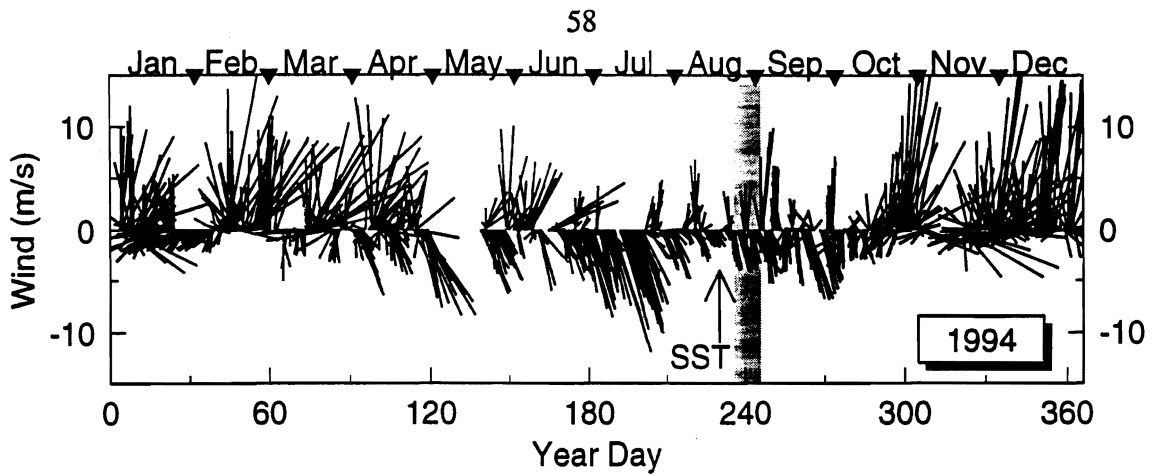

Figure 1. Top: Vector winds (m/s) for 1994 measured at the NOAA CMAN station in Newport, Oregon. The date of the sea surface temperature image is indicated by an arrow and the time of the 10-day R/V *Wecoma* cruise is denoted by a gray bar. Bottom: Satellite infrared sea surface temperature (°C) from 18 August 1994 showing cold, upwelled water near the coast separated from warmer water offshore by a meandering front.

The Coastal Jet Separation Experiment

Recently, scientists at Oregon State University (OSU) have been studying the region near Cape Blanco, Oregon in an effort to understand how and why the strong alongshore coastal upwelling jet turns offshore, crosses the steep topography of the continental margin, and becomes an oceanic jet (Barth et al. 1994, Barth and Smith 1996, Smith et al. 1996). The Cape Blanco region was chosen because historical observations (Huyer 1990, Smith 1992) and satellite imagery (Fig. 1) suggest that this is a dividing point between a region to the north of the cape where upwelling is fairly well confined to inshore of the continental shelf break (approximately the 200-m isobath) and a region to the south of the cape where a meandering equatorward jet and upwelled water extend well seaward of the continental margin (Kosro and Huyer 1986).

The observational component of the Coastal Jet Separation Experiment consisted of three hydrographic and velocity surveys during 1994 and 1995 using the Research Vessel (RV) *Wecoma*, tracking surface drifters and analyzing satellite SST imagery. The hydrographic data were collected using a towed, undulating vehicle, SeaSoar (Pollard 1986), which cycles rapidly from the surface to depth while towed at 8 knots (4 m/s) behind the RV *Wecoma*. The majority of the conductivity-temperature-depth data was collected by towing the SeaSoar on a bare cable cycling the vehicle between 0 and 120 m every 4 minutes. The result is hydrographic data with very high spatial resolution (1 km between along-track surface points) obtained rapidly (cross-shelf sections in 2-3 hours and large-area maps in 1-2 days) so that a detailed "snapshot" of the system can be studied. Over the shallow continental shelf, the SeaSoar was flown from 0 to 55 m cycling every 1.5 minutes, resulting in along-track profile spacing as little as one-third of a kilometer. The SeaSoar was also towed occasionally on a cable equipped with aerodynamic fairing to reduce drag; this allows the vehicle to cycle between the surface and in excess of 300 m every 8 minutes.

The seasonal cycle in the wind stress is apparent in the 1994 winds as measured at Newport, Oregon (Fig. 1, top). July was a month of typical, strong upwelling-favorable winds; however, August was a period of anomalously weak equatorward winds. An SST image from 18 August 1994 (Fig. 1, bottom) reveals a band of cold upwelled water near the coast, confined to inshore from the continental shelf break north of Cape Blanco (the wide cold feature near lat. 44°N is the influence of Heceta Bank--note the bottom topography in Fig. 3) and extending much farther seaward south of the Cape. The equatorward upwelling jet, associated with the temperature front between cold upwelled water inshore and warmer water offshore, meanders westward at Cape Blanco but returns toward the coast downstream in a counter-clockwise bend before meandering over 300 km offshore near lat. 41°N. A ship survey of the region on 25 to 30 August 1994 (Fig. 2) confirmed the existence of the strong alongshore coastal jet north of the Cape as exemplified by the strong gradient in dynamic height found there. Geostrophic currents flow along contours of dynamic height, and their speed is inversely proportional to the distance between the contours. The dynamic height map shows continuity of the southward jet with a counter-clockwise (cyclonic) eddy roughly 80 km in diameter offshore from the Cape. A second dynamic height map reveals the

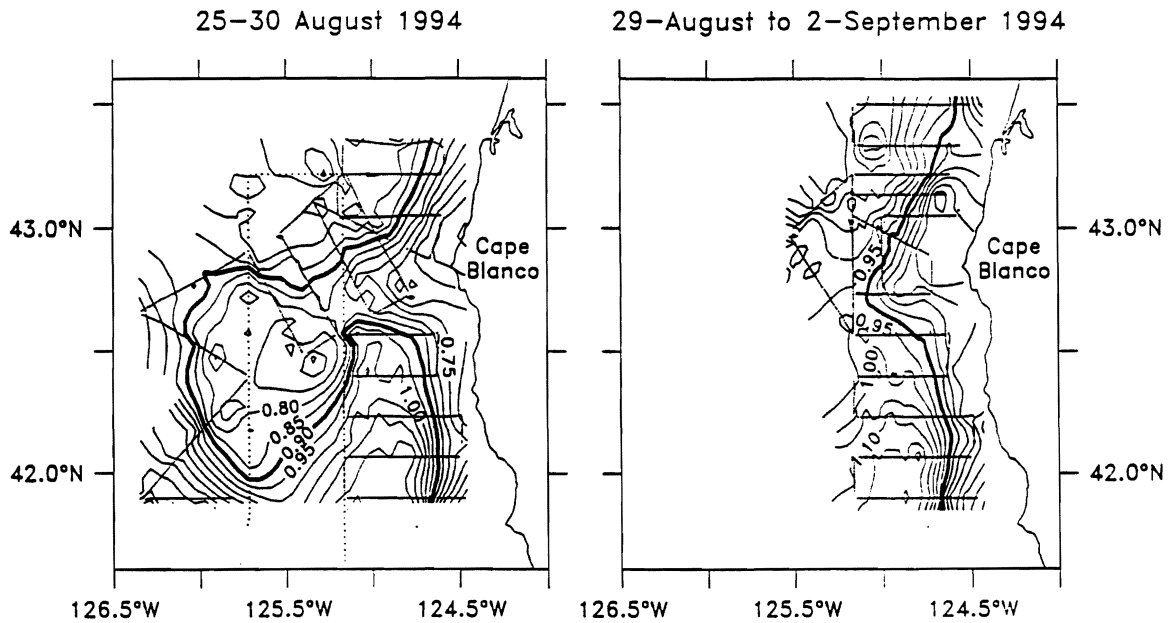

Figure 2. Contour maps of dynamic height normalized by the acceleration of gravity ($\Delta D_{23/55}/g$ in meters) from SeaSoar surveys during 25-30 August 1994 (left) and 29 August to 2 September 1994 (right). Individual conductivity-temperature-depth profiles are denoted by dots along the ship track and the 0.9-m dynamic height contour is highlighted to emphasize the pinching off of a counter-clockwise (cyclonic) eddy off Cape Blanco, Oregon.

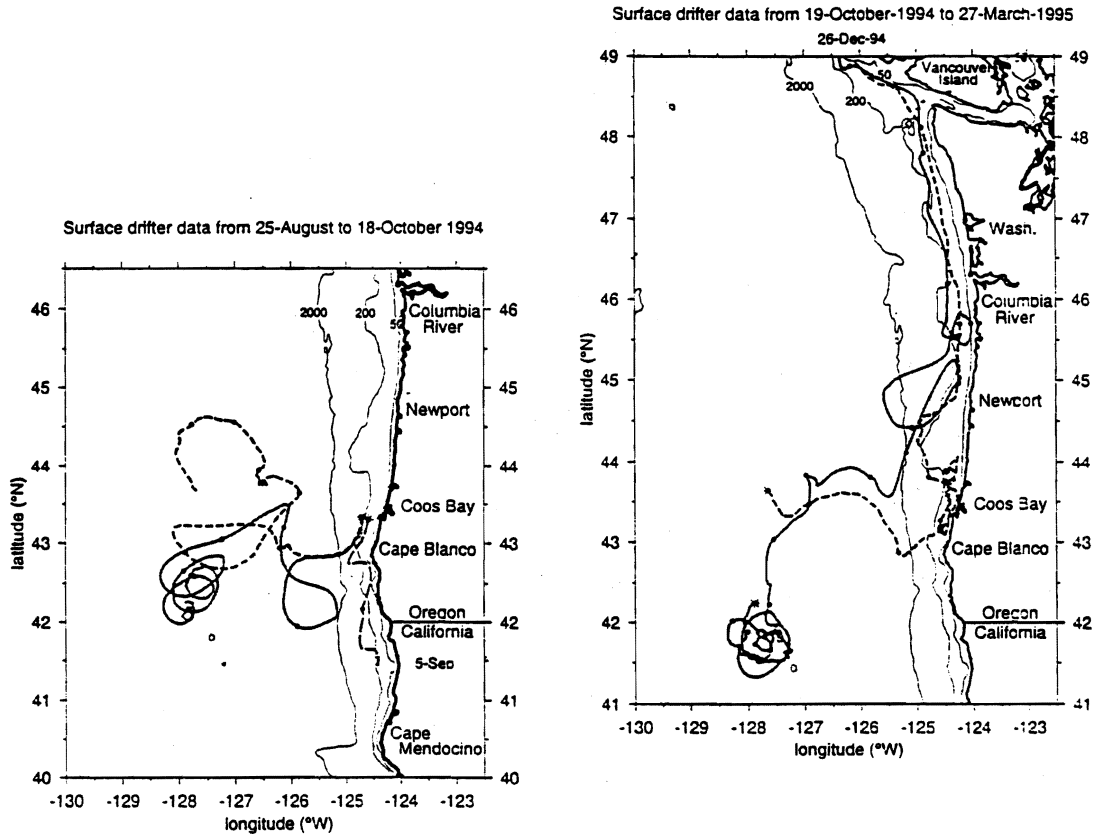

Figure 3. Trajectories of three satellite-tracked drifters released on 25 August 1994 at the beginning of the SeaSoar surveys shown in Figure 2. Release points off Coos Bay are denoted by asterisks; marks along the drifter tracks are at weekly intervals. Trajectories are shown from the release until 18 October 1994 (left), where the most landward drifter (long dashed line) failed on 5 September 1994, and for the remaining two drifters through 27 March 1995 (right), where the drifter denoted by the solid line reached lat. 49°N on 26 December 1994.

pinching off of the eddy and a reconnection of the equatorward jet on the inshore side, as denoted by the 0.9-m dynamic height contour. This creation of a large counter-clockwise eddy is termed "cyclogenesis" and is a result of a flow-topography interaction between the coastal upwelling jet and the Cape. The eddy contains water of coastal origin, and this process is an important mechanism for injecting biologically important material into the deep ocean.

Three satellite-tracked surface drifters were released across the coastal jet to the north of Cape Blanco (Fig. 3) at the beginning of the survey. All three drifters were initially swept offshore by the separating jet, but the most inshore drifter (long dashed curve) split from the other two to follow an inshore pathway to the south (compare with the 0.8-m dynamic height contour in Fig. 2). The other two drifters moved together around the northern edge of the cyclonic eddy at speeds of up to 0.6 m/s, before one drifter (dashed curve) moved off to the northwest while the other drifter made one complete revolution of the eddy before exiting to the north. Both drifters then made counter-clockwise revolutions around a cold eddy (near lat. 43°N, long. 126.5°W in the SST image) formed earlier (July) in the upwelling season. One drifter (dashed curve) again left the cyclonic feature to the north and spent the next 5 weeks in the low velocity region well offshore from central Oregon, while the other drifter remained trapped in the counter-clockwise eddy. In mid-October, the winds became south-southwesterly through the fall transition (Fig. 1) and the circulation responded as shown by drifter tracks in the right-hand panel of Figure 3. The drifter in the stagnant offshore area was swept back onto the continental shelf, returning very close to its deployment point after spending 2.5 months offshore. This demonstrated a Lagrangian pathway for passive particles to leave the coastal ocean, but to then return through the influence of seasonally and spatially varying circulation. The other drifter executed additional revolutions around the eddy before also being swept onto the central Oregon shelf. Since the cold offshore eddy was formed in July, this indicated a minimum eddy lifetime of 4-5 months. Finally, both drifters were swept rapidly poleward by the Davidson Current (Jones 1918) transiting to north of Vancouver Island.

In 1995, winds became upwelling-favorable for an extended period beginning in mid-May (Fig. 4, top). A satellite SST image from 18 May 1995 (Fig. 4, bottom) showed a relatively narrow band of cold, upwelled water near the coast during this early part of the upwelling season. The southward-upwelling jet and front meandered only slightly near Cape Blanco (compare the SST image in Fig. 1). A ship survey of the Cape Blanco region (not shown) confirmed the existence of the nearly straight southward jet near the continental shelf break. Five satellite-tracked surface drifters were released across the continental margin north of Cape Blanco on 21 May 1995 (Fig. 5, left). The four inshore drifters transited rapidly to the south at speeds up to 0.6 m/s, again demonstrating the relatively straight alongshore flow (compare with Fig. 3, left). The drifter released farthest west was placed in the surface salinity minimum associated with the Columbia River influence offshore from the coastal upwelling jet and front, and transited slowly (0.05-0.25 m/s) to the southwest. Throughout the remainder of the upwelling season, the drifters were swept equatorward in the eastern boundary current region by a meandering jet (Fig. 5, right). Evidence for eddies, meanders,

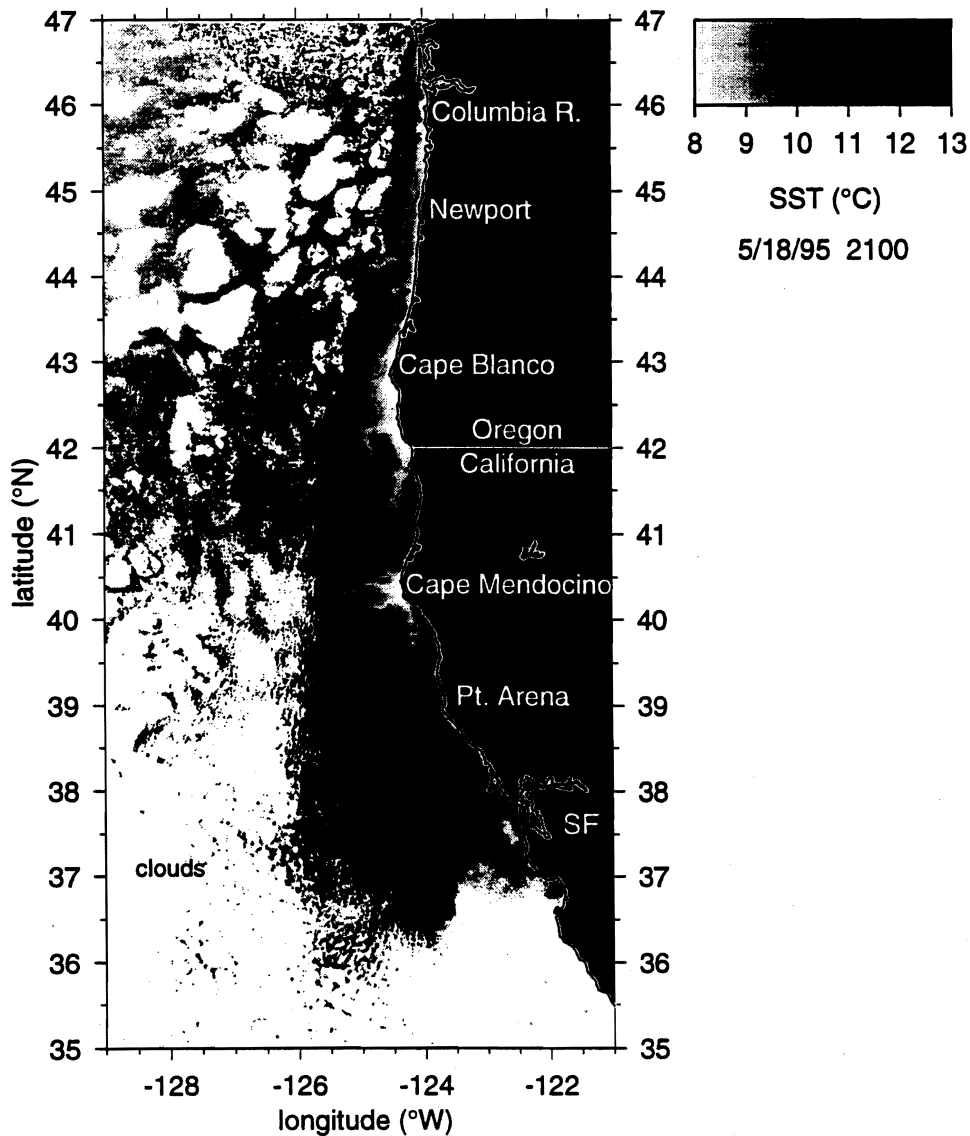
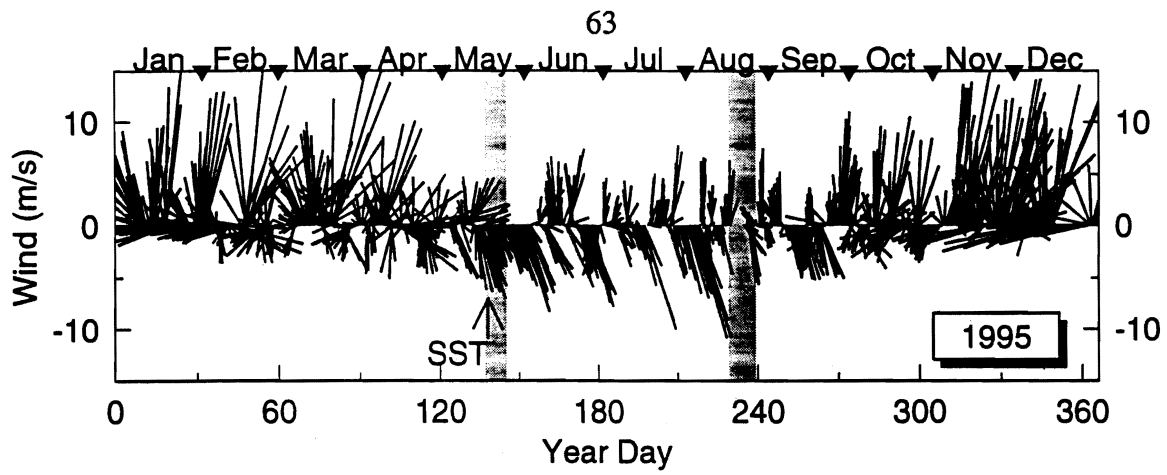

Figure 4. Top: Vector winds (m/s) for 1995 measured at the NOAA CMAN station in Newport, Oregon. The date of the sea surface temperature image is indicated by an arrow and the times of two R/V *Wecoma* cruises are denoted by gray bars. Bottom: Satellite infrared sea surface temperature (°C) from 18 May 1995 showing a relatively narrow band of cold, upwelled water near the coast at the beginning of the upwelling season.

Surface drifter data from 21-May-1995 to 7-February-1996

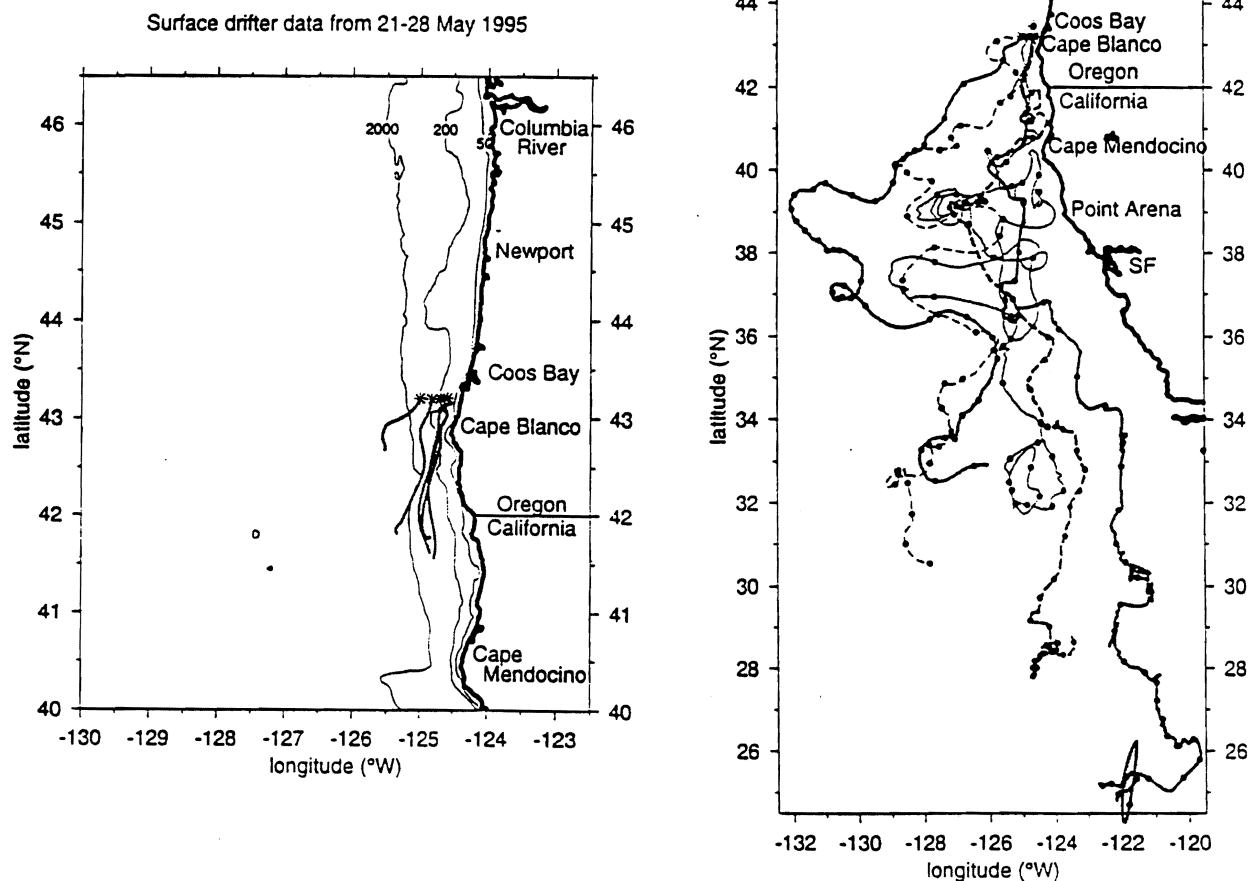

Figure 5. Trajectories of five satellite-tracked drifters released on 21 May 1995 off Coos Bay, Oregon. Drifter tracks are shown for 1 week (left) and for 8 1/2 months (right) after the release. For the early trajectories, drifter tracks are all drawn as solid curves while in the right-hand panel tracks are differentiated by line type. The drifter released second-farthest west failed on 30 May 1995. An additional drifter (thin dashed curve) is included in the right-hand panel beginning on 31 May 1995 just to the north of the earlier five-drifter release latitude.

swift jets, and more sluggish flow far offshore (e.g., near lat. 37-40°N, long. 129-132°W) exists in the drifter tracks. These Lagrangian trajectories confirm the hypothesis that the separating coastal upwelling jet off Oregon contributes significantly to the meandering jet now accepted as making up a large fraction of the equatorward flow in the California Current System (Huyer et al. 1991). None of the drifters released in May returned to the coast, nor did they remain or return to their release latitude. This demonstrates that material carried by the coastal upwelling jet off Oregon early in the upwelling season can be carried far from its point of origin by the swift, relatively linear southward flow.

A ship survey and drifter release was conducted near the end of August 1995 after a period of typical strong upwelling-favorable wind stress (Fig. 4, top). A map of dynamic height (Fig. 6, left) shows a strong southward jet centered on the continental shelf break north of Cape Blanco which then meandered offshore near the Cape and separated from the coast to become an oceanic jet. The jet gained in strength downstream from the Cape, in part from a flow contribution that joined the separating jet from the northwest (lat. 43.25°N, long. 125.5°W) and was associated with flow around Heceta Bank upstream. Five satellite-tracked drifters were released on the continental shelf north of Cape Blanco (Fig. 6, right) and initially all were carried to the south in the upwelling jet. While the most inshore drifter grounded south of Cape Blanco, the other four drifters were swept swiftly (speeds in excess of 1 m/s) offshore in the separating jet. The drifters executed both clockwise (anticyclonic) and cyclonic loops associated with the strong, unstable meandering jet. Drifters released on the shelf transit over 400 km from the coast before turning southward and delineating the equatorward eastern boundary current jet with its core located between long. 127°W and 128°W near lat. 40°N. As the winds become south-southwesterly in the fall, the circulation responds, and all four drifters were swept shoreward between lat. 37°N and 39°N. By 7 February 1996, one drifter (thin dashed curve) had come ashore south of Cape Mendocino, another drifter (thick solid curve) was transiting poleward over the continental slope, one drifter (thin solid curve) had exited from a cyclonic eddy near lat. 38°N, long. 127°W and was transiting shoreward to the northwest, and the fourth drifter (thick dashed curve) stopped transmitting over the continental slope just north of Point Arena. In summary, as a result of the jet-topography interaction which leads to a meandering jet with a substantial east-west component, passive material released on the shelf in the coastal upwelling jet north of Cape Blanco, Oregon can return to the coast within approximately 5 degrees of latitude to the south under the influence of the seasonal change in wind stress and the resulting ocean circulation.

Discussion

The results presented here demonstrate the existence of strong spatial variability in the upwelling circulation off the Oregon and northern California coasts. Understanding the processes which lead to and control this spatial variability is critical in assessing the influence of ocean circulation on biological productivity and the transport of biogeochemical and anthropogenic material onto and off of the continental shelf. The existence of separated coastal upwelling jets, recirculating eddies, meandering equatorward jets, and return flows to

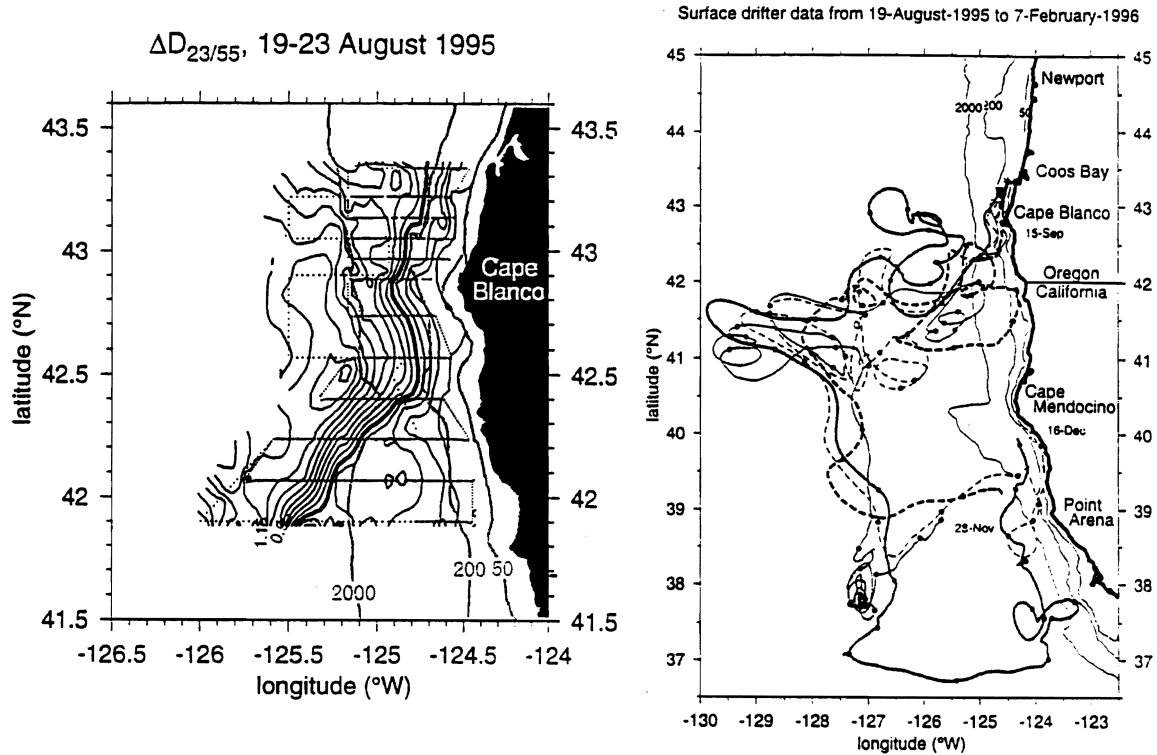

Figure 6. Left: Contour map of dynamic height normalized by the acceleration of gravity ($\Delta D_{23/55}/g$ in meters) from a SeaSoar survey during 19-23 August 1995. Individual conductivity-temperature-depth profiles are denoted by dots along the ship track and the 50, 200, and 2000-m isobaths are shown in gray. The 0.8-m dynamic height contour is highlighted to show the separation of the coastal jet from the continental shelf. Right: Trajectories of five satellite-tracked drifters released on 19 August 1995 off Coos Bay, Oregon. The drifter released farthest north and most landward (thick solid curve) ran aground just south of Cape Blanco on 15 September 1995, one drifter (thin solid curve) failed on 28 November 1995 just offshore of the 2000-m isobath north of Pt. Arena, and one drifter (thin dashed curve) came ashore south of Cape Mendocino on 16 December 1995.

the coast has been documented. There is a distinct difference in the behavior of the system early (May) versus later (August) in the upwelling season. In May, the coastal jet remains relatively straight as it transits around Cape Blanco, and drifters released on the shelf are flushed far to the south in the eastern boundary current region. This differs from the behavior later in the upwelling season (August) when the upwelling circulation is more fully developed and the jet-topography interaction creates a spatially complex flow pattern that can retain drifters released on the shelf near their release latitude, enabling their return to the continental margin after the seasonal winds change direction.

Finally, interannual changes in the strength and timing of upwelling occur and are important to levels of biological productivity. While this paper has not concentrated on interannual variability, marked differences exist between the two August realizations presented here. In August 1994, upwelling-favorable winds were anomalously weak and the jet-cape interaction resulted in the generation of cyclonic eddies. In August 1995, after a month of typical strong upwelling-favorable winds, the coastal jet was fully separated from the coast near Cape Blanco. To better understand interannual variability, both further understanding of dynamic processes (which lead to strong spatial variability) and long time series of oceanographic and atmospheric conditions are needed.

Acknowledgments

We are indebted to Jane Huyer (OSU) for her encouragement during this research and for her insights on coastal and eastern boundary current circulation. Thanks also to the OSU Marine Technicians, Marc Willis, Tim Holt, Linda Fayler, and Mike Hill, who were responsible for the highly successful SeaSoar operations. The officers and crew of the RV *Wecoma* performed superbly--only occasionally would they comment on the fact that we insisted on towing the SeaSoar in an east-west direction, invariably in the trough of the prevailing northwest summer swell. Ted Strub and Corinne James (OSU) generously provided the satellite imagery. This work was funded by National Science Foundation Grant OCE-9314370.

Citations

- Barth, J. A., and R. L. Smith. 1996. Separation of a coastal upwelling jet and pathways for cross-shelf exchange: A Lagrangian perspective. *Eos Trans. AGU, Ocean Sciences Meet. Suppl.* 77(3):130.
- Barth, J. A., R. L. Smith, and A. Huyer. 1994. Separation of a coastal jet and cyclogenesis during coastal upwelling. *Eos Trans. AGU, Fall Meet. Suppl.* 75(44):345.

- Huyer, A. 1983. Coastal upwelling in the California Current system. *Prog. Oceanogr.* 12:259-284.
- Huyer, A. 1990. Shelf circulation. *In* B. LeMehaute and D. M. Hanes (editors), *Ocean engineering science (The Sea, Vol. 9, Pt. A)*, p. 423-466. Wiley, New York.
- Huyer, A., P. M. Kosro, J. Fleischbein, S. R. Ramp, T. Stanton, L. Washburn, F. P. Chavez, T. J. Cowles, S. D. Pierce, and R. L. Smith. 1991. Currents and water masses of the coastal transition zone off northern California, June to August 1988. *J. Geophys. Res.* 96:14809-14831.
- Huyer, A., and R. L. Smith. 1985. The signature of El Niño off Oregon, 1982-83. *J. Geophys. Res.* 90:7133-7142.
- Huyer, A., R. L. Smith, and E. J. C. Sobey. 1978. Seasonal differences in low-frequency current fluctuations over the Oregon continental shelf. *J. Geophys. Res.* 83:5077-5089.
- Huyer, A., E. J. C. Sobey, and R. L. Smith. 1979. The spring transition in currents over the Oregon continental shelf. *J. Geophys. Res.* 84:6995-7011.
- Jones, E. L. 1918. The neglected waters of the Pacific Coast. *Spec. Publ. U.S. Coast Geodetic Survey* 48:1-21.
- Kosro, P. M., and A. Huyer. 1986. CTD and velocity surveys of seaward jets off northern California, July 1981 and 1982. *J. Geophys. Res.* 91:7680-7690.
- Pollard, R. 1986. Frontal surveys with a towed profiling conductivity/temperature/depth measurement package (SeaSoar). *Nature* 323:433-435.
- Smith, R. L. 1992. Coastal upwelling in the modern ocean. *In* C. P. Summerhayes, W. L. Prell, and K-C. Emeis (editors), *Upwelling systems: Evolution since the early Miocene*, p. 9-28. Geological Soc. London *Spec. Publ.* 64.
- Smith, R. L., J. A. Barth, and A. van Geen. 1996. The coastal upwelling jet: A link between coastal upwelling and the California Current. *Eos Trans. AGU, Ocean Sciences Meet. Suppl.* 77(3):130.
- Strub, P. T., and C. James. 1988. Atmospheric conditions during the spring and fall transitions in the coastal ocean off the western United States. *J. Geophys. Res.* 93:15561-15584.

THE FOOD ENVIRONMENT OF JUVENILE SALMONIDS:
YEAR-TO-YEAR VARIATIONS IN ZOOPLANKTON ABUNDANCE
OVER THE INNER-MIDDLE SHELF OFF CENTRAL OREGON--1969-78

William T. Peterson

NOAA/NMFS Hatfield Science Center
2030 Marine Science Dr.
Newport, OR 97365

A number of statistical studies have demonstrated that the survival of coho salmon (*Oncorhynchus kisutch*) in the ocean is correlated positively with the strength of coastal upwelling (Fig. 1) during the summer of smolt out-migration (first noted by Gunsolus in 1978; reviewed in Percy 1992). The causal variable(s) which might account for the positive correlations are not known; in papers that discuss such correlations, it is often stated that summers having good upwelling represent "good ocean conditions" and summers having low upwelling represent "poor ocean conditions." The purpose of this paper is to attempt to improve the definition of the term "ocean conditions," using as a proxy the abundance of zooplankton over the continental shelf.

Methods

As an index of ocean conditions, two kinds of data are presented, the Bakun upwelling index and the speed and direction of winds measured at the Newport, OR South Jetty. The wind data are presented as progressive vector diagrams; data shown here have been published (Peterson and Miller 1975, 1976).

The biological data are from a series of zooplankton samples collected from June 1969 through 1972, and another series of samples collected during late-spring and summer of 1973, July/August 1977, and July/August 1978. The 1969-72 samples were collected as part of a survey of copepods and ichthyoplankton carried out by Sally Richardson, Bill Percy, and Charles Miller with the aid of Oregon Sea Grant funding. Results of this project have been published (e.g., Richardson and Percy 1977; Peterson and Miller, 1975, 1977). Most of the zooplankton samples were collected with a 20-cm bongo net fitted with 240- μ m-mesh plankton nets; zooplankton were enumerated by species and developmental stage. A summary of all data from 1969 to 1972 is published in a technical report (Peterson and Miller 1976).

The zooplankton data are presented in two ways. First, data for all years for a given species are pooled in a series of illustrations that show the seasonal cycle of abundance. Second, the data are broken out by abundance, by year, and for July/August (since these are the months for which the most data are available).

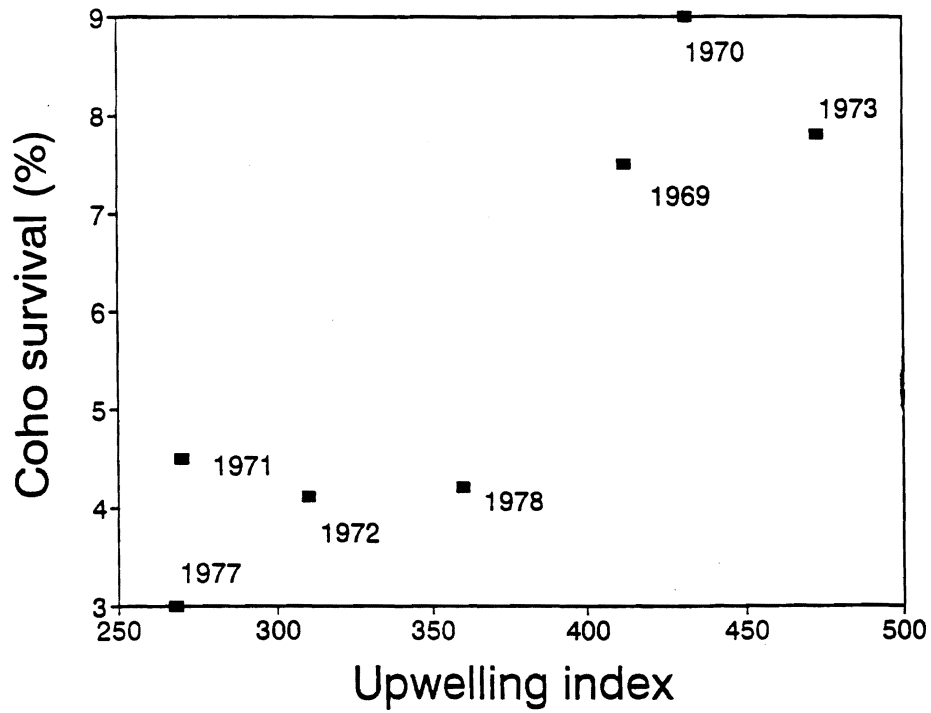

Figure 1. Relationship between upwelling index (summed for July and August) and survival of Oregon Production Index coho salmon for the seven years for which zooplankton data were available. The correlation coefficient for the linear relationship was 0.89.

Results

Wind Data

Upwelling-favorable winds (i.e., winds which blow southward) usually begin to blow in mid-April and continue through early September off central Oregon. The winds are never continuous from north to south; rather the pattern is punctuated by periods of either calm winds or reversals during which winds may blow from the south and east. The intermittency of the winds generates what are known as upwelling events. Figure 2 shows an example of each of the two patterns usually observed off central Oregon in summer. During 1969, 1970, and 1973, the winds were predominantly from the north with very little onshore set to the wind. During the summers of 1971 and 1972, there was a greater preponderance of winds from the east. The wind data from all 5 years may be summarized as follows:

<u>Year</u>	<u>Thousands of wind-kilometers</u>		<u>Number of events</u>	<u>Bakun upwelling index, 45°N (summed weekly values; May-August)</u>
	<u>S</u>	<u>E</u>		
1969	14	2	7	675
1970	22	1	9	782
1971	9	12	8	574
1972	38	15	11	624
1973	14	6.5	6	712

Read this table as follows: for 1969, if you multiplied wind speed by vector of direction, you would find that the wind "blew" a total of 14,000 km toward the south (i.e., from the north) and 2,000 km toward the east (i.e., from the west), from May through August. A comparison of south to east winds among years shows that winds were more easterly in 1971 and more southerly in the other years. The Bakun upwelling index is fairly well correlated with the southerly wind for all years but 1972.

Zooplankton (Copepods)

Highest zooplankton abundances are found within the upper 20 m of the water column over the inner- and mid-shelf (Peterson and Miller 1975, 1976). The dominant species are copepods and they are found in distinct ecological zones, parallel to the coast. A near-shore group is made up of *Acartia clausii*, *Centropages abdominalis*, and *Pseudocalanus mimus*. The offshore group is composed of *Acartia longiremis* and *Oithona similis*. The life history stages of *Calanus marshallae* are distributed across both zones, with eggs and nauplii near shore and older juveniles farther from shore. Relationships between zonation of copepod species, hydrography, and mechanisms for population retention are discussed in Peterson et al. (1979).

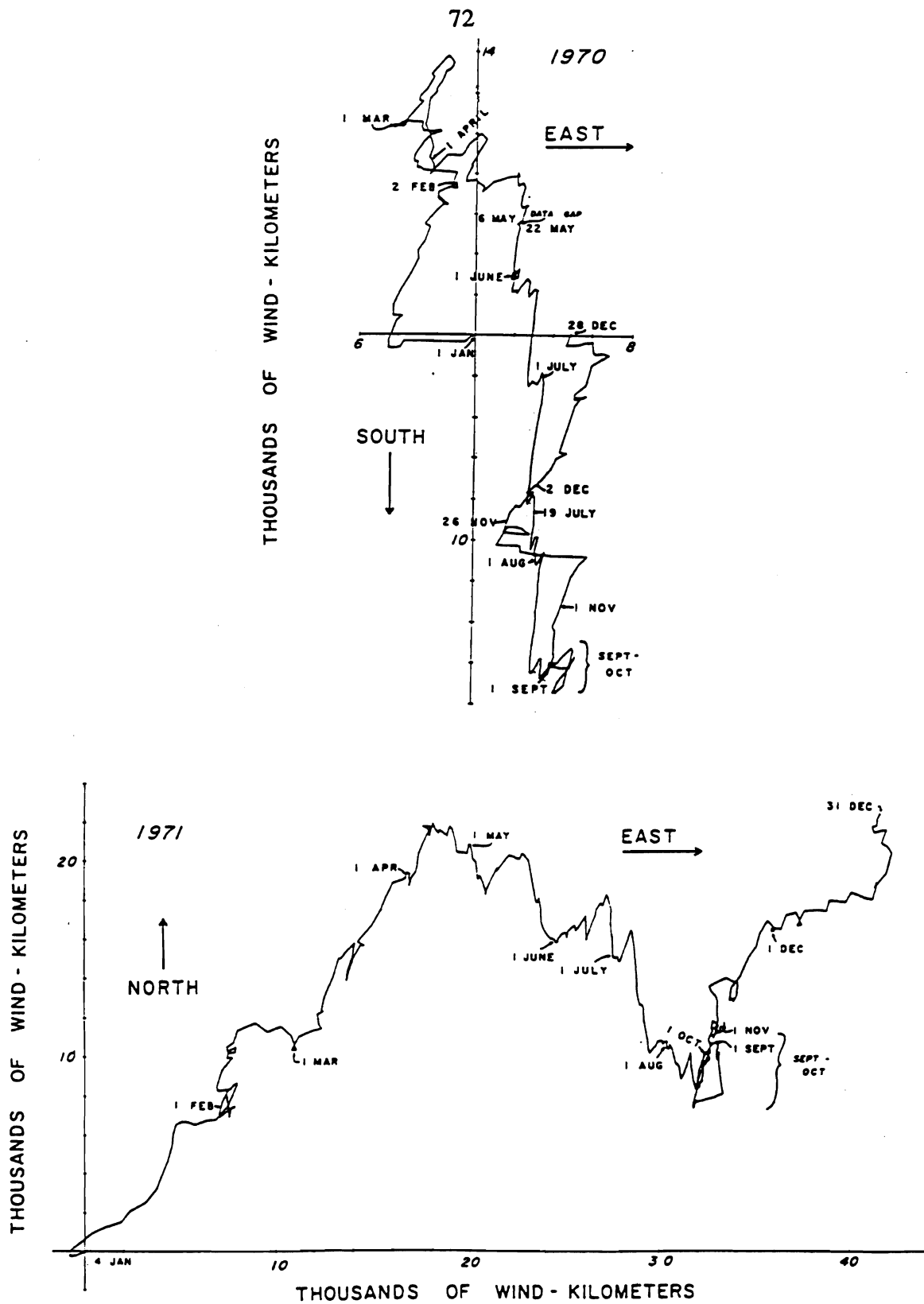

Figure 2. A progressive vector diagram of the winds at South Jetty, Newport, Oregon, for two contrasting years: 1970 and 1971.

The seasonal cycle of abundance is shown in Peterson and Miller (1977). Here, I show the climatological cycle (i.e., all data are pooled regardless of year) for 1969-73 and for 1978 for the dominant species. Considering first the small copepods (<1.5 mm length and <30 μg dry weight), the two species of *Acartia* have a common abundance pattern (Fig. 3); both populations begin to increase in numbers in early June; *A. clausii* reaches peak abundances in October, whereas *A. longiremis* peaks as early as mid-July. The main growth period for the copepods *Pseudocalanus mimus* and *Centropages abdominalis* is also June-October, with peak abundances in July. For the large copepod *Calanus marshallae* (adult length 3.5 mm and dry weight 350 μg), the population begins to increase in mid-February (Fig. 4). High numbers of adults can be seen throughout the spring and summer months.

Zooplankton (Euphausiids)

Euphausiids are one of the chief prey of juvenile coho salmon (Peterson et al. 1982; Emmett et al. 1986; Brodeur 1989; Brodeur and Percy 1990, 1992). Though one does not sample the adults and older juveniles quantitatively with small bongo nets, one can learn something of the distribution and abundance of adults by the presence or absence of eggs and larval stages. Based on the egg data shown in Figure 5, adults begin spawning in mid-April and continue to do so through the summer. Apart from the nauplii which showed a strong peak in summer, the other life-cycle stages are about equally abundant in spring as in summer. The presence of high numbers of eggs from May through August suggests that adult euphausiids are abundant throughout this period.

Relationships between zooplankton and juvenile coho salmon

The copepod data can be summarized in terms of total copepod biomass. Biomass was calculated by multiplying copepod numbers by weights of individuals. The table below summarizes these data along with abundances for euphausiid furcilia (juveniles) for data collected in July/August since those are the months for which the most data are available. These data can be compared to percent coho salmon survival:

	Small- copepod biomass (mg m^{-3})	<i>Calanus</i> biomass (mg m^{-3})	Euphausiid numbers (m^{-3})	Coho survival (%)
1969	187	38	79	7.5
1970	70	10	35	9.0
1971	43	10	51	4.5
1972	25	4	68	4.1
1973	99	7	171	7.8
1977	--	98	--	4.2
1978	85	32	0	3.0

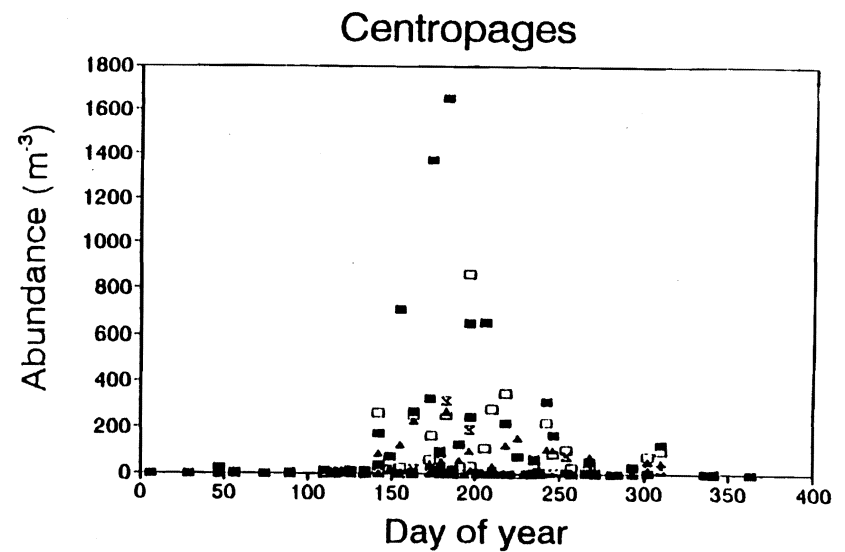
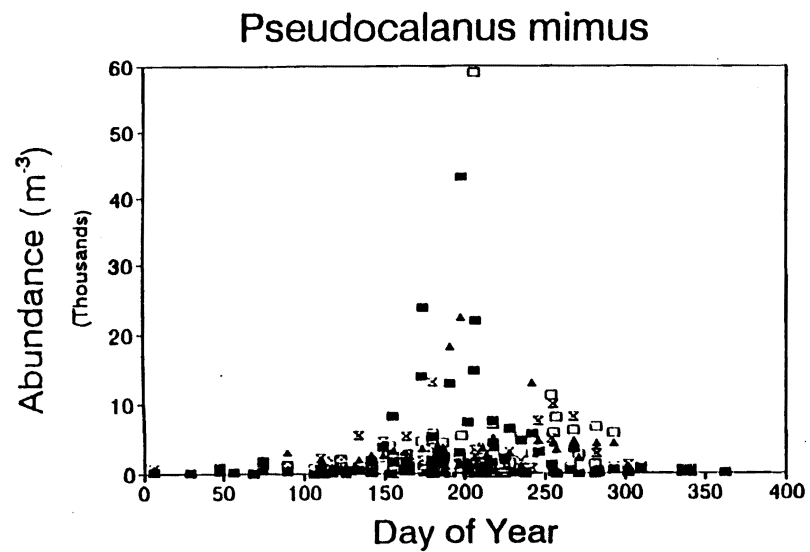
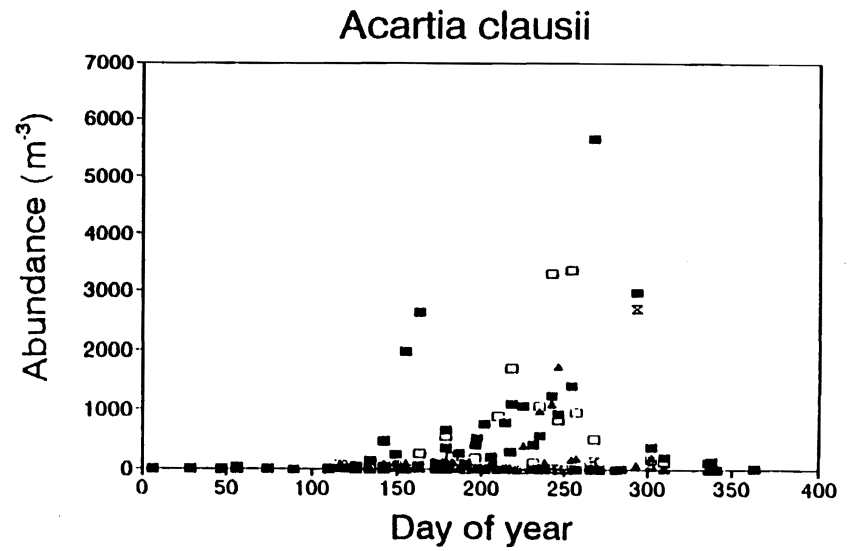
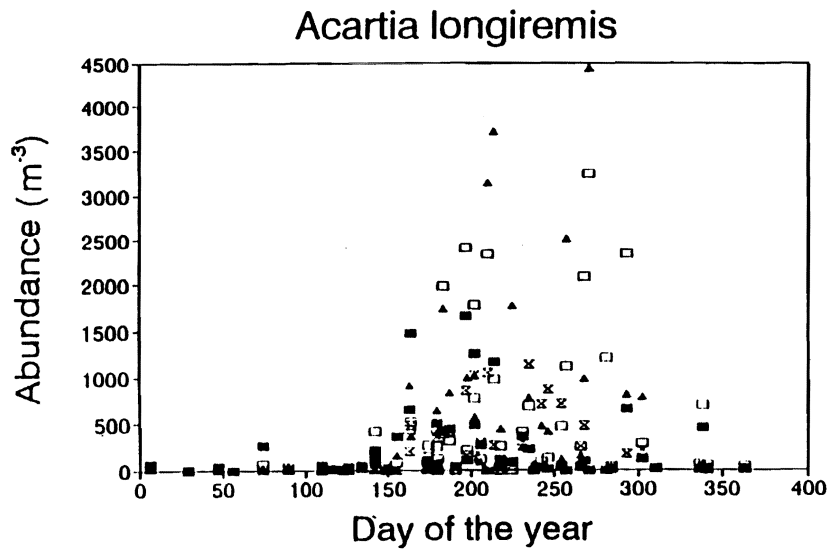

Figure 3. Seasonal cycle of abundance for the smaller copepod species, *Acartia longiremis*, *Acartia clausii*, *Pseudocalanus mimus* and *Centropages abdominalis*. In all cases, the populations do not begin to increase exponentially until the first of June (Day 152).

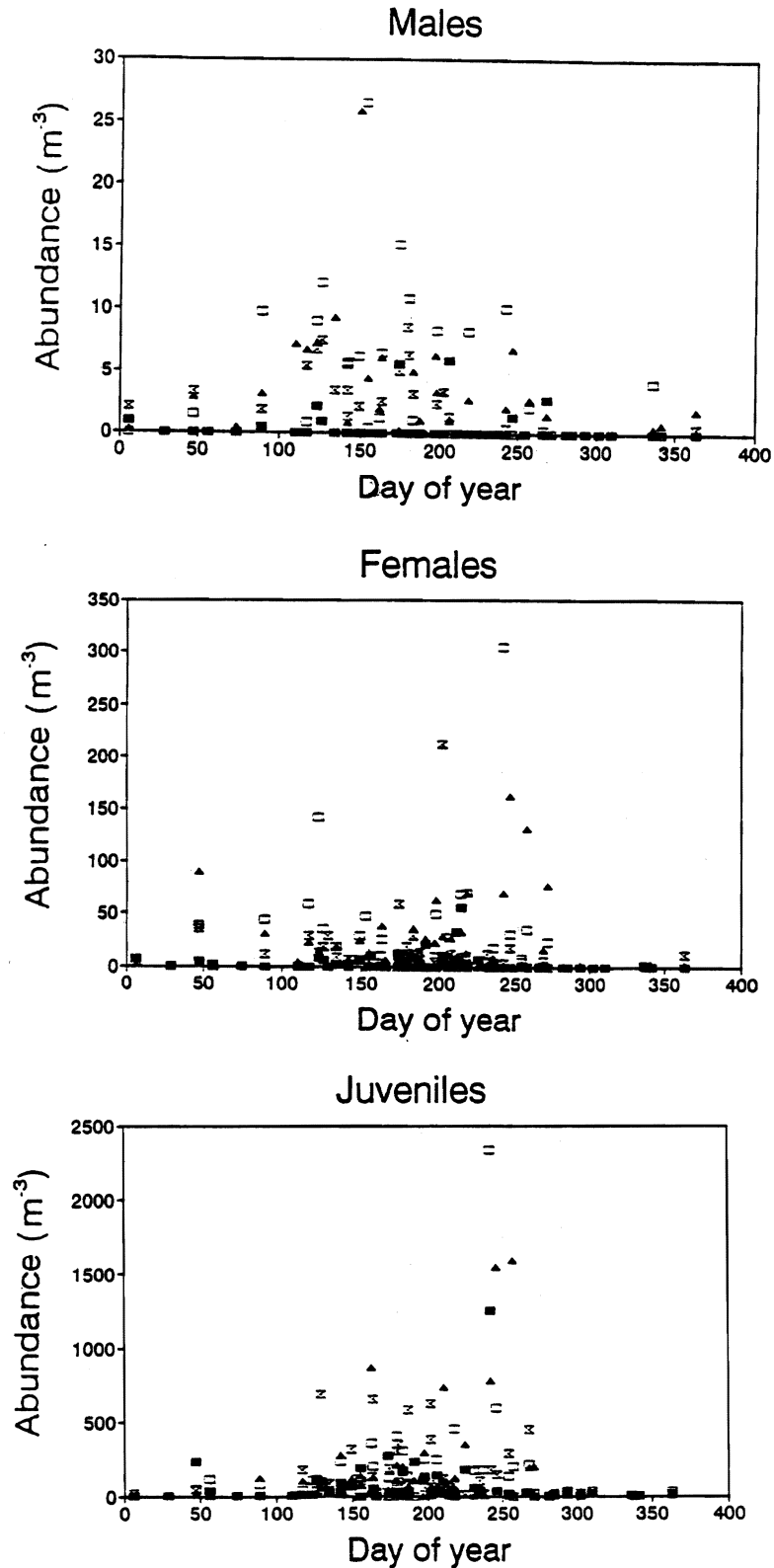

Figure 4. Seasonal cycle of abundance of *Calanus marshallae* males, females, and juveniles. This species overwinters in the autumn, from October (Day 275) until the first of the year. The population begins to increase in February reaching a peak in early September (approx. Day 250).

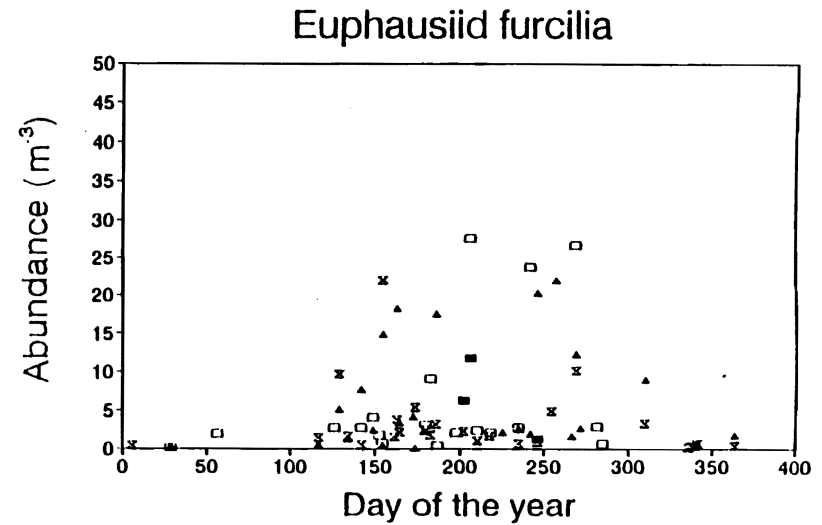
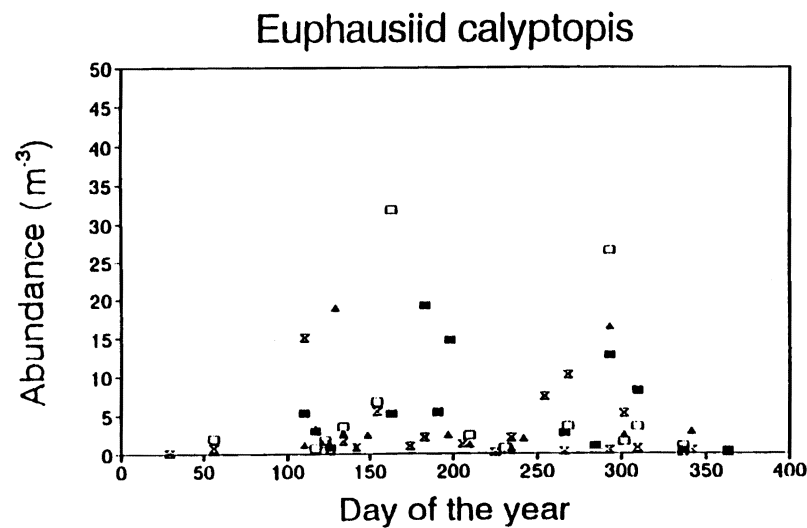
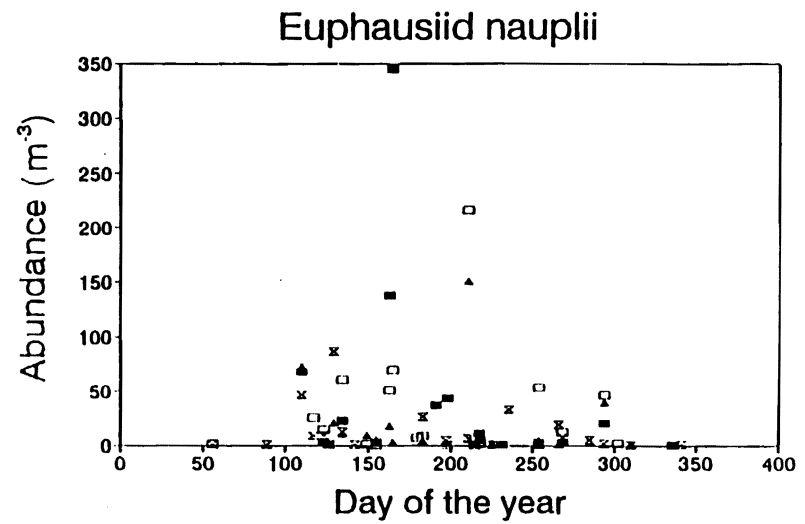
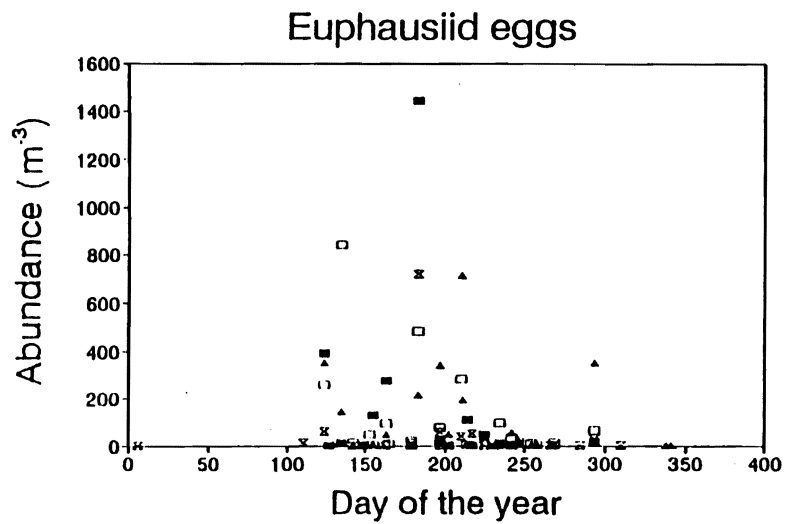

Figure 5. Seasonal cycle of abundance of eggs, larvae, and juveniles of euphausiids. Most of these data are probably for *Thysanoessa spinifera* rather than *Euphausia pacifica*, because the former is a coastal species whereas the latter is an oceanic species. Reproduction begins in early May (DAY = 120); numbers remain high throughout October (DAY 300), then decline to nearly zero through the winter and early-spring.

The coho salmon survival data can be sorted into "good" years (1969, 1970, and 1973) and "bad" years (1971, 1972, 1977, and 1978). Using total biomass of small copepods, biomass of *Calanus*, or numbers of euphausiids as indicators of ocean conditions, I conclude that 1969, 1977, and 1978 were good years for zooplankton and 1971 and 1972 were poor years. There is poor agreement between these two sets of years, so no conclusions concerning relationships between zooplankton biomass and coho survival can be reached. Also, linear regression between copepod biomass, *Calanus* biomass, or euphausiid numbers (in July/August) and coho salmon survival were not significant. Thus it is unclear how upwelling is related to ocean conditions with respect to coho salmon survival (in terms of using zooplankton abundance or biomass as a proxy for ocean conditions). However, a problem with this analysis is that coho salmon survival and zooplankton in July/August were compared. If coho salmon survival is established during the first few weeks they are at sea, then ocean conditions during the peak of the upwelling season (July/August) may be unimportant. Perhaps our attention should focus on the April/May period.

Juvenile coho salmon enter the coastal ocean in April/May. This migration is not related to the seasonal cycle of copepod abundance since the seasonal peaks in abundance of the dominant (but small) copepods (*Acartia*, *Pseudocalanus*, and *Centropages*) occur in July and August. Not surprisingly, these small copepods are not prey for juvenile coho. The coho migration may be timed to the seasonal cycles of abundance of their major prey items. For their fish prey, sand eel (*Ammodytes*) larvae are most abundant in March/April (Richardson and Percy 1977), implying that juvenile sand eels are abundant in April/May, and smelt (*osmeriid*) larvae peak in May/June, with juveniles abundant in June/July. For the larger zooplankton, the observation that euphausiid spawning commences in mid-April implies that adults are present in the water column and are available to juvenile salmonids. Also, the largest copepod which is common off the Oregon coast in spring, *Calanus marshallae*, is abundant during this April/May window. Thus I suggest that salmon migrations may be timed to the presence or abundance of their preferred prey. If we are to find meaningful correlations between prey abundance and salmon survival, direct measurements may be required of the abundance of their preferred prey in April and May.

There may, however, be a proxy variable that can serve as a correlate. I hypothesize that the oceanographic feature that is driving food-chain dynamics in April/May (and that may be related to salmon mortality) is the timing of the onset of upwelling, the so-called "spring transition." This event is correlated with the appearance of euphausiids in continental shelf waters off central California (D. G. Ainley, Point Reyes Bird Observatory, 4990 Shoreline Highway 1, Stinson Beach, CA 94970. Pers. commun., 1996), for example, and may be related to a redistribution of fish prey off Oregon since coastal circulation patterns change as upwelling is initiated. If the coho salmon migration is fixed in time, but the spring transition is variable, perhaps a classical "match-mismatch" set of events is important here. For example, if the spring transition is initiated later in the spring (e.g., in May) at the present time as compared to during the 1960s and 1970s, the coho salmon may be arriving at sea sooner than the time of greatest availability of their prey. Thus they may be encountering

"poor ocean conditions" in April that are not related to strength of upwelling, but to the timing of the onset of the upwelling season.

Conclusions

There were no clear relationships between zooplankton abundance and coho salmon survival. This was due chiefly to the fact that the peak abundance of zooplankton occurred in July/August, several months after juvenile coho salmon enter the sea. Future work on possible relations between food availability and coho salmon survival must include intense sampling in the April-May period, and must target their chief prey--sand eels, smelt, euphausiids, and larger copepods. We did learn from the study of seasonal cycles of zooplankton, that euphausiids begin to spawn in mid-April, at the time of the spring transition. Since coho salmon arrive at sea at the same time, I suggest that future retrospective analyses of coho salmon and ocean conditions should look for correlations between data of spring transition and coho salmon survival. Moreover, work on relationships between date of spring transition, the possible movement of euphausiids onto the shelf, and the possible redistribution of juvenile fish prey (sand eels and smolt) at this time might provide a partial answer to the question of what is meant by the phrase "good vs. poor ocean conditions" with respect to coho salmon.

Citations

- Brodeur, R. D. 1989. Neustonic feeding by juvenile salmonids in coastal waters of the Northeast Pacific. *Can. J. Zool.* 67:1995-2007.
- Brodeur, R. D., and W. G. Pearcy. 1990. Trophic relations of juvenile Pacific salmon off the Oregon and Washington coast. *Fish. Bull., U.S.* 88:617-636.
- Brodeur, R. D., and W. G. Pearcy. 1992. Effects of environmental variability on trophic interactions and food web structure in a pelagic upwelling ecosystem. *Mar. Ecol. Prog. Ser.* 84:101-119.
- Emmett, R. L., D. R. Miller, and T. H. Blahm. 1986. Food of juvenile chinook, *Oncorhynchus tshawytscha*, and coho, *O. kisutch*, salmon off the northern Oregon and southern Washington coasts, May-September 1980. *California Fish Game* 72(1):38-46.
- Gunsolus, R. T. 1978. The status of Oregon coho and recommendations for managing the production, harvest and escapement of wild and hatchery-reared stocks. Oregon Dep. Fish. Wildl. Processed Rep., 59 p. (Available from Oregon Dept. Fish. Wildl., P.O. Box 59, Portland, OR 97207.)

- Pearcy, W. G. 1992. Ocean ecology of North Pacific salmonids. Univ. Washington Press, Seattle, 179 p.
- Peterson, W. T., R. D. Brodeur, and W. G. Pearcy. 1982. Food habits of juvenile salmon in the Oregon coastal zone, June 1979. Fish. Bull., U.S. 80:841-851.
- Peterson, W. T., and C. B. Miller. 1975. Year-to-year variations in the planktology of the Oregon upwelling zone. Fish. Bull., U.S. 73:642-653.
- Peterson, W., and C. Miller. 1976. Zooplankton along the continental shelf off Newport, Oregon, 1969-1972: Distribution, abundance, seasonal cycle and year-to-year variations. Oregon Sea Grant Program, Oregon State Univ., Publ. ORESU-T-76-002, 111 p.
- Peterson, W. T., and C. B. Miller. 1977. Seasonal cycle of zooplankton abundance and species composition along the central Oregon coast. Fish. Bull., U.S. 75:717-724.
- Peterson, W. T., C. B. Miller, and A. Hutchinson. 1979. Zonation and maintenance of copepod populations in the Oregon upwelling zone. Deep-Sea Res. 26A:467-494.
- Richardson, S. L., and W. G. Pearcy. 1977. Coastal and oceanic fish larvae in an area of upwelling off Yaquina Bay, Oregon. Fish. Bull., U.S. 75:125-145.

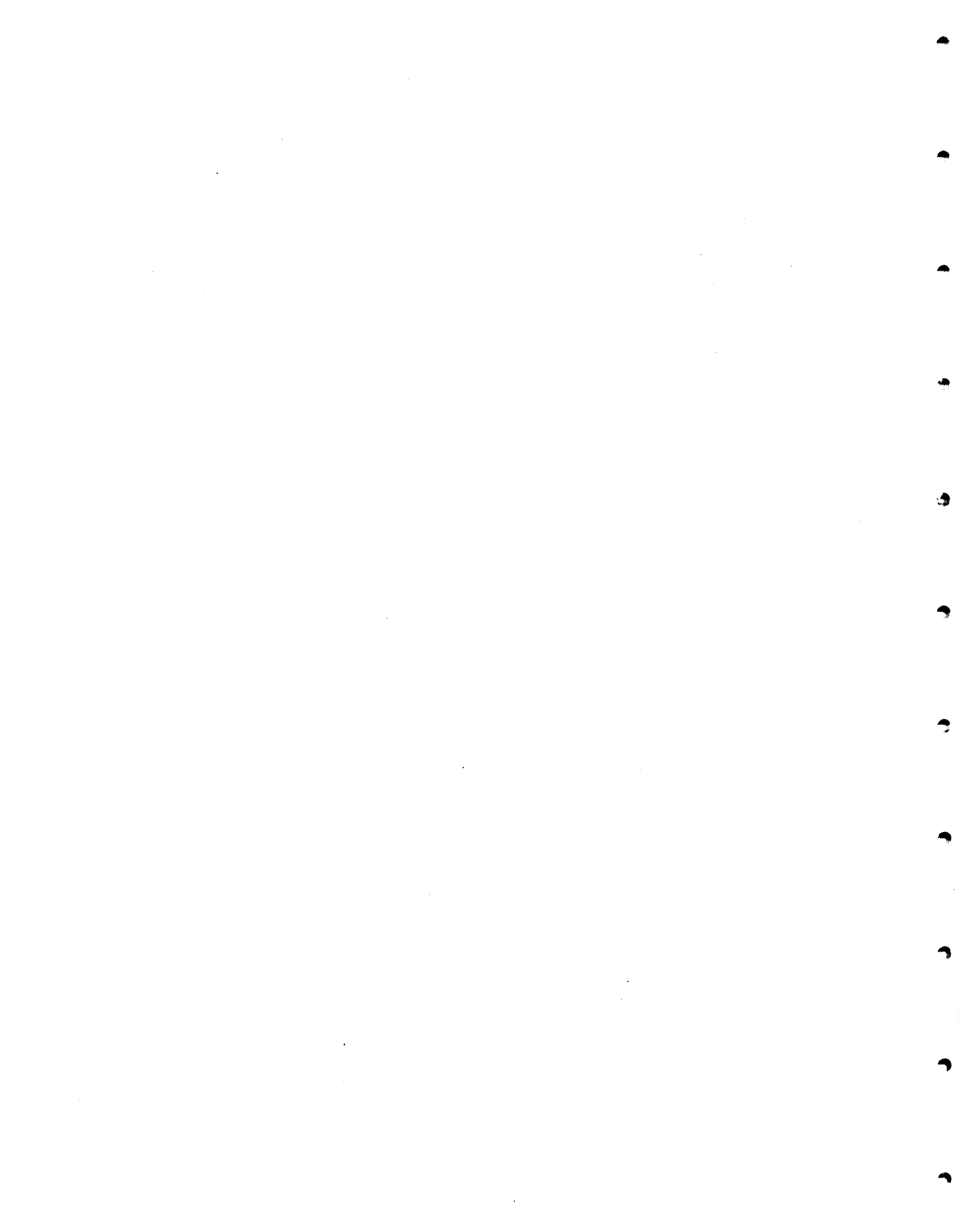

INTERANNUAL VARIABILITY IN GROWTH AND SURVIVAL
OF CHINOOK AND COHO SALMON

Peter W. Lawson

Oregon Department of Fish and Wildlife
2040 SE Marine Science Drive
Newport, OR 97365

Spring upwelling in the year of ocean entry is generally recognized as an oceanic indicator of coho salmon (*Oncorhynchus kisutch*) recruitment (Nickelson 1986, Pearcy 1992, Lawson 1993). Recent discussions (this conference) have focused on the observation that, in the Oregon Production Index (OPI) area, south of Leadbetter Point, Washington, hatchery coho salmon smolt-to-adult survival has not been correlated with upwelling in the current period of low upwelling years. Nickelson (1986) showed that in all low upwelling years between 1960 and 1981 there had been no correlation between hatchery survival and upwelling. I suggest that upwelling, by itself, is not an adequate indicator of ocean conditions. Winter sea surface temperature in the adult return year is independent of upwelling and, in combination with upwelling, can be used to explain much of the variation in recruitment of naturally spawning coho salmon in Oregon. Survival and recruitment of hatchery coho salmon, primarily from the Columbia River, are affected by freshwater factors including variability in rearing and release practices and problems with disease. These fish enter an ocean more heavily influenced by the Columbia River freshwater plume and less strongly affected by upwelling compared with the more southerly distributed Oregon coastal natural (OCN) stocks. For these reasons, it is likely that OCN and hatchery stock groups would respond differently to changes in ocean conditions. Recruitment time series, rather than survival, are used for analysis because there are no direct estimates for naturally produced smolts from Oregon over the period from 1970 to 1996.

Table 1 presents a 25-year time series of ocean population size (adult recruits to the fishery) for public hatchery and OCN coho salmon, along with spring upwelling (UW) at lat. 42°N (Bakun 1975) and winter sea surface temperature (SST) anomalies at Charleston, Oregon. Note that the OCN recruit estimates are an index which is thought to overestimate true abundances by about 50% to 80% (Jacobs and Cooney 1994). Although the numerical estimates are biased high, they capture the interannual variations in recruitment which are the subject of this analysis. The UW, SST, and hatchery and OCN recruits time series show significant correlations with year, indicating secular trends (Table 2). The signs on all trends are negative except for SST, which has been increasing. Upwelling and SST are strongly correlated with OCN recruits ($P \leq 0.0005$), less strongly with hatchery recruits ($0.07 > P > 0.002$), but not with each other ($P > 0.38$, Table 2). The lack of a significant correlation between UW and SST is unusual in ocean environmental time series and supports their use as indicators of two independent oceanic processes. Autocorrelation within time series implies that the effective number of degrees of freedom is less than the number of years in the series

Table 1. Oregon public hatchery and coastal natural coho (OCN) salmon ocean recruitment, with two environmental variables. Recruitment in thousands of fish. Sea surface temperature (SST) anomaly; deviation from mean 1971-95 January + February sea surface temperature at Charleston, Oregon, °C, upwelling (UW) anomaly; deviation from mean April + May + June Bakun upwelling index, lat. 42°N.

Return year	Hatchery recruits (t)	OCN recruits (t)	SST anomaly (t)	UW anomaly (t-1)
1971	2675.4	1362.9	-1.446	30.08
1972	1576.2	635.8	-1.396	10.08
1973	1496.0	675.1	-0.196	23.08
1974	2677.2	691.6	-0.846	47.08
1975	1313.5	671.2	-0.846	48.08
1976	3130.5	1301.0	-1.346	65.08
1977	755.0	447.4	0.304	32.08
1978	1607.3	371.4	1.304	17.08
1979	1157.5	641.4	-1.246	-2.92
1980	1059.2	348.2	0.554	17.08
1981	927.4	338.6	1.704	-1.92
1982	1199.7	314.9	-0.296	-8.92
1983	502.8	226.4	1.354	14.08
1984	646.9	274.2	0.504	-24.92
1985	656.6	303.2	-0.346	-24.92
1986	2374.3	272.4	0.354	-24.92
1987	813.4	186.9	0.504	-39.92
1988	1554.4	339.8	-0.096	-21.92
1989	1617.9	303.8	-1.196	-43.92
1990	592.9	271.4	-0.396	-21.92
1991	1780.3	243.7	-0.596	-37.92
1992	474.6	252.6	0.554	43.08
1993	225.7	236.8	0.154	7.08
1994	205.1	127.2	0.704	-50.92
1995	134.8	144.7	0.854	-3.92
1996			1.404	-1.92

Table 2. Pearson correlation coefficients ($P < > 0$) of Oregon public hatchery and Oregon coastal natural (OCN) coho salmon recruitment and two environmental variables. See also Table 1.

	Hatchery recruits (t)	OCN recruits (t)	SST anomaly (t)	UW anomaly (t-1)
Year	-0.595 (0.0017)	-0.754 (0.0001)	0.450 (0.0210)	-0.603 (0.0011)
Hatchery recruits		0.746 (0.0001)	-0.577 (0.0025)	0.369 (0.0699)
OCN recruits			-0.648 (0.0005)	0.650 (0.0004)
SST anomaly				-0.178 (0.3845)

(Kope and Botsford 1990). Employing the conservative correction described by Kope and Botsford (1990), the correlation between OCN recruits and SST remains significant ($P < 0.02$), and OCN recruits with UW is marginally significant ($0.10 > P > 0.05$).

Together, UW and SST explain most of the variability in OCN coho salmon recruitment since 1970, including years affected by El Niño. Multiple linear regression of the natural log of recruits vs. UW and SST explains about 75% of the variability in recruitment (Figs. 1-2; Table 3, Model 1). Although there is a secular trend in all three time series (Table 2), the residuals from the regression still show a secular decline. Accounting for this decline would explain an additional 16% of the variation. Upwelling and SST explain only about 27% of the variability in hatchery coho salmon recruitment, with UW not a significant factor in the regression (Table 3, Model 2).

Several factors may contribute to an apparent lack of correlation between upwelling and hatchery coho salmon recruitment (or survival) in recent years. Figure 2 compares OCN and hatchery coho recruits plotted against an index of ocean conditions calculated from the model parameters presented in Table 3, Model 1. The index is $0.011*UW - 0.365*SST$. Average ocean conditions from 1971 to 1995 receive an index of zero. All but 2 years since 1984 show below-average ocean conditions. Although recent years have shown low recruitments for OCN coho salmon, the overall pattern of increasing recruitment with improved ocean conditions is consistent across the full range of ocean conditions. Hatchery coho salmon, on the other hand, show much more variable recruitment when plotted against this index. Years prior to 1984 fit the general pattern of higher recruitment with favorable ocean conditions. However, recent years show no pattern. Considerable experimentation with hatchery rearing and release practices has been conducted in the past 15 years, complicating interpretation of these data. Winter SST seems to be much more important than UW in explaining variability in public hatchery recruitment (Tables 2-3, Model 2). Spring SST in the year of ocean entry has been identified as having high correlation with hatchery survival (T. E. Nickelson, Oregon Dep. Fish Wildl., 850 SW 15th St., Corvallis, OR 97333. Pers. commun., 1996).

Time series of average weights from ocean commercial troll fishery landings, and a condition factor based on a regression of weight vs. length, show interannual variations that may provide insights into life history processes not evident from the recruit data. Chinook salmon average weights since 1950 show a decadal fluctuation, with higher weights in the 1950s and 1970s (Fig. 3a). In contrast, coho salmon show a decline in average weight since 1950 (Fig. 3b). Both species tended to be small in size during the strong El Niños in 1957-58 and 1982-83. Scale analysis of OCN coho salmon shows no evidence of a decline in size between 1950 and 1990, so this trend may be specific to hatchery reared coho salmon (D. Bottom, Oregon Dep. Fish Wildl., 850 SW 15th St., Corvallis, OR 97333. Pers. commun., 1996.) Weight:length functions (Fig. 4) for coho salmon suggest both environmental and density-dependent factors may be operating. In years with relatively normal ocean conditions (1984, 1985, and 1986), the length:weight regressions have similar slopes. Fish were shorter and in poorer condition in 1986, when ocean populations of coho salmon in the waters off

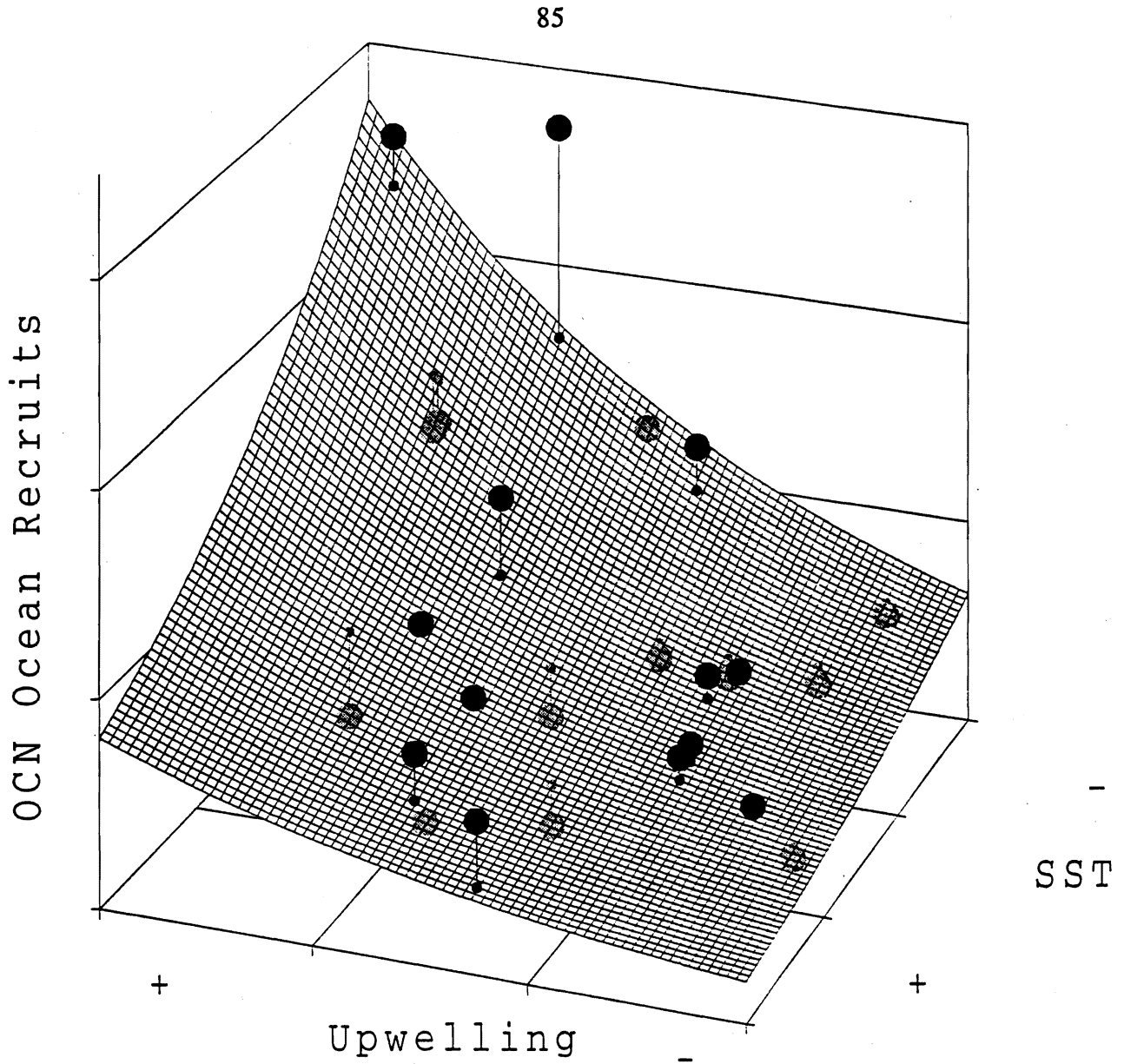

Figure 1. Modeled response surface and observed Oregon coastal natural (OCN) coho salmon recruitment, 1971-95. Model: $\text{Recruits} = 5.06 + 0.011 \cdot \text{Upwelling} - 0.37 \cdot \text{SST}$, adjusted $r^2 = 0.75$.

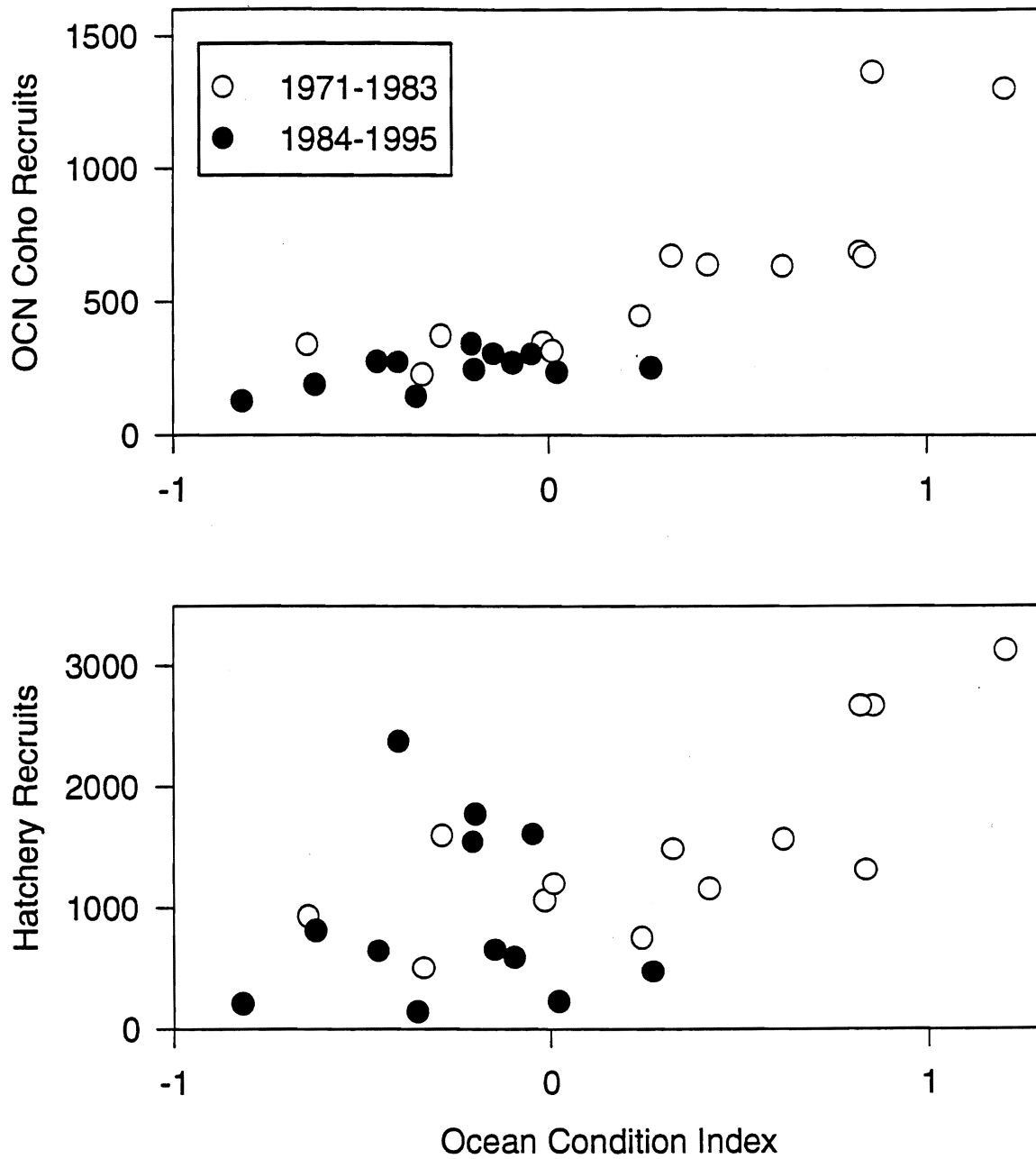

Figure 2. Ocean recruitment of Oregon coastal natural (OCN) and public hatchery origin coho salmon from 1971 to 1995, plotted against an index of ocean conditions calculated from the regression of sea surface temperature and upwelling on OCN coho salmon recruits. Recruit numbers in thousands. Open circles: 1971-83; closed circles: 1984-95.

Table 3. Regression statistics. See also Table 1.

Model 1: OCN Recruits = $a + b * UW + c * SST$
 Statistics: $F = 37.073$, $r^2 = 0.75$ $P < 0.0001$

Variable	Parameter	T	P
a	5.85	97.2	0.0001
b	0.011	5.676	0.0001
c	-0.365	-5.352	0.0001

Model 2: Hatchery Recruits = $a + b * UW + c * SST$
 Statistics: $F = 5.367$, $r^2 = 0.27$ $P = 0.0126$

Variable	Parameter	T	P
a	6.83	48.77	0.0001
b	0.0051	1.12	0.2764
c	-0.450	-1.83	0.0097

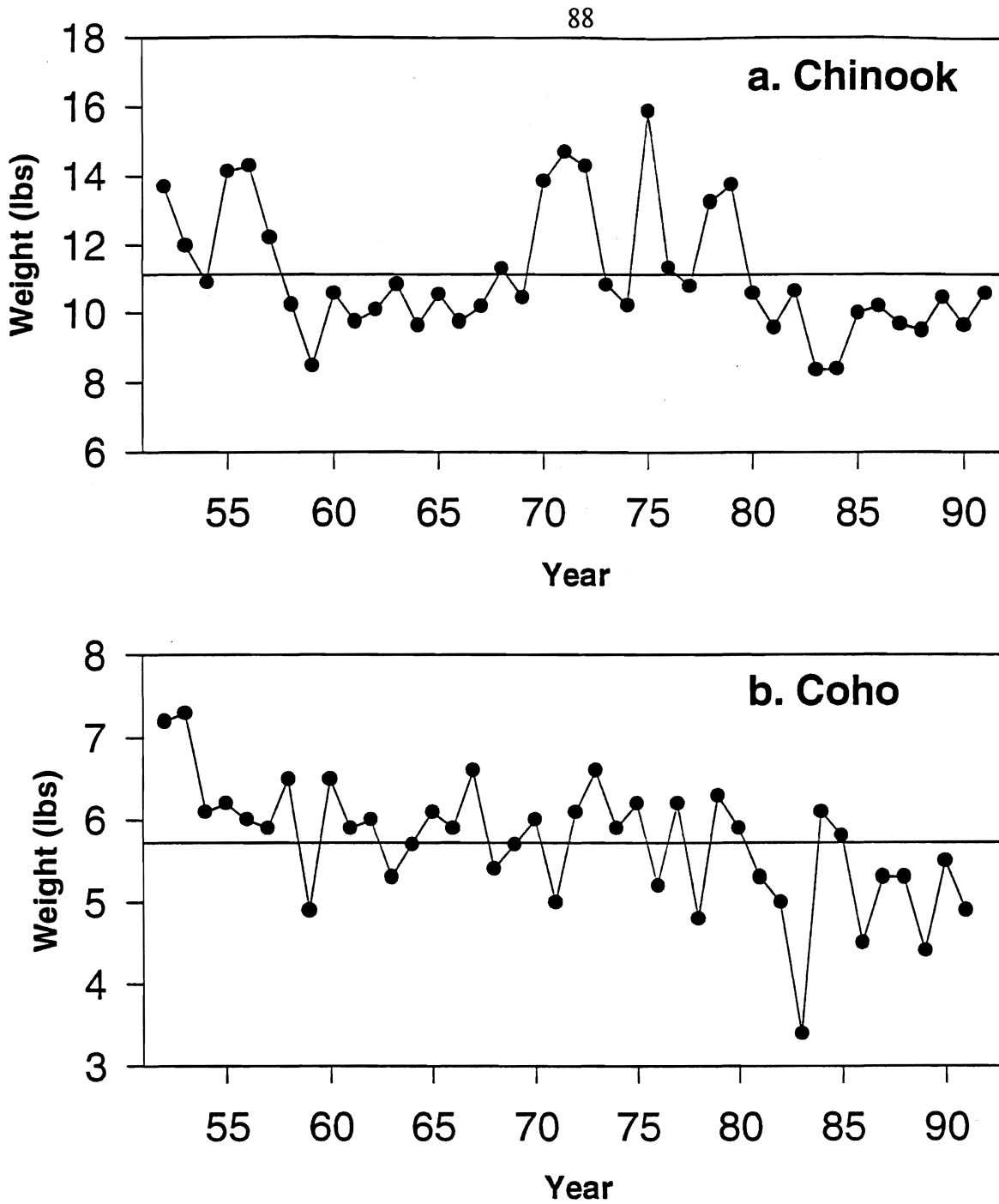

Figure 3. Average weights of chinook (a) and coho (b) salmon in the commercial troll salmon fishery off Newport, Oregon in July from 1952 to 1991. Weights are for troll-dressed fish (gutted, head on).

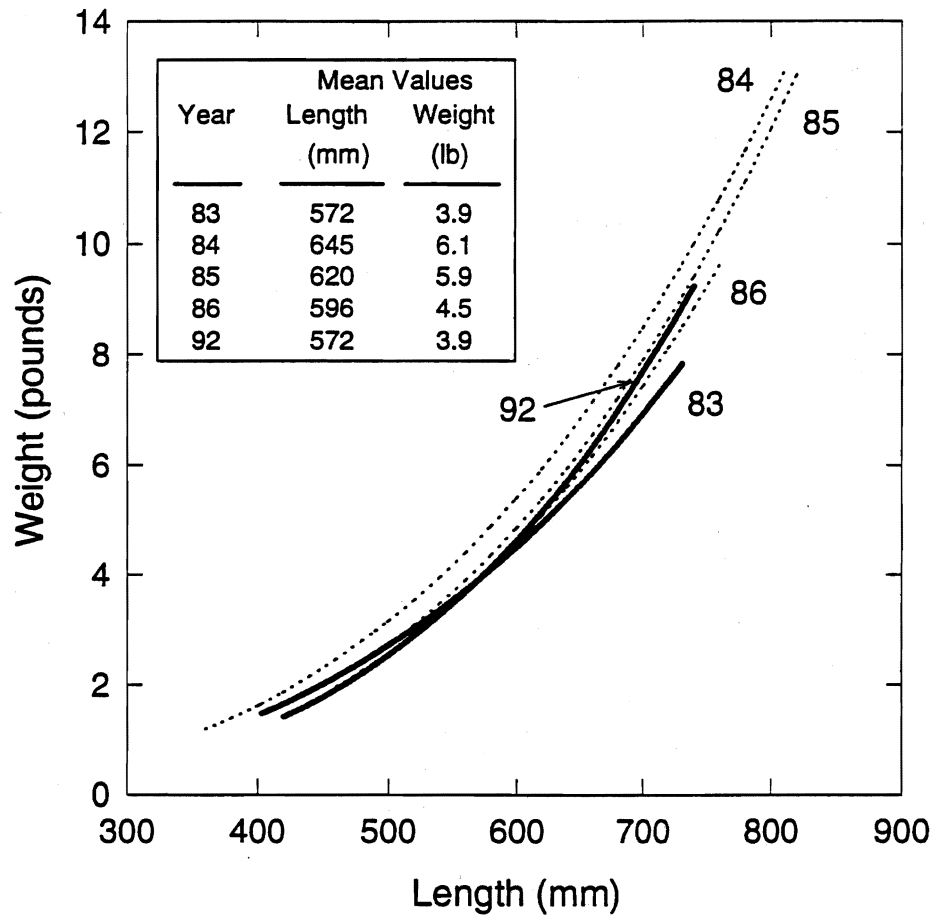

Figure 4. Length:weight relationship of coho salmon landed in Newport, Oregon for 5 years. Heavy lines indicate years affected by El Niño. Length of line reflects range of observations.

Oregon were over three times as abundant as in either 1984 or 1985, indicating that growth rates may have been reduced at high ocean densities. The 2 years of strong El Niño show the highest contrast. While mean lengths and weights were identical, and the range of sizes was similar, the slopes of the regressions diverged. In 1983, longer fish were of lower weight, while in 1992 it was the shorter fish that were low in weight. The 1982-83 El Niño was unusual, with effects reaching the Oregon coast by October 1982, compared with the 1992 event, which reached Oregon in January 1992. The length:weight function in 1992, with low abundance and poor ocean conditions, was remarkably similar to 1986, with high abundance and better ocean conditions.

Mechanisms linking UW and SST with survival and growth of coho salmon in Oregon are not well known. Pearcy (1992) presents a recent review of salmonid ocean ecology, with emphasis on coho salmon. Brodeur and Pearcy (1990) and Fisher and Pearcy (1990) investigated early oceanic life history of coho and chinook salmon from 1981 to 1985. Aside from these studies, little has been done to investigate mechanisms of survival in the ocean. Upwelling in the year of ocean entry affects the nearshore oceanic environment by increasing production, lowering temperatures, and adding spatial complexity in the form of fronts and thermal breaks (J. Barth and Smith, this volume). It may also affect the movements of predators and the availability of salmon smolts to predators. Winter SST is an index of the quality of offshore oceanic conditions, which are affected by atmospheric conditions in the central North Pacific (Norton and McLain 1994; Parrish, this volume). Sea temperatures may affect predator movements, indicate nutrient regimes, or be linked to bioenergetics of salmon and their prey. Other factors potentially contributing to trends in OCN recruitment include declines in freshwater productivity (Lawson 1993), density dependent survival (McGie 1984, Emlen et al. 1990), accumulated effects of hatchery coho salmon interactions with wild fish, and a trend since 1970 of later onset of upwelling. Future investigations should focus on discovering the links between indices of ocean conditions and the ocean life history of Pacific salmonids.

Citations

- Bakun, A. 1975. Daily and weekly upwelling indices, West Coast of North America, 1967-73. U.S. Dep. Commer., NOAA Tech. Rep. NMFS SSRF-693. 114 p.
- Brodeur, R. D., and W. G. Pearcy. 1990. Trophic relations of juvenile Pacific salmon off the Oregon and Washington coast. Fish. Bull., U.S. 88:617-636.
- Emlen, J. M., R. R. Reisenbichler, A. M. McGie, and T. E. Nickelson. 1990. Density-dependence at sea for coho salmon (*Oncorhynchus kisutch*). Can. J. Fish. Aquat. Sci. 47:1765-1772.

- Fisher, J. P., and W. G. Pearcy. 1990. Spacing of scale circuli versus growth rate in young coho salmon. *Fish. Bull.*, U.S. 88:637-643.
- Jacobs, S. E., and C. X. Cooney. 1994. Improvement of methods used to estimate the spawning escapement of Oregon coastal natural coho salmon. *Oreg. Dep. Fish Wildl. Ann. Prog. Rep.* 24 p.
- Kope, R. G., and L. W. Botsford. 1990. Determination of factors affecting recruitment of chinook salmon *Oncorhynchus tshawytscha* in central California. *Fish. Bull.*, U.S. 88:257-269.
- Lawson, P. W. 1993. Cycles in ocean productivity, trends in habitat quality, and the restoration of salmon runs in Oregon. *Fisheries* (Bethesda) 18(8):6-10.
- McGie, A. M. 1984. Commentary: Evidence for density dependence among coho salmon stocks in the Oregon Production Index area. *In* W. G. Pearcy (editor), *The influence of ocean conditions on the production of salmonids in the North Pacific*, p. 37-49. Oregon State Univ. Sea Grant, Corvallis.
- Nickelson, T. E. 1986. Influences of upwelling, ocean temperature, and smolt abundance on marine survival of coho salmon (*Oncorhynchus kisutch*) in the Oregon Production Area. *Can. J. Fish. Aquat. Sci.* 43:527-535.
- Norton, J. G., and D. R. McLain. 1994. Diagnostic patterns of seasonal and interannual temperature variation off the west coast of the United States: Local and remote large-scale forcing. *J. Geophys. Res.* 99(8):16,019-16,030.
- Pearcy, W. G. 1992. *Ocean ecology of North Pacific salmonids*. Washington Sea Grant Program, University of Washington Press, Seattle, 179 p.

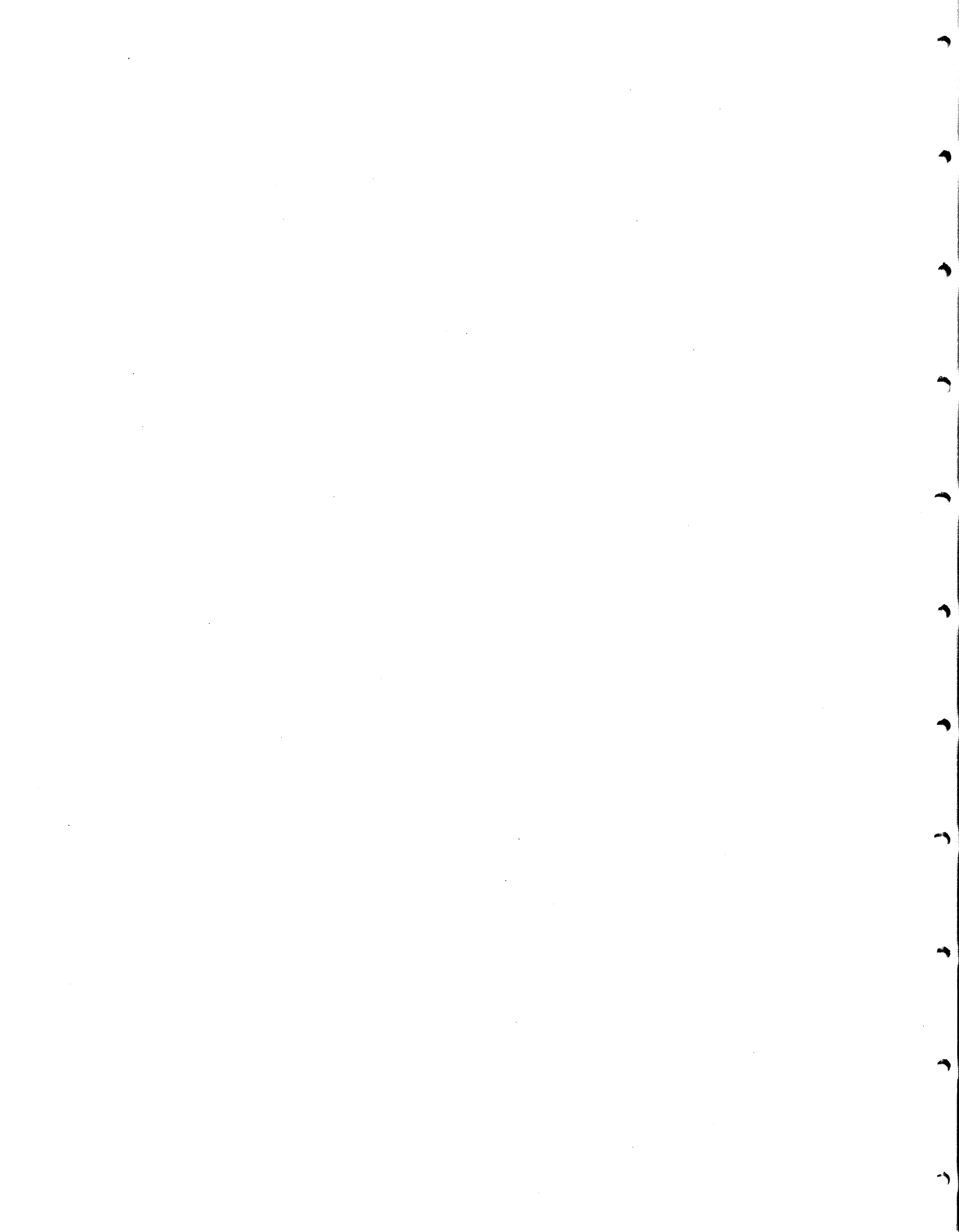

**Decadal Variations in Northeast Pacific Marine Habitats
and the Effects on Marine Survival of Salmonids**



REGIME-SCALE FLUCTUATIONS IN THE CIRCULATION OF THE NORTH PACIFIC

Richard H. Parrish

Pacific Fisheries Environmental Group
Southwest Fisheries Science Center
National Marine Fisheries Service
1352 Lighthouse Ave.
Pacific Grove, CA 93950

The first fisheries researcher to suggest that environmental changes were a controlling factor in multidecade fluctuations of fish stocks was Ljungman (1880). In his paper "Contribution Toward Solving the Question of the Secular Periodicity of the Great Herring Fisheries," Ljungman presented the known fluctuations of the Bohuslan herring fisheries from the 19th century back to the 9th century and suggested that there was about a 55-year periodicity in the abundance of herring. He further suggested that the fishery fluctuations were caused by "periodical and secular changes in the direction and intensity of the currents of the sea, by which a change in the occurrence of herring food and the consequent migrations of the large schools of herring could be explained."

There was little advancement in multidecadal-scale fisheries analyses for nearly a century; then, a number of researchers on sardines and anchovies from several major current systems came to a consensus that not only were major stocks of sardines and anchovies fluctuating on a multidecadal or "regime" time scale, but there were obvious similarities in the timing of regimes in widely separated current systems (Kawasaki and Omori 1988, Lluch-Belda et al. 1989, Lluch-Belda et al. 1992). More recent work has shown that other stocks were affected by the now well-known 1976 regime shift in the northeastern Pacific (Beamish 1993, Beamish and Bouillon 1993).

In an attempt to determine oceanic features associated with the observed biological regimes, I have used the Climate and Eastern Ocean Systems (CEOS) version of the Comprehensive Ocean-Atmosphere Data Set (COADS) (Mendelsohn and Roy in press) to develop time series and decadal difference maps for a variety of marine surface observations in an attempt to describe recent regime shifts. The widespread changes associated with the 1976 regime shift are clearly seen in the differences in decadal sea-level atmospheric pressures, surface winds, and sea-surface temperatures in the mid-latitude North Pacific.

Sea level pressure data show that the principal difference between the pre- and post-1976 decades is an intensification and eastward expansion of the winter (December-February) Aleutian low pressure system (Fig. 1). The pressure fields give the visual impression that the major change was centered around lat. 48°-55° N. From an oceanographic point of view this is misleading, since the principal oceanographic effect of the pressure field is not associated

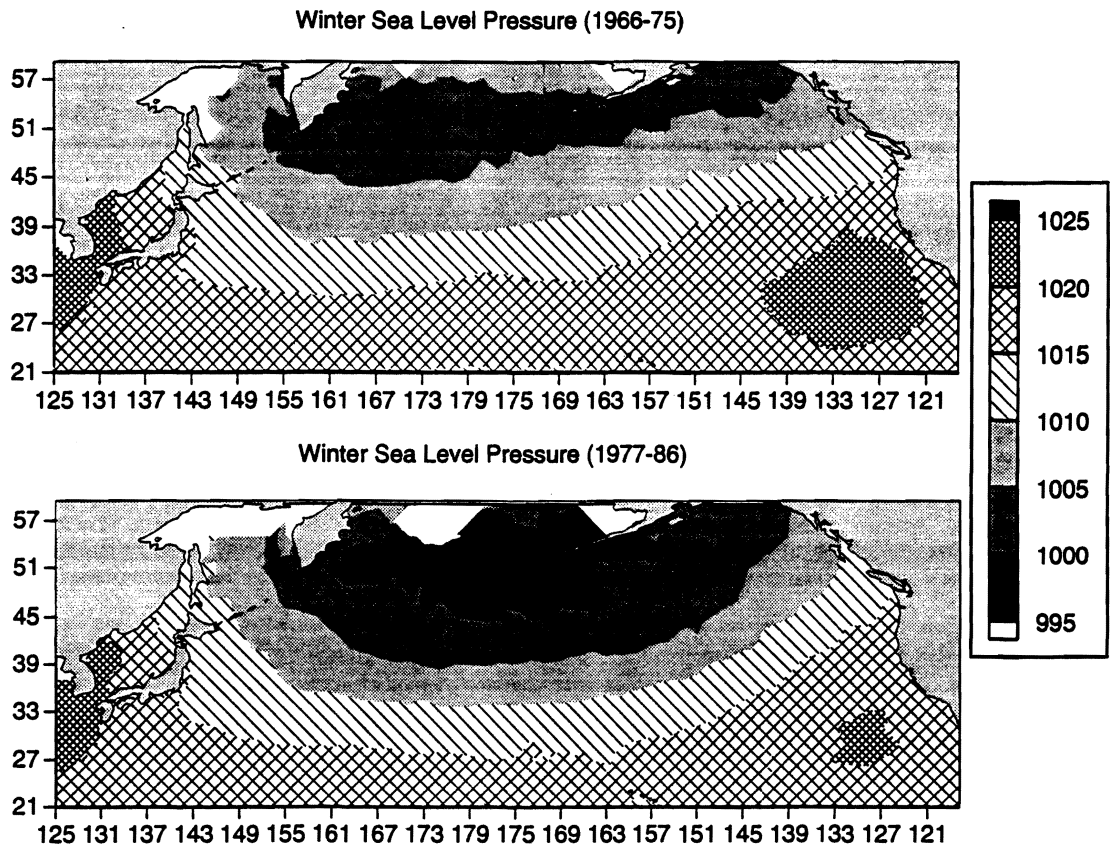

Figure 1. Mean December-February sea level atmospheric pressure (mb) by 2 degrees of latitude and longitude for the pre- and post-1976 decades.

with the position or intensity of the low but with the winds which are a function of the gradient in atmospheric pressure.

In the decade prior to 1976, the region of maximum winter winds, as seen in fields of eastward pseudostress (i.e., the means of the squares of the east component of the wind observations), was centered at about lat. 40°N and long. 160°W (Fig. 2). In contrast, in the period of 1977-86, there was a major increase in eastward pseudostress and the maxima were displaced well to the southeast. Thus, the major change was not in the vicinity of the Aleutian low pressure system but on the subtropical side of the West Wind Drift region.

The third major aspect of the regime shift is the change in sea surface temperature (SST). In winter, the eastern North Pacific was between 0.5° and 1.5°C warmer in the post-1976 decade than in the pre-1976 decade (Fig. 3). The Aleutian Islands and southern Bering Sea also had warmer winter SST in the recent decade. In contrast, the majority of the central North Pacific (i.e., lat. 20°-45°N and long. 150°E-150°W) was colder in the post-1976 decade. The maximum difference occurred in the Oyashio-Kuroshio mixing area, just west of Northern Honshu where winter SST was between 1.5° and 2°C lower during 1977-86 than during 1966-75. The winter pattern of colder SST suggests that much of the colder, subtropical side of the North Pacific Current is moved southwards in the region to the east of the dateline. In summer, the SST decadal difference pattern is somewhat different than in winter, with the colder water region displaced to the east with an extension of colder water almost to the coast off of Oregon and Washington. There is also an intensification and expansion of the warmer SST region in the Alaska Stream region. The summer temperature difference in the Oyashio-Kuroshio mixing area is considerably less than in winter.

While the sea level pressure and SST changes are relatively easy to visualize, the physical effects of the wind changes are much more complex. Wind has a number of physical effects on the sea, and these effects are different functions of the wind. For example, turbulent mixing is a function of the cube of the wind speed and is independent of wind direction, whereas Ekman transport is a function of the square of the wind vector. Divergence and convergence patterns are a function of the gradient of the wind, and geostrophic transport is a function of the wind curl or the divergence of Ekman transport. Thus, changes in the wind field alter a wide range of factors, including sea surface temperature, the depth of the upper mixed layer, upwelling, frontal formation, wind-driven currents and wind stress curl-driven currents. Polovina et al. (1995) have shown that there was a major decadal shift in winter and spring mixed layer depths and mixed layer temperatures in association with the 1976 regime shift. In particular, there was a sharp increase in mixed layer depth in a region centered at about lat. 35°N and extending from about long. 155°E to about 155°W. The geographical pattern of decadal differences in wind speed cubed, an index of turbulent mixing, is very similar to this reported increase in mixed layer depth. The region of increased mixed layer temperatures described by Polovina et al. (1995) is very similar to the area of increased SST from the COADS data (Fig. 3).

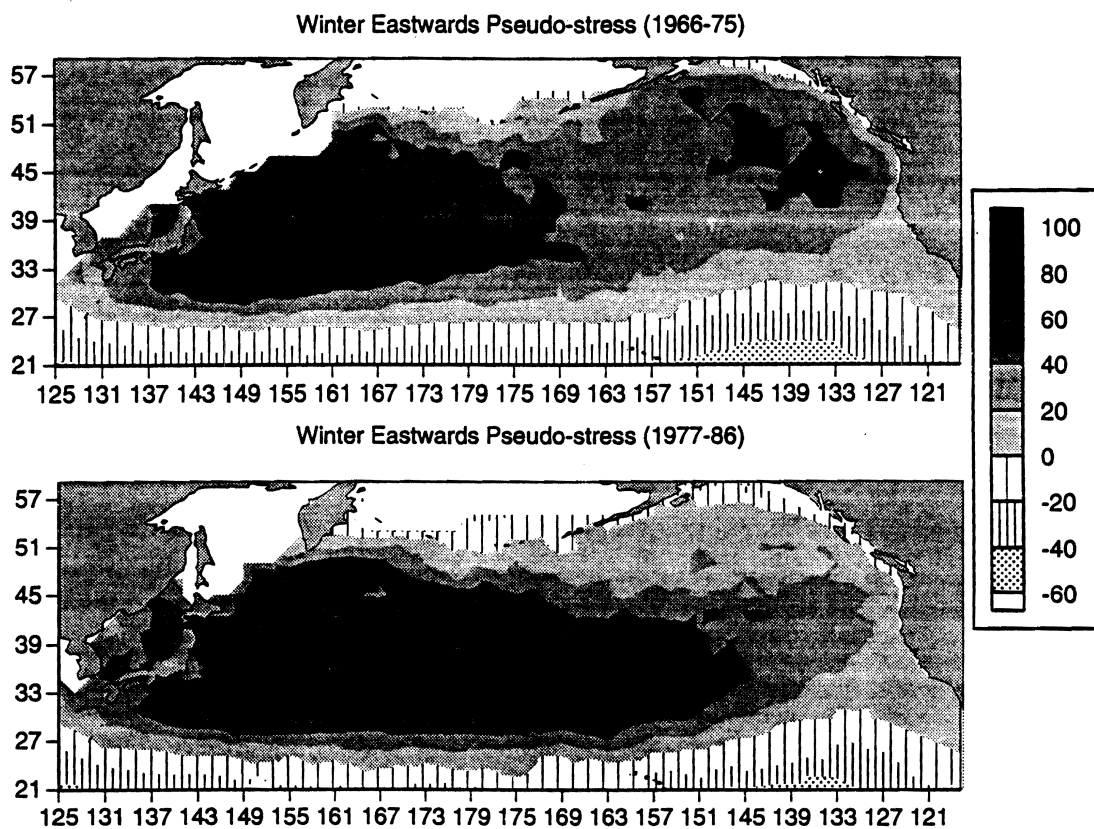

Figure 2. Mean December-February eastward pseudostress $(\text{m/sec})^2$ by 2 degrees of latitude and longitude for the pre- and post-1976 decades.

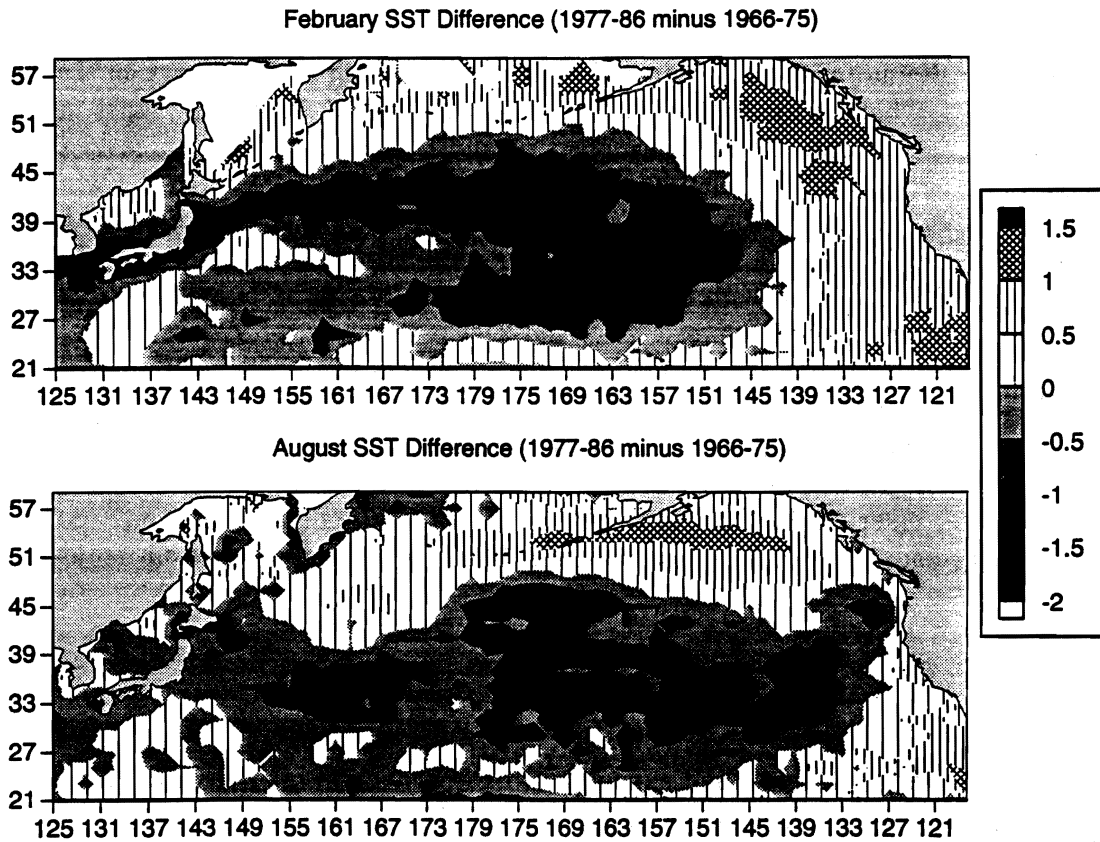

Figure 3. February and August sea surface temperature differences (degrees C) between the pre- and post-1976 decades by 2 degrees of latitude and longitude.

Although there is a distinct difference in the environmental data fields from the two decades, time series show that the regime shift occurred earlier in the northwestern Pacific than in the northeastern Pacific. Winter sea surface temperatures from the Oyashio-Kuroshio mixing region show that the shift occurred in this region in 1971, whereas the shift is generally considered to have occurred in 1976-77 in the northeastern Pacific.

The principal force altering the oceanographic conditions associated with the 1976 regime shift in the northeastern Pacific appears to be the great increase in winter eastward wind stress which was centered in the central and western North Pacific at about lat. 32-38°N (Fig. 2). This alteration in the winter winds resulted in a significant change in the surface wind-stress curl, which is the forcing function for the vertically integrated mass transport of the North Pacific Current. Decadal averages of mid-North Pacific winter, eastward pseudostress (averaged by 2° of latitude and 20° of longitude) suggest that the wind curl-driven flow of the North Pacific Current was intensified and centered at a lower latitude in the post-1976 decade (Fig. 4). In the pre-1976 decade, winter eastward pseudostress increased between lat. 57°N and 47°N, with the region between 43°N and 35°N having values near 40 (m/sec)², and then decreased between 33°N and 21°N. In the post-1976 decade, eastward stress increased to a maximum of 85 (m/sec)² at 35°N and decreased rapidly between 33°N and 21°N. In contrast, there was little difference in the divergence-convergence pattern during spring in the two decades (Fig. 5). The increase and equatorward expansion of the winter divergence pattern in the post-1976 decade would result in a lower latitude, more subtropical source for water entering the California and Alaska Currents; this, in turn, represents the probable major cause of the anomalously warm SST which occurred in both regions.

Citations

- Beamish, R. J. 1993. Climate and exceptional fish production off the west coast of North America. *Can. J. Fish. Aquat. Sci.* 50:2270-2291.
- Beamish, R. J., and D. R. Bouillon. 1993. Pacific salmon production trends in relation to climate. *Can. J. Fish. Aquat. Sci.* 50:1002-16.
- Kawasaki, T., and M. Omori. 1988. Fluctuations in the three major sardine stocks in the Pacific and the global trend in temperature. *In* T. Wyatt and M. G. Larreñeta (editors), Long-term changes marine fish populations, p. 37-53. Instituto de Investigaciones Marinas de Vigo, Vigo, Spain.
- Ljungman, A. 1880. Contribution toward solving the question of the secular periodicity of the great herring fisheries. *Rep. U.S. Fish. Comm.* 1879:497-503.

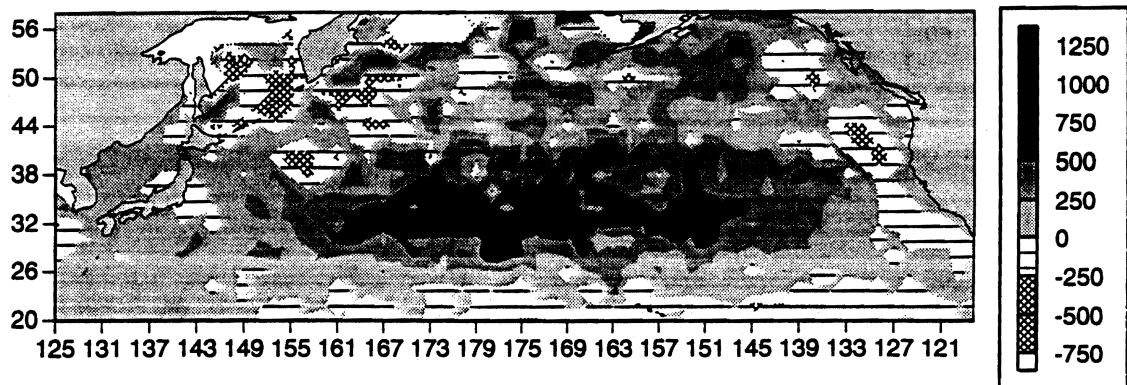

Figure 4. Winter (December-February) wind speed cubed differences $(\text{m/sec})^3$ between the pre- and post-1976 decades by 2 degrees of latitude and longitude (1977-86 minus 1966-75).

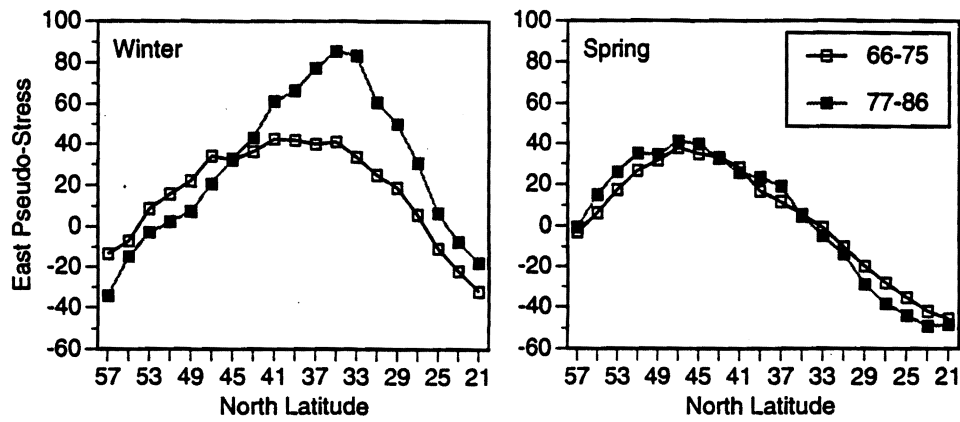

Figure 5. Winter and spring east pseudostress $(\text{m/sec})^2$ at long. 160°W - 180°W by 2 degrees of latitude.

- Lluch-Belda, D., R. J. M. Crawford, T. Kawasaki, A. D. MacCall, R. H. Parrish, R. A. Schwartzlose, and P. E. Smith. 1989. World-wide fluctuations of sardine and anchovy stocks: The regime problem. *S. Afr. J. Mar. Sci.* 8:195-205.
- Lluch-Belda, D., R. A. Schwartzlose, R. Serra, R. Parrish, T. Kawasaki, D. Hedgecock, and R. J. M. Crawford. 1992. Sardine and anchovy regime fluctuations of abundance in four regions of the world oceans: A workshop report. *Fish. Oceanogr.* 1(4):339-347.
- Mendelsohn, R., and C. Roy. In press. CODE (Comprehensive Ocean Data Extraction) Users Guide. U.S. Dep. Comm., NOAA-TM-NMFS-SWFSC-228.
- Polovina, J. J., G. T. Mitchum, and G. T. Evans. 1995. Decadal and basin-scale variation in mixed layer depth and the impact on biological production in the Central and North Pacific, 1960-88. *Deep-Sea Res.* 41(10):1701-1716.



DECADAL-SCALE ENVIRONMENTAL VARIABILITY IN THE COASTAL NORTHEASTERN PACIFIC

Franklin B. Schwing, Richard Parrish, and Roy Mendelssohn

Pacific Fisheries Environmental Group
1352 Lighthouse Avenue
Pacific Grove, CA 93950

The physical environment of the northeastern Pacific fluctuates substantially on a number of seasonal and longer scales, some periodic and predictable, and some not obviously so. El Niño Southern Oscillation (ENSO) events and other perturbations produce profound anomalies in the atmosphere and ocean on interannual to decadal and century time scales. This area also can be separated into discrete spatial regions, dominated by different physical processes that are presumably collocated with unique biological structures. The timing and intensity of large-scale climate events may not be coherent between regions. The boundaries defining these regions may change over time as well. Our objective is to describe decadal-scale differences in the spatial texture of the northeastern Pacific, to provide a base from which to evaluate the effect of climate change on the area's ecosystems, and particularly on its salmonid populations and fisheries.

The data analyzed in this paper are summarized from the Comprehensive Ocean-Atmosphere Data Set (COADS). Monthly time series for 1946-90 were constructed from COADS sea surface temperature (SST) and wind stress data for 2° latitude boxes along the U.S. West Coast. A nonlinear trend was estimated for the monthly series using a state-space model (Schwing and Mendelssohn in press). The 2° averaged data from the entire North Pacific Ocean also are meaned seasonally for two decade-long periods (1966-75 and 1977-86) to compare seasonal differences before and after a significant "climate shift" in 1976 (Trenberth 1990). This analysis places the coastal time series in a basin-scale context.

Based on the monthly time series, the U.S. West Coast can be divided into three distinct geographical regions. The northern region (north of 40°N) features a rapid transition from strongly equatorward to poleward wind stress with distance north (Fig. 1). The mean stress north of 44°N is poleward and has become increasingly poleward over time. The SSTs north of 40°N vary temporally in unison and exhibit little spatial difference in magnitude (Fig. 2).

Winds south of 40°N are equatorward and can be described in terms of central and southern regions (Fig. 1). The central region (32-40°N) exhibits the greatest coastal wind stress magnitudes. This region features the greatest scales of interannual-to-decadal variation in stress (Fig. 1) and SST (Fig. 2) as well. Stress in the southern region (22-32°N) has become increasingly equatorward over time, like the central region, but with relatively little interannual variation (Fig. 1). Mean SST (Fig. 2) decreases consistently with increasing

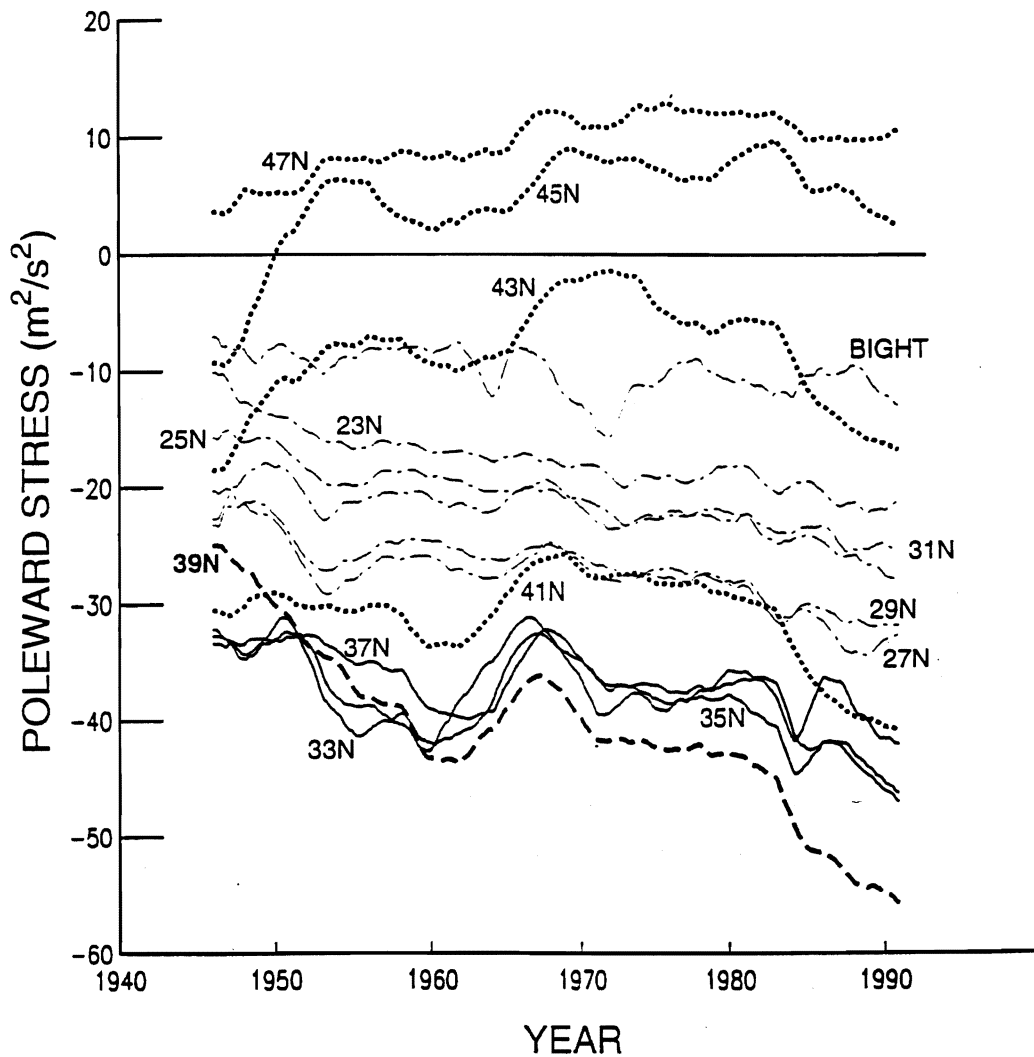

Figure 1. Time series of poleward wind stress trends for Comprehensive Ocean-Atmosphere Data Set (COADS) 2° boxes. Values denote center latitude of COADS boxes. Dashed-dotted lines represent time series from southern region (22-32°N). Solid lines represent time series from central region (32-40°N). Bold dotted lines represent time series from northern region (40-48°N). Bold dashed line represents 38-40°N time series.

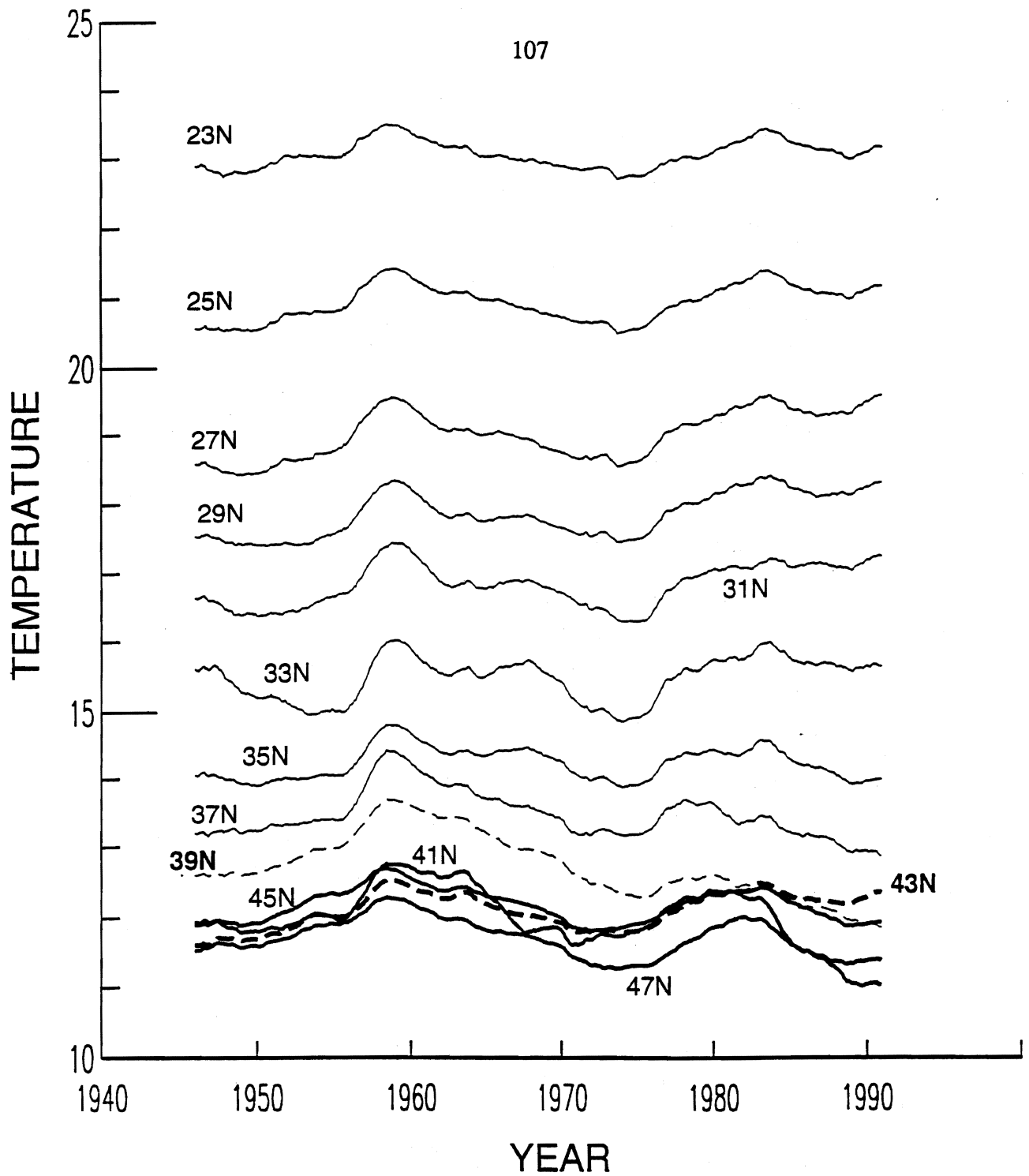

Figure 2. Time series of sea surface temperature (SST) trends for Comprehensive Ocean-Atmosphere Data Set (COADS) 2° boxes. Values denote center latitude of COADS boxes. Fine lines denote time series south of 40°N. Bold lines denote time series north of 40°N. Fine and bold broken lines denote time series for 38-40°N and 42-44°N COADS boxes, respectively.

latitude in the central and southern regions. The SST over about 30-38°N appears to warm rapidly in response to the 1957 and 1983 ENSO events as well as the 1976 regime shift (Trenberth 1990).

The SSTs off Washington and Oregon, on the other hand, take several months to years following the 1976 shift to warm by similar amounts, and they are less sensitive to ENSO events. Although SST series exhibit a warming tendency south of 36°N, the COADS SSTs show a cooling tendency north of 36°N (Fig. 2). However, shore-based SST trends along the entire U.S. West Coast display a significant warming tendency over the past several decades. A lack of correspondence between the COADS and shore SST time series north of 36° N suggests there is considerable cross-shelf as well as latitudinal variability in the northeastern Pacific. This is confirmed by analysis of the decadal differences before and after 1976 for the North Pacific, as well as examination of COADS data in the northeastern Pacific on 1° space scales (Schwing et al. in press).

The SST shows decadal-scale periods of warming and cooling that extend along the entire coast. Wind stress anomalies are less coherent latitudinally and are uncorrelated with local SST, suggesting that decadal-scale SST variability in the coastal northeastern Pacific is controlled by the basin- to global-scale meteorological fields, rather than local wind forcing. The decadal comparison of data over the entire basin substantiates this conclusion.

Figure 3 shows the linear trends of the poleward stress and SST time series. The correlation between poleward stress and SST is positive in much of the central region; increasing equatorward stress coincides with a cooling trend. Outside of the central region, however, the trends in stress and SST are negatively correlated. Increasing equatorward stress coincides with warming south of 34°N, while greater poleward stress accompanies a cooling trend north of 44°N.

It is apparent that over the last several decades, surface coastal waters in the northern portion of the California Current have either experienced a different set of forcing conditions from those farther south, or have responded differently to large-scale atmospheric forcing. Not only are the tendencies of wind and SST different in these regions, but the different linear relationships between stress and SST imply that the primary mechanisms driving variability in SST, and probably the general ocean circulation, on decadal time scales is fundamentally different in these regions.

Preliminary analysis of decadal changes beginning in 1976 shows a strong correlation between anomalously high wind divergence, hence greater upwelling, and cool SST in winter over the central North Pacific. Anomalously weak divergence and warm SSTs are seen in a broad stretch along the North American west coast. Cool anomalies propagate eastward until they extend along the West Wind Drift to within a few degrees of the coast off Oregon and Washington. Thus, it appears that wintertime anomalies in wind forcing over the central Pacific, rather than changes in coastal wind, lead to the observed regional SST pattern in the coastal northeastern Pacific. A complex interaction of spatially as well as temporally varying

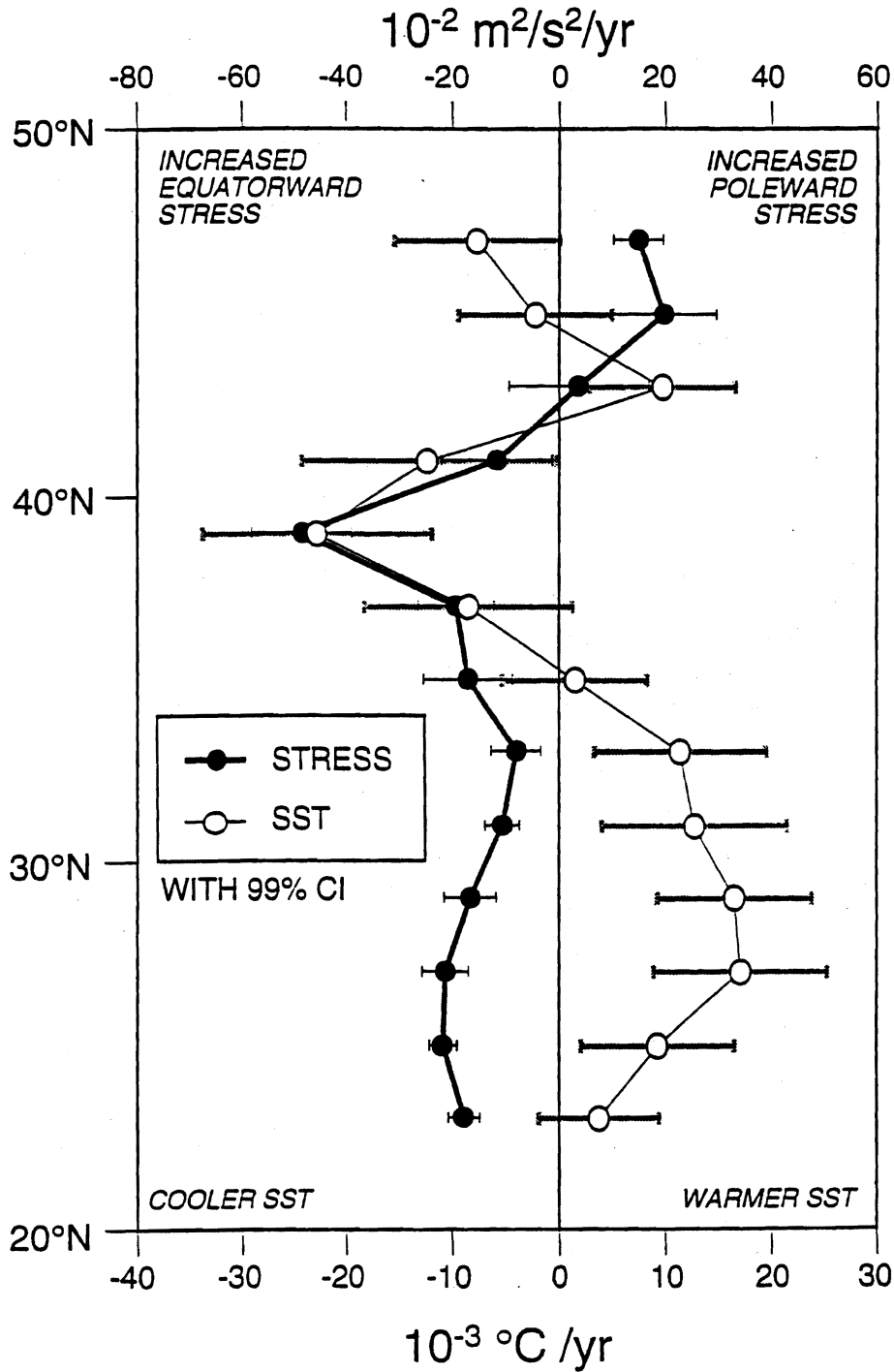

Figure 3. Linear trends of Comprehensive Ocean-Atmosphere Data Set (COADS) poleward stress (solid circles) and sea surface temperature (SST) (open circles) time series along North American west coast, 22-48°N. 99% confidence intervals shown by vertical bars (gray for stress, black for SST).

Ekman transport, wind mixing, and direct heating appears to be responsible for the long-term fluctuations in SST.

The temporal and spatial variability of the physical environment of the northeastern Pacific must be considered when analyzing changes in the biological structure of its ecosystems. Roemmich and McGowan (1995) have found that zooplankton biomass off southern California has decreased by 80% since the 1950s. Over a similar period, Brodeur and Ware (1992) detected a doubling in zooplankton biomass in the Gulf of Alaska. The results reported here show that regional differences in environmental variability have existed in the northeastern Pacific over the last five decades; therefore, it is conceivable that analogous differences in biological productivity, coupled with environmental variability, have occurred as well.

The results presented here clearly demonstrate the highly variable nature of the northeastern Pacific environment in time and space, and they argue against assuming climate change is constant, or that it can be represented by a record from a single location. The distinct latitudinal regionalization and cross-shelf variability of wind and SST fields has key implications for ecosystem studies as well as fisheries management. For example, which time series or regions are more important to study in terms of defining a salmon stock's ocean environment? Regional differences also mean that, over their life history, salmon face a spatially heterogeneous, changing climate. Widespread stocks also may display a very different long-term variability from species whose domain is limited to one of the homogeneous regions described here. Fisheries scientists must evaluate the relative environmental differences in each region as they pertain to the climate signal and its variability, and compare them to a species' distribution and behavior as a function of its life stage in order to fully understand the consequences of climate change on populations.

The long-term trends described here cannot be described without considering changes in seasonal patterns. Schwing and Mendelssohn (in press) demonstrated, with state-space models, that long-term changes in the seasonal cycle of environmental time series can be independent from interannual-to-interdecadal fluctuations. The results presented here demonstrate the importance of evaluating the entire spectrum of temporal and spatial variability, rather than simply at global climate scales, when examining long-term environmental fluctuations. This will improve our understanding of the linkages between long-term variations in atmospheric forcing and the coastal ocean's response to this variability on regional scales, and ultimately improve our assessment of how climate variability impacts marine ecosystems and living marine resources.

Citations

Brodeur, R. D., and D. M. Ware. 1992. Long-term variability in zooplankton biomass in the subarctic Pacific Ocean. *Fish. Oceanogr.* 1:32-38.

Roemmich, D., and J. McGowan. 1995. Climatic warming and the decline of zooplankton in the California Current. *Science* 267:1324-1326.

Schwing, F. B., and R. Mendelssohn. In press. Increased coastal upwelling in the California Current System. *J. Geophys. Res.*

Schwing, F. B., R. Mendelssohn, and R. H. Parrish. In press. Recent trends in the spatial variability of the SST and wind fields of the California Current System. Committee on Earth Observations Satellites (CEOS) Workshop Proceedings.

Trenberth, K. E. 1990. Recent observed interdecadal climate changes in the Northern Hemisphere. *Bull. Am. Meteorol. Soc.* 71:988-993.



REGIME SCALE CLIMATE FORCING OF SALMON POPULATIONS IN THE NORTHEAST PACIFIC--SOME NEW THOUGHTS AND FINDINGS

R. C. Francis¹ and S. R. Hare²

¹School of Fisheries
Box 357980
University of Washington
Seattle, WA 98195-7980

²International Pacific Halibut Commission
P.O. Box 95009
University of Washington
Seattle, WA 98145-2009

Recent work (Hare and Francis 1992, Francis and Hare 1994, Hare and Francis 1995, Hare 1996) has shown that Alaska salmon population production responds to regime-scale (interdecadal) climate forcing, manifesting itself in low frequency and rather abrupt jumps (Fig. 1) which correspond very closely to similar abrupt shifts in North Pacific atmosphere and ocean climate (Fig. 2). Careful analysis reveals that

1. This connection between atmosphere/ocean physics and salmon production occurs early in the salmon marine life history.
2. To date, connections between indices of climatic variability and salmon production have been found at the regime (interdecadal) scale, but not at the interannual scale.

The signature of these climatic regime shifts is reflected in a number of atmospheric and oceanic variables, the most noteworthy of which are winter sea level pressure (SLP) and spring sea surface temperature (SST) over a large region of the North Pacific. During the 20th century, there appear to have been four interdecadal regimes (Fig. 2, top) in the coupled atmosphere/ocean system of the North Pacific: 1900-24, 1925-46, 1947-76, 1977-present (Francis et al. in prep., Hare 1996). The lower two panels of Figure 2 show differences in mean winter SLP and SST between the two most recent regimes. These two patterns characterize what we call the Pacific Decadal Oscillation which, when positive, is reflected in a deep winter Aleutian low pressure system and a bipolar SST anomaly pattern with warm SST anomalies along the Northeast Pacific coast and cold SST anomalies in the central Pacific. These patterns are derived, analyzed, and discussed in detail by Hare (1996).

The objective of this paper is to discuss recent findings on the effects of regime-scale climate changes on upper ocean dynamics and apparent responses in phytoplankton and zooplankton production in both the California and Alaska Current regions of the Northeast

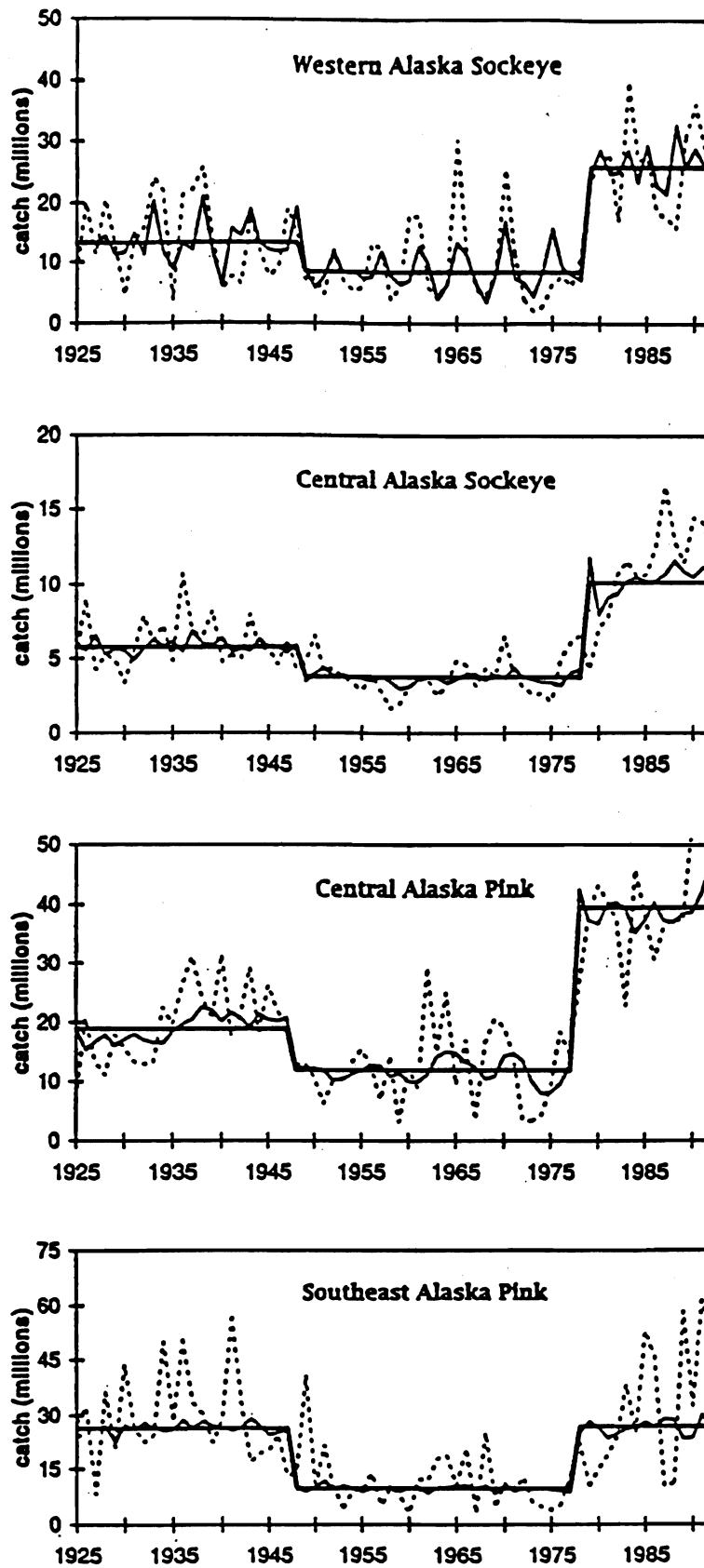
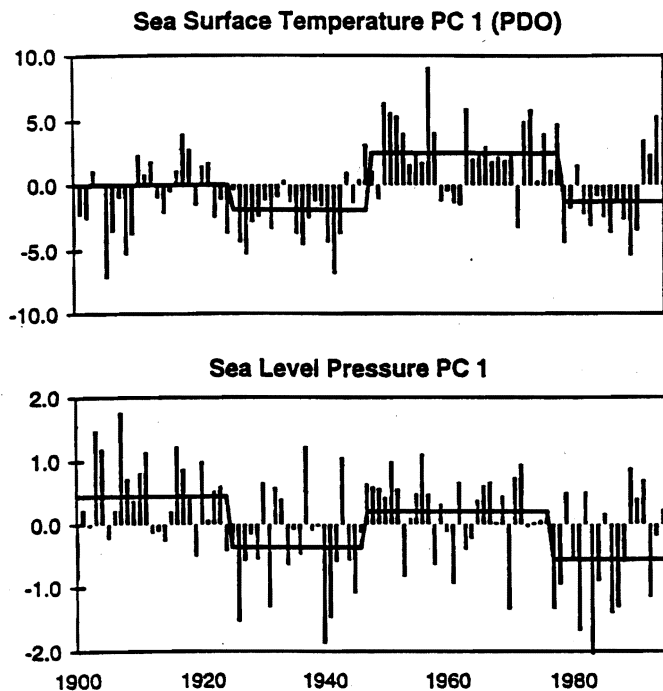

Figure 1. Time history (dashed lines), intervention model fits (thin solid lines), and estimated interventions (thick solid lines) for Alaska salmon time series (from Francis and Hare 1994).



Differences in Mean SLP and SST between 1947-76 and 1977-92

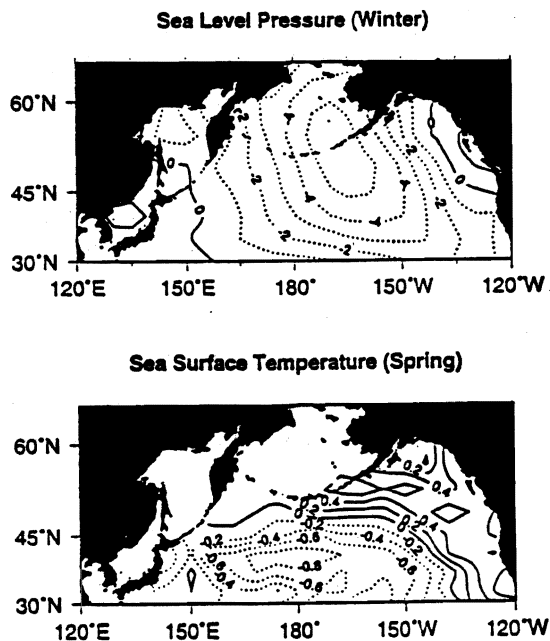

Figure 2. Two indicators of large-scale, long-term climate variability over the North Pacific in the 20th century. The top two panels show major components of variability of North Pacific winter sea surface temperature (SST) (Pacific Decadal Oscillation, PDO) and winter sea level pressure (SLP) along with intervention model fits. The two bottom panels illustrate winter atmospheric and spring oceanic effects of the 1976/77 climate regime shift (Hare 1996).

Pacific. These results have major implications concerning mechanisms linking the observed decadal-scale climate response of Northeast Pacific salmon to their ocean environment.

Recent Findings

A Model

Over the past few decades, a conceptual model has developed which relates atmospheric circulation in the North Pacific to variations in biological production in the large oceanic ecosystems (Fig. 3) of the Northeast Pacific (Ware and MacFarlane 1989). Wickett (1967), Chelton and Davis (1982), and Chelton (1984) were the first to speculate that the intensities of the flows in the Alaska and California Currents fluctuate in opposition to each other. That is, when one of the currents is stronger than normal, the other is weaker. They hypothesized that these north-south shifts in the bifurcation of the Subarctic Current (West Wind Drift) could be forced by physical factors occurring in the western or central Pacific. Taking this one step further, and based on marine biological indices, Hollowed and Wooster (1992) and Francis (1993) have characterized two alternating interdecadal states of atmospheric and oceanic circulation in the Northeast Pacific which result in very different components of fisheries production (e.g., groundfish, salmon) in these two major coastal domains. Hollowed and Wooster (1992) have characterized two alternating "warm" and "cool" states lasting 6 to 12 years each. Hare and Francis (1992), Francis (1993), Francis and Hare (1994), and Hare and Francis (1995) find similar although longer periods (25 to 35 years) of oscillating "warm" and "cool" regimes which relate very closely to the production dynamics of Alaska salmon (Figs. 1-2). In addition, Francis (1993) speculated that the interdecadal dynamics of salmon production in these two oceanic domains is inversely correlated.

How has this model fared or changed in recent years? In what follows, we present both biological and physical results which expand and change our understanding of how interdecadal climate change affects the dynamics of marine biological production in the Northeast Pacific.

Biology

Perhaps the major breakthroughs in terms of changing our thinking have related to studies of phytoplankton and zooplankton production in the Northeast Pacific and their responses to interdecadal climate forcing. The three major studies reported in this section (Brodeur and Ware 1992, Polovina et al. 1995, Roemmich and McGowan 1995) focused on changes in plankton production which occurred in response to the Northeast Pacific climatic regime shift of 1976-77 (Miller et al. 1994).

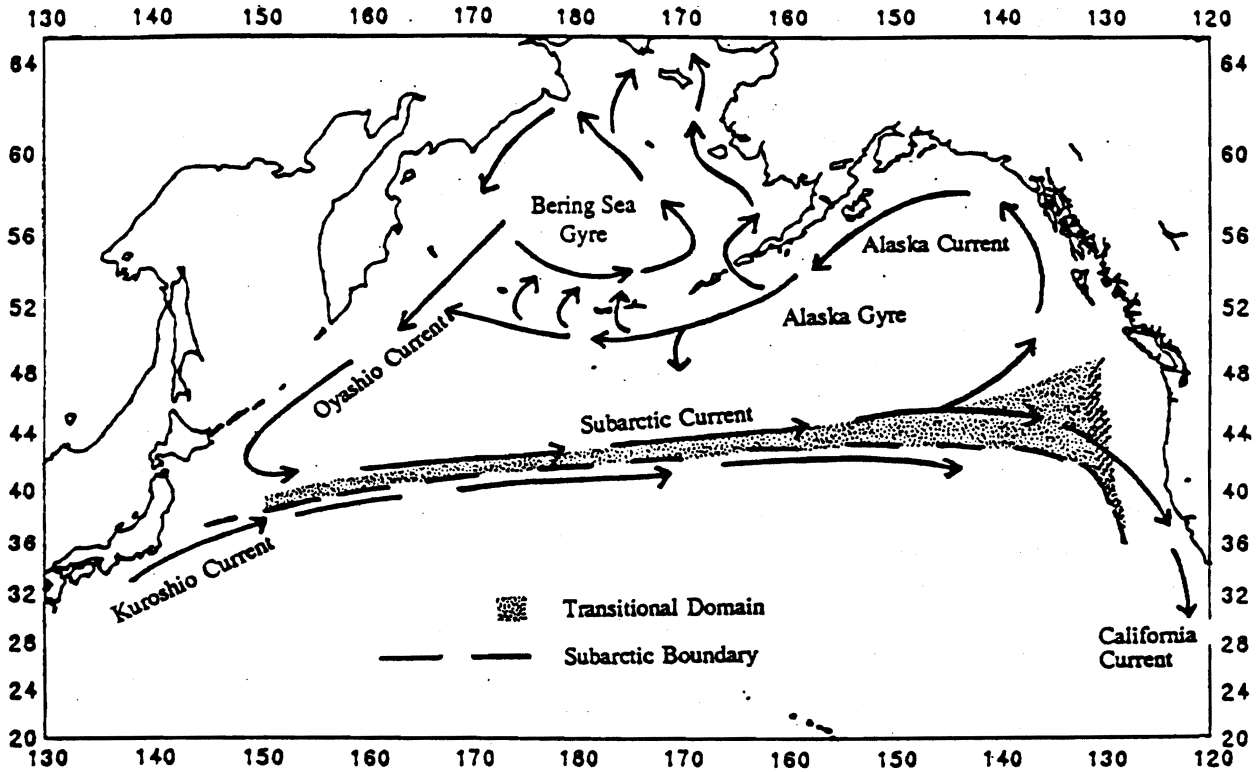

Figure 3. Relevant large-scale upper-level physical oceanography of the Subarctic North Pacific and Bering Sea (Francis and Hare 1994).

Venrick et al. (1987) showed significant shifts in phytoplankton production (integrated chlorophyll *a*) just north of Hawaii at about the time of the 1976-77 regime shift (Fig. 4). Subsequent analysis (Venrick 1994) revealed that his response was due to increased phytoplankton production in deep water (75-200 m) in response to a shift in ocean mixing and a deepening of the mixed layer. Polovina et al. (1995) further supported this and reported, associated with the 1976-77 regime shift and intensification of the Aleutian low pressure system, a 30-80% deepening of the winter and spring mixed layer in the Subtropical Domain (Northwestern Hawaiian Islands) and central Transition Zone (Emperor Seamounts) and a 20-30% shoaling of the mixed layer in the northern Subarctic Domain (Gulf of Alaska) (Fig. 5). Based on modeling of phytoplankton response to these changes, Polovina et al. (1995) speculated that these physical conditions would increase primary and secondary production in the northern Subtropical and northern (central) Subarctic Domains and decrease them in the Transition Zone.

Brodeur and Ware (1992), Brodeur et al. (1996), and Roemmich and McGowan (1995) have shown that zooplankton production in the central Subarctic Domain (central Gulf of Alaska) and Coastal Upwelling Domain (California Current) seems to have responded in opposite directions to the 1976-77 regime shift. In the central Subarctic Domain, summer zooplankton biomass more than doubled between the late 1950s and the 1980s (Brodeur and Ware 1992, Brodeur et al. 1996, Fig. 6). The mechanism proposed to underlie the interpretation of these phenomena involves variation in the circulation of the Subarctic Gyre in the Northeast Pacific--a speeding up and slowing down of the Subarctic and Alaska Currents. This would affect both Ekman pumping at the center of the gyre, leading to increased upwelling and divergence in the center, and advection (transport of nutrients, phytoplankton, zooplankton) around the circumference of the gyre. Associated with this would be a shoaling of the euphotic zone (mixed layer depth) and a resultant increase in the exposure of phytoplankton cells to light.

On the other hand, in the southern Coastal Upwelling Domain, the biomass of macrozooplankton has decreased by as much as 70% between the early 1950s and the early 1990s (Roemmich and McGowan 1995, Fig. 7). The authors provide several mechanistic hypotheses for their observations. First, they suggest that the coastal warming associated with the 1976-77 regime shift may have caused increased stratification in the California Current, a sharper thermocline with less vertical displacement of nutrient-rich waters due to wind stress (coastal upwelling), and a resultant decrease in the fraction of the year when wind stress is strong enough to lift nutrient-bearing waters to the sea surface near the coast. Second, they speculate that a climate-induced shift in ocean circulation, such as the bifurcation of the west wind drift (Subarctic Current), might import warmer water into the California Current, thus decreasing the supply of either nutrients or the volume of zooplankton carried by the California Current.

Both of these findings are consistent with the earlier results of Wickett (1967) who studied the interannual variation in zooplankton volumes off California, in the western Bering Sea, and at Ocean Station P (lat. 50°N, long. 145°W) in the central Gulf of Alaska during the

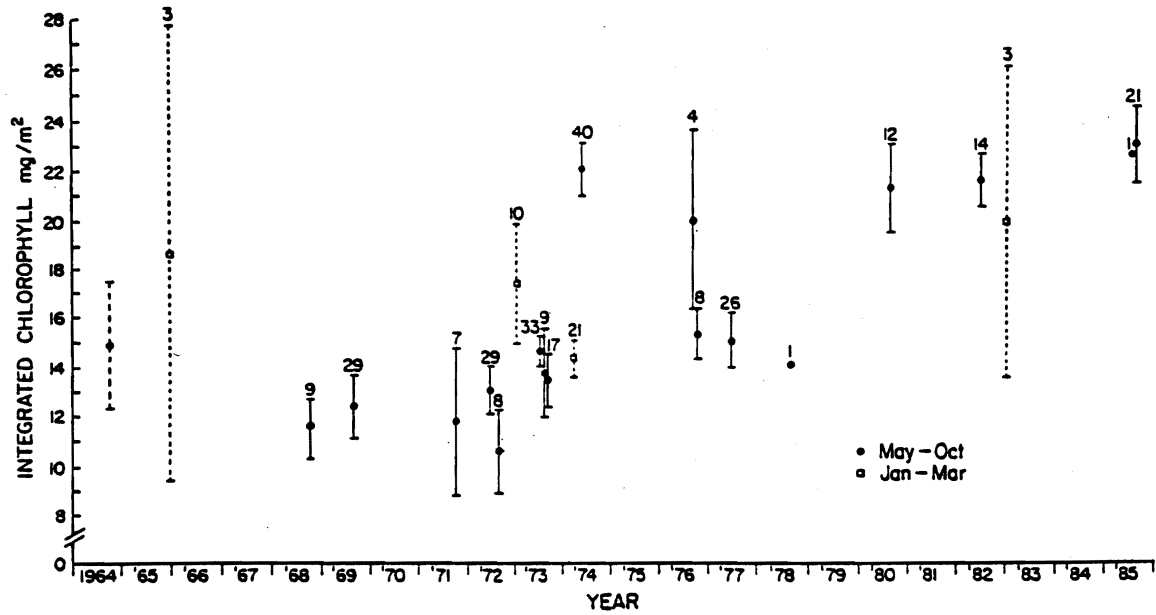

Figure 4. Index of phytoplankton production in the central North Pacific (observations of integrated chlorophyll *a*). Bars indicate the 95% confidence intervals of the mean; the number of observations is shown above each bar. Winter values (open squares) and values before 1968 are excluded from the analysis (Venrick et al. 1987).

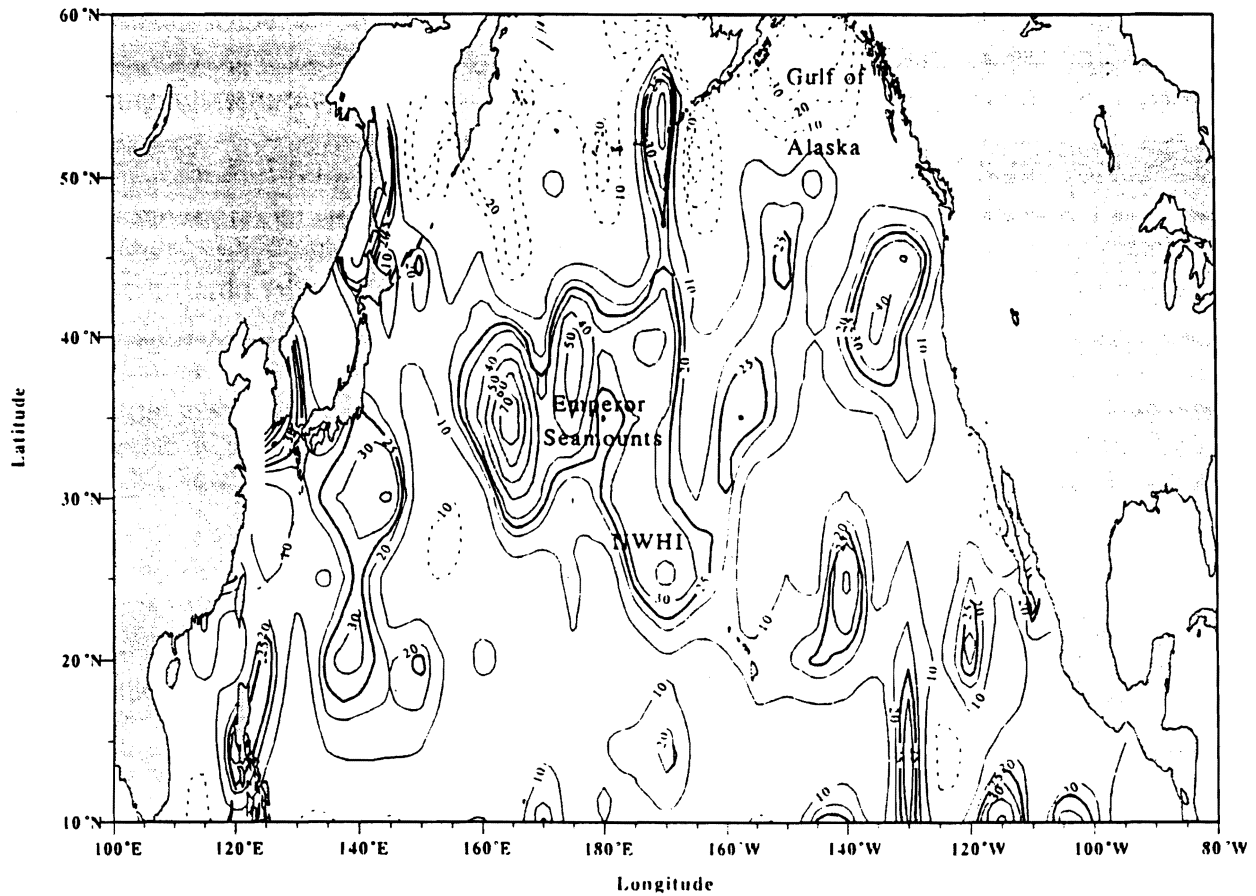

Figure 5. Percent change in mean winter and spring mixed layer depth (MLD) between 1977-88 and 1960-76 relative to 1960-76 levels. Shading for 1977-88 MLD which are more than 25% deeper than 1960-76 MLD. Dashed contours are negative values (Polovina et al. 1995).

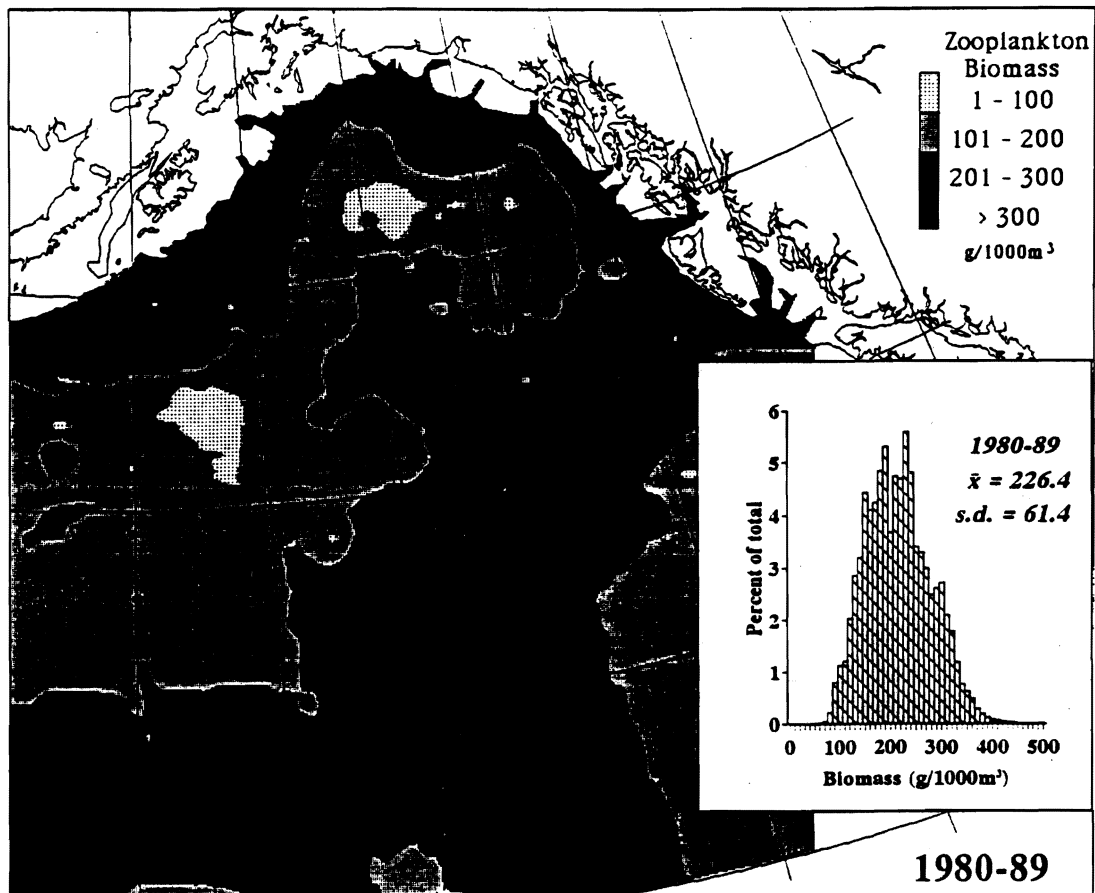
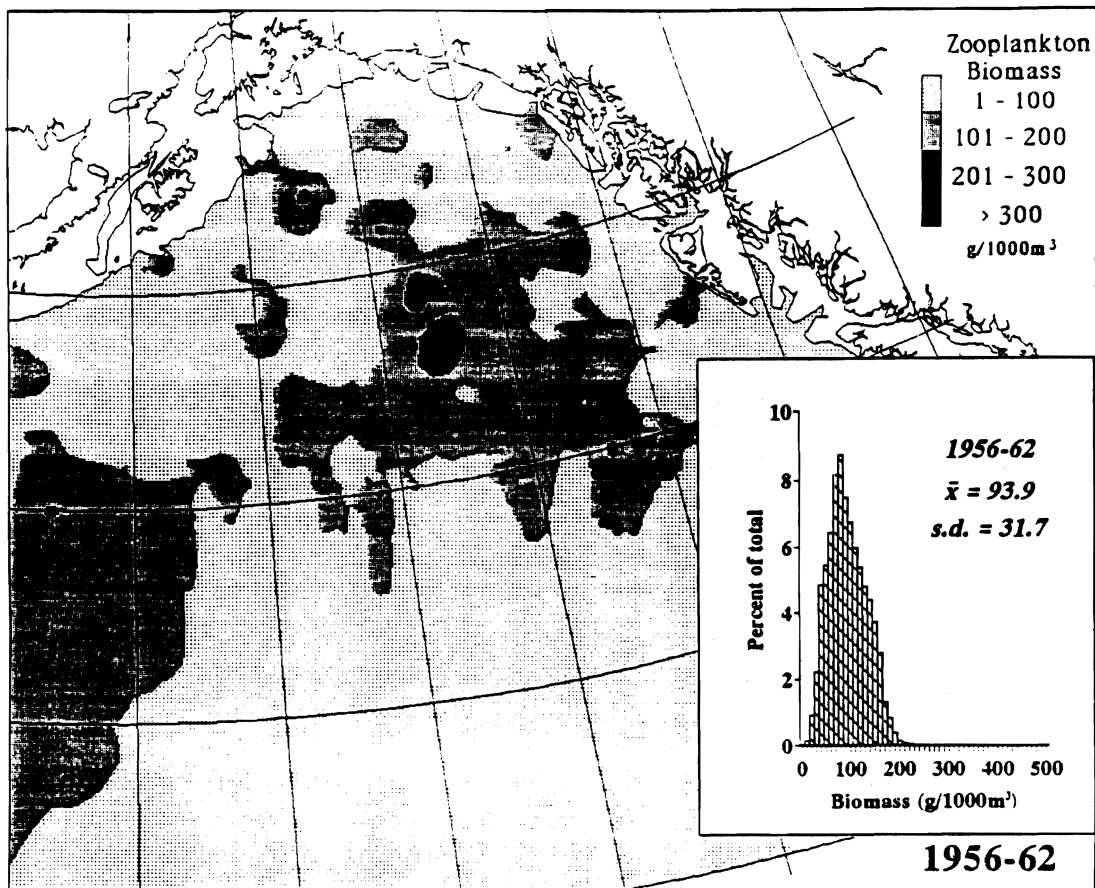

Figure 6. Large-scale distribution of zooplankton biomass from sampling during the 6-week period beginning June 1 for the period 1956-62 (top) and 1980-89 (bottom) (Brodeur et al. 1996).

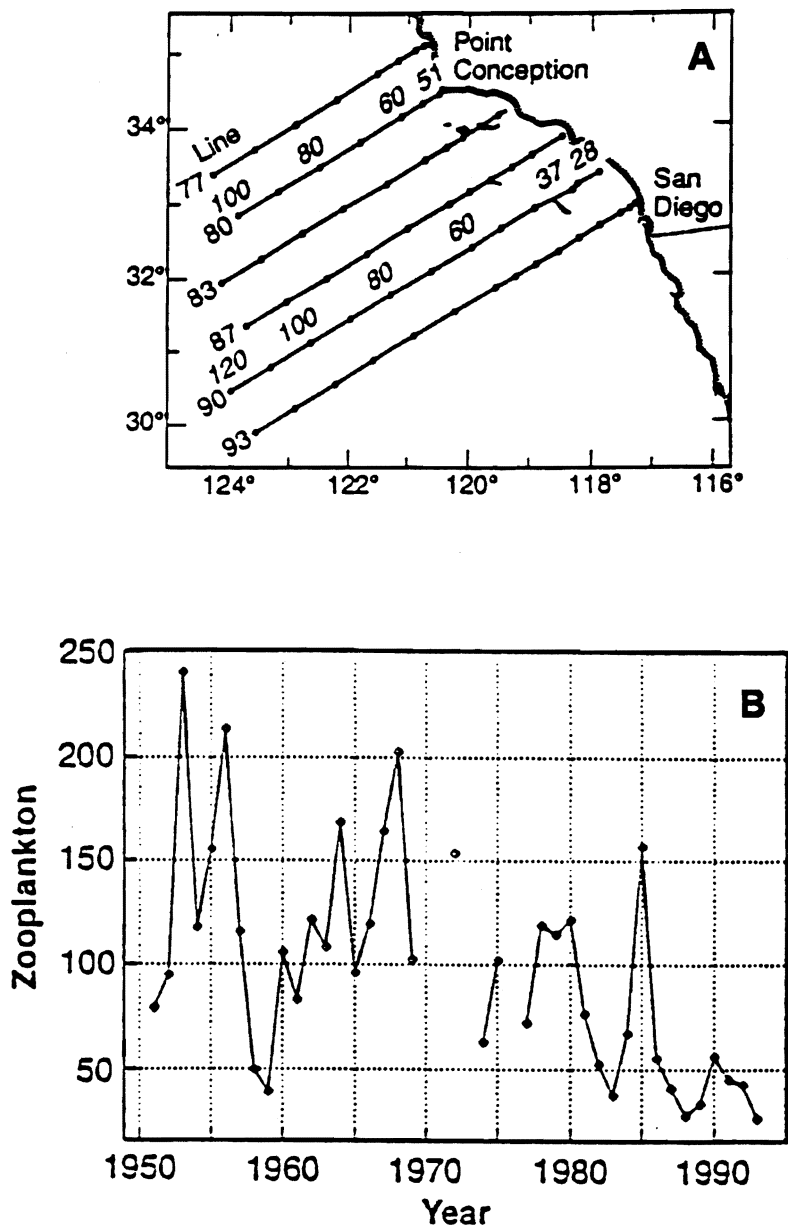

Figure 7. California Cooperative Oceanic Fisheries Investigations Line 90 (A) and corrected annual averages of zooplankton volume (B) since 1950 (Roemmich and McGowan 1995).

1950s and early 1960s. By studying the relative abundances of zooplankton in these regions and relating them to zonal and meridional components of surface winds in a region upstream of the bifurcation of the Subarctic Current, Wickett found that a major cause of zooplankton variation downstream from the division point (bifurcation of the Subarctic Current into the California and Alaska Currents) is the change in the proportion of surface-layer, wind-driven water (Ekman transport) that is swept southward (escaping) out of the subarctic circulation. The implication is that zooplankton and nutrients are carried with the surface waters and that forcing conditions (surface winds) which favor a high "escapement" of subarctic water into the California Current will increase zooplankton production in that region and decrease it in the region of the Alaska Current.

Physics

Although there is indirect biological evidence for the ocean circulation models first proposed by Hollowed and Wooster (1992) and Francis (1993), the physical evidence is very hard to come by. Five recent papers do, however, begin to shed light on the issue and speculate considerable modification to the above model. Tabata (1991), in reexamining the Chelton and Davis (1982) premise, found a correlation between the coastal component of the Alaska Current and California sea level, particularly during El Niño years. He attributed this correlation, however, to the coastal currents being in phase from Canada to California rather than to changes in the bifurcation of the Subarctic Current. Kelly et al. (1993) analyzed sea-surface height anomalies for the Northeast Pacific over a 2.5-year period. Their results tended to support those of Chelton and Davis (1982) that the California and Alaska Current systems fluctuate "out of phase," coinciding with variations in wind-stress curl in the North Pacific and subsequent diversion of flow from the Alaska Gyre into the California Current as well as with some aspects of El Niño Southern Oscillation (ENSO) dynamics. Van Scoy and Druffel (1993), in an analysis of tritium (^3H) concentrations in seawater from Ocean Station P and a station in the southern California Current, suggested increased advection of subpolar water into the California Current during non-El Niño years and that ventilation of the Alaska Gyre (intensification) occurs during El Niño years. Lagerloef (1995), in his analysis of dynamic topography in the Alaska Gyre during 1968-90, suggested that after the well-documented climatic regime shift of the late 1970s, the Alaska Gyre was centered more to the east and its circulation appeared weaker after the shift than before. The implication is that the intensification of the winter Aleutian low pressure system associated with the regime shift did not result in a spinup of the Alaska Gyre. Finally, Miller (1996) reviews some recent advances in large-scale modeling of the California Current and its interaction with basin-scale circulation and forcing. He reports the significant deepening of the thermocline off California after the 1976-77 regime shift (similar to Roemmich and McGowan 1995) and attributes this to basin-scale changes in wind-stress curl. This is achieved at two time scales--the first at the decadal and North Pacific Gyre scale forced by significant deepening and weakening of the Aleutian low pressure system, and the second at the interannual ENSO scale forced by waves propagating through the ocean from the tropics.

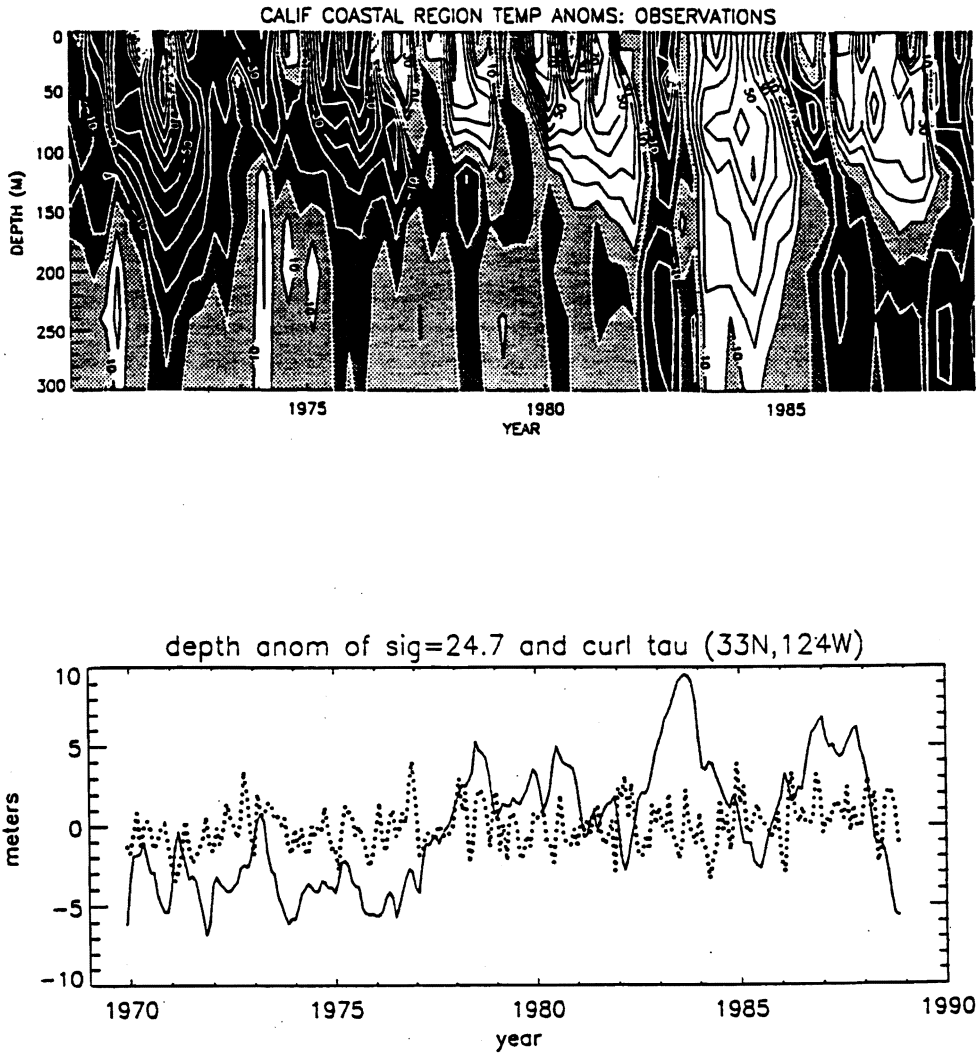

Figure 8. Top: Observed temperature anomalies averaged over the region long. 130-120°W, lat. 25-45°N from the surface to 300-m depth from 1970-88. Contour interval is 0.1°C with darker shades cooler and lighter shades warmer. Bottom: Depth anomalies (solid) of model isopycnal layer ($\sigma_{\theta} = 24.7$) at a grid point off the California coast. Positive anomalies indicate a deeper thermocline at mean depth of roughly 180 m. Local wind-stress curl anomalies (dotted) at the same point (Miller et al. 1996).

Miller et al. (1996) and Miller (1996) support the findings of Roemmich and McGowan (1995) and report both decadal and interannual signals in the dynamics of the thermocline off the California coast (Fig. 8). The first signal is a thermocline deepening associated with decadal-scale changes in the subtropical gyre and its mixed layer structure as influenced by changes in gyre-scale wind forcing (wind-stress curl). The second signal occurs at the ENSO time scale (3-7 years) and is driven by waves propagating through the ocean, presumably from the tropics. One can see the effects of both of these processes in the dynamics of mixed layer temperature profiles as well as thermocline depth anomalies (Fig. 8). The results of Enfield and Allen (1980) tend to support this and indicate that the region off central California (San Francisco) may be a dividing point between locations to the south where sea level is influenced by anomalies of equatorial origin (related to fluctuations in the Southern Oscillation) and locations to the north where sea level is influenced strongly by local wind-stress anomalies resulting from energetic winter storms (related to the winter Aleutian low pressure phenomenon). Therefore, the higher frequency dynamics in mixed layer depth and temperature reported by Miller et al. (1996) and Miller (1996) for a region off southern California (Fig. 8) may not be as evident in more northerly components of the California Current. In fact, Freeland (1990) reported that coastal British Columbia sea surface temperatures showed very little coherence with the ENSO signal.

Finally, Miller (1996) also reported that after the 1976-77 regime shift there appeared to be a stronger than normal northward flow into the central Gulf of Alaska but little change in (flow into) the California Current system.

Discussion

Clearly much has been learned since 1982 (when Chelton first proposed his model) concerning the relation between atmosphere/ocean physics and Northeast Pacific salmon production. Based on the results summarized above, the following seems fairly clear:

1. The major climate influence on salmon production occurs at the decadal time scale, early in the marine life history, and in a bottom-up fashion through physical influences on primary and secondary production.
2. Plankton production seems to be influenced at the decadal (regime) scale by major climate-induced changes in the structure of the mixed layer. These influences appear to operate in opposite directions in the California Current and Alaska Current oceanic domains.
3. The farther south, the stronger is the influence of climate on biological production at the higher-frequency ENSO scale. For example, the coastwide spike in Pacific Northwest salmon production which seemed to affect cohorts entering the ocean either in late 1984 or early 1985 could have resulted from a 1985 rebound to the

1982-83 El Niño (Fig. 8--rapid cooling of the ocean and corresponding deepening of the mixed layer off California in 1985).

4. The effects of ocean circulation, particularly as they relate to the relative intensities of advection of subarctic water into the California and Alaska Currents, are less clear. Recent evidence points to a more complicated picture than the first speculated by Chelton (1984) at the first of these conferences in 1983. What does appear to be happening is that if advection and circulation are important, it is their effects on upper ocean structure (mixed layer depth, temperature) which, in turn, directly affects biological production.

Citations

- Brodeur, R. D., B. W. Frost, S. R. Hare, R. C. Francis, and W. J. Ingraham. 1996. Interannual variations in zooplankton biomass in the Gulf of Alaska and covariation with California Current zooplankton. *CalCOFI (Calif. Coop. Oceanic Fish. Invest.) Rep.* 37:80-99.
- Brodeur, R. D., and D. M. Ware. 1992. Long-term variability in zooplankton biomass in the Subarctic Pacific Ocean. *Fish. Oceanogr.* 1:32-38.
- Chelton, D. B. 1984. Commentary: Short-term climatic variability in the Northeast Pacific Ocean. *In* W. G. Percy (editor), *The influence of ocean conditions on the production of salmonids in the North Pacific*, p. 87-99. Oregon Sea Grant Program, Oregon State Univ., Corvallis. Publ. ORESU-W-83-001.
- Chelton, D. B., and R. E. Davis. 1982. Monthly mean sea level variability along the western coast of North America. *J. Phys. Oceanogr.* 12:757-784.
- Enfield, D. B., and J. S. Allen. 1980. On the structure and dynamics of monthly mean sea level anomalies along the Pacific Coast of North and South America. *J. Phys. Oceanogr.* 10:557-578.
- Francis, R. C. 1993. Climate change and salmonid production in the North Pacific Ocean. *In* K. T. Redmond and V. L. Tharp (editors), *Proceedings of the Ninth Annual Pacific Climate (PACLIM) Workshop*, p. 33-43. Calif. Dep. Water Resour. (Available from California Department of Water Resources, 1416 Ninth St., Rm. 1104-1, Sacramento, CA 95814.)
- Francis, R. C., and S. R. Hare. 1994. Decadal-scale regime shifts in the large marine ecosystems of the North-east Pacific: A case for historical science. *Fish. Oceanogr.* 3:279-291.

- Francis, R. C., S. R. Hare, A. B. Hollowed, and W. S. Wooster. In prep., Effects of interdecadal variability on the oceanic ecosystems of the Northeast Pacific. (Submitted to *J. Climate*.)
- Freeland, H. J. 1990. Sea surface temperatures along the coast of British Columbia: Regional evidence for a warming trend. *Can. J. Fish. Aquat. Sci.* 47:346-350.
- Hare, S. R. 1996. Low frequency climate variability and salmon production. Ph.D. Thesis, School of Fisheries, University of Washington, Seattle, 306 p.
- Hare, S. R., and R. C. Francis. 1992. An intervention analysis approach to modelling the linkage between Northeast Pacific regime shifts and Alaska salmon production, p. 135-163. *In* Salmon management in the 21st century, Proceedings of the 1992 Northeast Pacific Chinook and Coho Workshop. Idaho Chapter of American Fisheries Society, Boise, Idaho.
- Hare, S. R., and R. C. Francis. 1995. Climate change and salmon production in the Northeast Pacific Ocean. *In* R. J. Beamish (editor), Climate change and northern fish populations, p. 357-372. *Can. Spec. Publ. Fish. Aquat. Sci.* 121.
- Hollowed, A. B., and W. S. Wooster. 1992. Variability of winter ocean conditions and strong year classes of Northeast Pacific groundfish. *Int. Counc. Explor. Sea Mar. Sci. Symp.* 195:433-444.
- Kelly, K. A., M. J. Caruso, and J. A. Austin. 1993. Wind-forced variations in sea surface height in the Northeast Pacific Ocean. *J. Phys. Oceanogr.* 23:2392-2411.
- Lagerloef, G. S. E. 1995. Interdecadal variations in the Alaska Gyre. *J. Phys. Oceanogr.* 25:2242-2258.
- Miller, A. J. 1996. Recent advances in California Current modeling. *CalCOFI (Calif. Coop. Oceanic Fish. Invest.) Rep.* 37:69-79.
- Miller, A. J., D. R. Cayan, T. P. Barnett, N. E. Graham, and J. M. Oberhuber. 1994. The 1976-77 climate shift of the Pacific Ocean. *Oceanography* 7:21-26.
- Miller, A. J., D. R. Cayan, and W. B. White. 1996. Mechanisms of upper-ocean thermal variability in a 1970-1988 simulation and observations. *In* C. M. Isaacs and V. L. Tharp (editors), Proceedings of the Twelfth Annual Pacific Climate (PACLIM) Workshop, p. 19-32. *Calif. Dep. Water Resour. Tech. Rep.* 46.
- Polovina, J. J., G. T. Mitchum, and G. T. Evans. 1995. Decadal and basin-scale variation in mixed layer depth and the impact on biological production in the Central and North Pacific, 1960-88. *Deep-Sea Res.* 42(10):1701-1716.

- Roemmich, D., and J. McGowan. 1995. Climate warming and the decline of zooplankton in the California Current. *Science* 267:1324-1326.
- Tabata, S. 1991. Annual and interannual variability of baroclinic transports across Line P in the northeast Pacific Ocean. *Deep-Sea Res.* 38(Suppl. 1):S221-S245.
- Van Scoy, K. A., and E. R. M. Druffel. 1993. Ventilation and transport of thermocline and intermediate waters in the northeast Pacific during recent El Niños. *J. Geophys. Res.* 98(C10):18083-18088.
- Venrick, E. L. 1994. Scales of variability in a stable environment: Phytoplankton in the Central North Pacific. *In* T. M. Powell and J. H. Steele (editors), *Ecological time series*, Chapter 10. Chapman and Hall, New York.
- Venrick, E. L., J. A. McGowan, D. R. Cayan, and T. L. Hayward. 1987. Climate and chlorophyll α : Long-term trends in the central North Pacific Ocean. *Science* 238:70-72.
- Ware, D. M., and G. A. McFarlane. 1989. Fisheries production domains in the Northeast Pacific Ocean, p. 359-379. *In* R. J. Beamish and G. A. McFarlane (editors), *Effects of ocean variability on recruitment and an evaluation of parameters used in stock assessment models*. *Can. Spec. Publ. Fish. Aquat. Sci.* 108.
- Wickett, W. P. 1967. Ekman transport and zooplankton concentration in the North Pacific Ocean. *J. Fish. Res. Board Can.* 24(3):581-594.



Process and Mechanisms--Estuarine



THE RELATIONSHIP OF ESTUARINE PRIMARY AND SECONDARY
PRODUCTIVITY TO SALMONID PRODUCTION: BOTTLENECK OR
WINDOW OF OPPORTUNITY?

Charles A. Simenstad

Coordinator, Wetland Ecosystem Team
School of Fisheries
University of Washington
Box 357980
Seattle, WA 98195-7980

The Issue

Concepts such as "window of opportunity" and "bottleneck" have been given survival significance in estuaries since we first began evaluating that phase of Pacific salmon (*Oncorhynchus* spp.) early life histories. Estuarine windows of opportunity and bottlenecks both refer to the influence of estuarine conditions (e.g., food, predators, physicochemical conditions affecting physiology and performance, etc.) to enhance or detract from overall survival disproportional to influences in fresh water or the ocean. Early salmon management, and particularly salmon hatchery release policies which generally sought to hold fish to a size and time that minimized estuarine utilization, tended to consider estuaries as "sinks," contributing more to juvenile salmon mortality than survival; despite contrary evidence, these attitudes and practices still persist in many governmental and private salmon hatcheries. These concepts are more recently represented in management paradigms promoting artificial enhancement and manipulation (e.g., salmon hatchery releases) that can be controlled "adaptively" in comparative real time to take advantage of estuarine conditions in order to maximize survival and buffer poor ocean conditions. In employing any of these concepts, we imply that favorable conditions for juvenile salmon rearing in estuaries are "scheduled" or reach some "optimum" or "convergence" that may dictate survival to return as adults. This issue avoids the question of whether the effect of estuarine productivity is independent of other mortality factors in the sequential salmon life history continuum, or whether there are either compensatory or depensatory relationships between estuarine factors and those affecting freshwater and ocean survival.

One factor commonly considered to regulate salmon survival in estuaries is the availability of prey resources; that is, that food carrying capacity is often limiting and that juvenile salmon have evolved to take advantage of maximal periods of estuarine productivity. This might be considered the "bottom-up" regulation of overall salmon production by some average quantity and timing of primary producers and consumers supporting estuarine food webs utilized by juvenile salmon. This is somewhat contrary to the observation that Pacific salmon populations, with their relatively long numerical response times, have evolved diverse life history strategies (types, races, tactical). These strategies compensate for environmental

variation across time and space scales through their *entire* life cycle, and will tend to average out high frequency components of environmental variation (e.g., interannual/freshwater-estuarine-marine), and respond to low frequency components of variability affecting salmon survival (e.g., oceanic regime shifts). It is also important to realize that "top-down" influences, in which predation or competition independent of salmon size or density prevail, may be just as valid a regulator of salmon production.

A bottom-up view of salmon production in estuaries also assumes that the quantity or quality of food can directly or indirectly limit survival--directly by reducing growth and increasing size-dependent mortality, and indirectly by altering salmon behavioral responses (e.g., migration patterns and rates) that increase their risk to mortality agents such as predators. Understanding spatial and temporal variability in the availability of food organisms, as well as the food web processes that support them, might provide a view into comparable variability in salmon survival. Unfortunately, our appreciation of the effects of estuarine variability have not advanced measurably since reviewed in the predecessor workshop in 1983 (Levings 1984, Levy 1984, Simenstad and Wissmar 1984). While we have a marginally better understanding of the structure and processes in estuarine food webs that contribute to salmon production, there has really been no advancement in our understanding of the spatial and temporal variability in food web linkages to salmon or of the response by individual salmon or their populations to this variability.

Estuaries as Pulsed Ecosystems

The essence of estuaries is that they are extremely variable, pulsed ecosystems; the quantity, composition, timing, and rate of primary and secondary production processes supporting juvenile salmon varies extensively over space and time. Juvenile salmon themselves pulse through the systems, although now perhaps at more punctuated frequencies than in pre-hatchery eras. Because of the relative independence of many factors regulating the dynamics of juvenile salmon migrations through estuaries and the production of prey organisms and associated food web processes, overlap and coincidence of salmon with peak prey resource availability are likely to be random and uncoupled.

Food webs of estuaries in the Pacific Northwest are based predominantly on detritus, but the composition of organic matter contributing to the estuarine detritus pool may vary significantly depending upon location (e.g., ecoregion), extent and type of watershed and estuary, climate, geology, and oceanic energy regime, among many factors. Comprehensive, estuary-scale accounting of organic matter production and consumption has not been attempted for many estuaries in the region, but annual carbon input budgets have been calculated for three contrasting estuaries: Hood Canal (Simenstad and Wissmar 1985), Grays Harbor (Thom 1981, 1984), and the Columbia River estuary (Simenstad et al. 1990). Not surprisingly, given the considerably greater extent of the Columbia River watershed, the total annual loading of organic carbon to that estuary is about five orders of magnitude greater than either Hood Canal or Grays Harbor (Fig. 1a). While import of fluvial organic matter

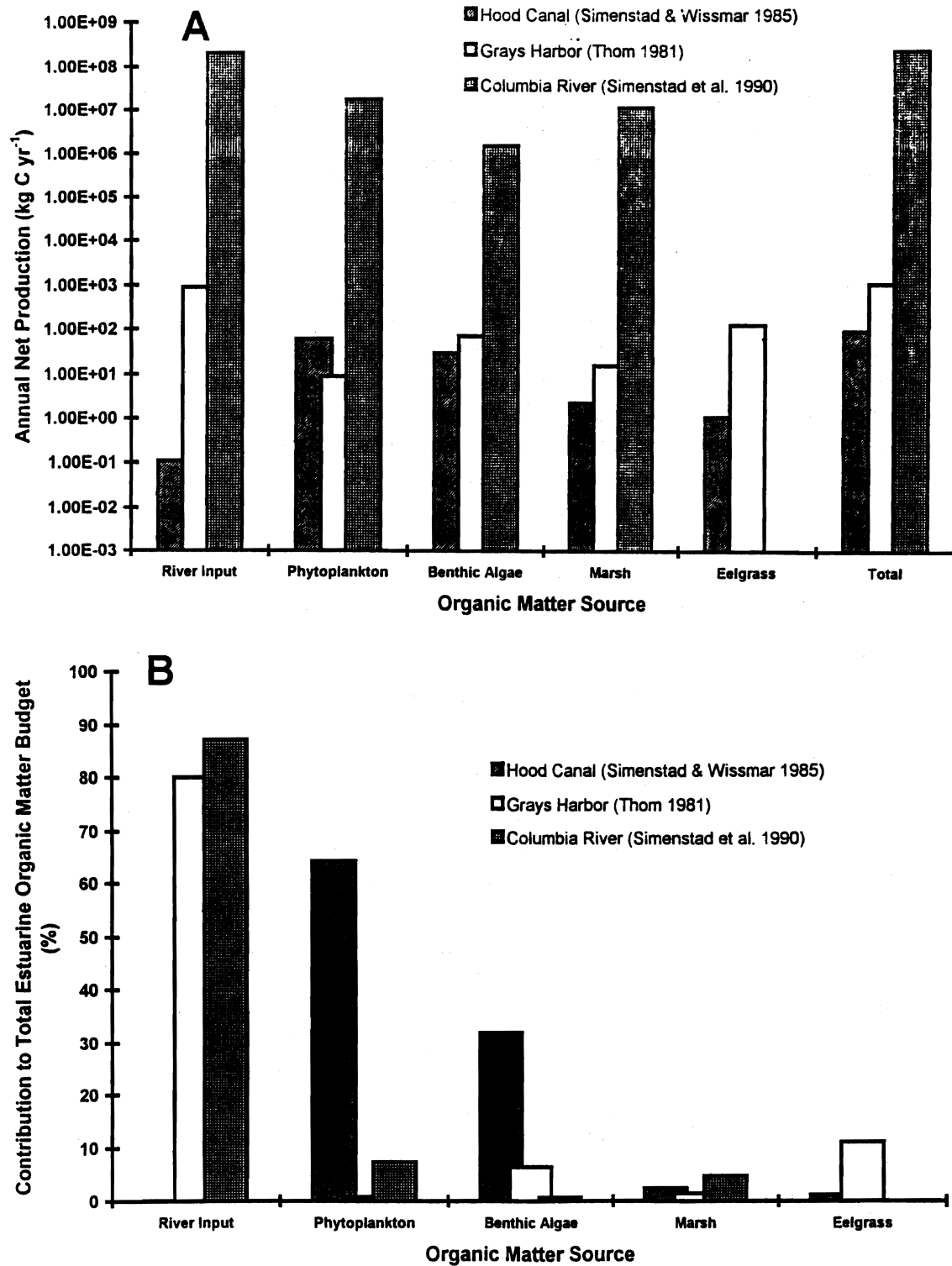

Figure 1. Variability in annual production (kg C yr^{-1}) (A) and of contribution of organic matter sources (B) to three estuaries in the Pacific Northwest: Hood Canal, a fjord adjoining Puget Sound, with numerous deltaic subestuaries; Grays Harbor, a large euhaline, flooded-river-valley coastal estuary; and the Columbia River estuary, a freshwater-dominated estuary with the largest and most diverse watershed in the region.

dominates both the Columbia River estuary (87.2%) and Grays Harbor (80.1%) carbon budgets, phytoplankton (59.7%), and benthic algae (29.7%) contribute much more to the Hood Canal budget, and eelgrass production is of significance (11.3%) primarily in Grays Harbor; emergent marsh production is comparatively insignificant (1.4-4.8%) in all three systems (Fig. 1b).

However, delivery of these different organic matter constituents to the estuarine food web is neither proportional nor coincident to the source inputs. The quality of organic matter is fundamentally more important than bulk organic contribution to the estuary, implying that the sources of organic matter to the estuarine detritus pool may be more important than the bulk delivery. Terrestrial and marsh detritus tends to be much more refractory, and less efficiently incorporated into the estuarine food web, than phytoplankton and benthic algae. Riverine input tends to correspond to river discharge, peaking with winter storms and spring snowmelt, while organic matter from eelgrass production enters the estuary in late winter, benthic algae and phytoplankton in mid-summer, and emergent marsh in the fall (Fig. 2; Thom 1987). Some food web pathways may be almost immediate, as suggested for the incorporation of estuarine foam into littoral flat consumers (Wissmar and Simenstad 1984).

Deterministic Food Web Linkages

Irrespective of the variation in quantity, quality, and timing of organic matter contributing to the food web, we continue to accumulate evidence that certain species and life history stages of juvenile salmon focus their foraging in estuaries on certain types of prey, which in some cases may be an important factor determining estuarine residence time and growth (Wissmar and Simenstad 1988). Results from our on-going studies of juvenile salmon use of estuarine wetlands in Puget Sound and coastal Washington continue to sustain earlier interpretations that certain salmon species and life history types (e.g., chum salmon, *O. keta*, and subyearling chinook salmon, *O. tshawytscha*) prey selectively on specific benthic or epibenthic organisms, such as amphipods (*Corophium* spp.) and harpacticoid copepods (*Harpacticus uniremis*, *Tisbe* sp.) (Simenstad et al. 1988; Wissmar and Simenstad 1988). If we have acquired any additional understanding, it is from tidal freshwater and brackish wetlands, where we also find juvenile salmon (subyearling chinook and coho, *O. kisutch*) feeding concentrated on emergent marsh and riparian insects (e.g., chironomids, aphids) (Shreffler et al. 1992; Miller 1993; Simenstad et al. 1992, 1993, in press; Miller and Simenstad in revision).

Variations in Estuarine Food Webs Supporting Juvenile Salmon

One recent tool that is providing a more powerful identifier of estuarine food web variability is the use of stable natural isotopes, and particularly multiple isotopes (e.g., $\delta^{13}\text{C}$, $\delta^{15}\text{N}$, $\delta^{34}\text{S}$) because significant overlap can occur among isotopic signatures of different

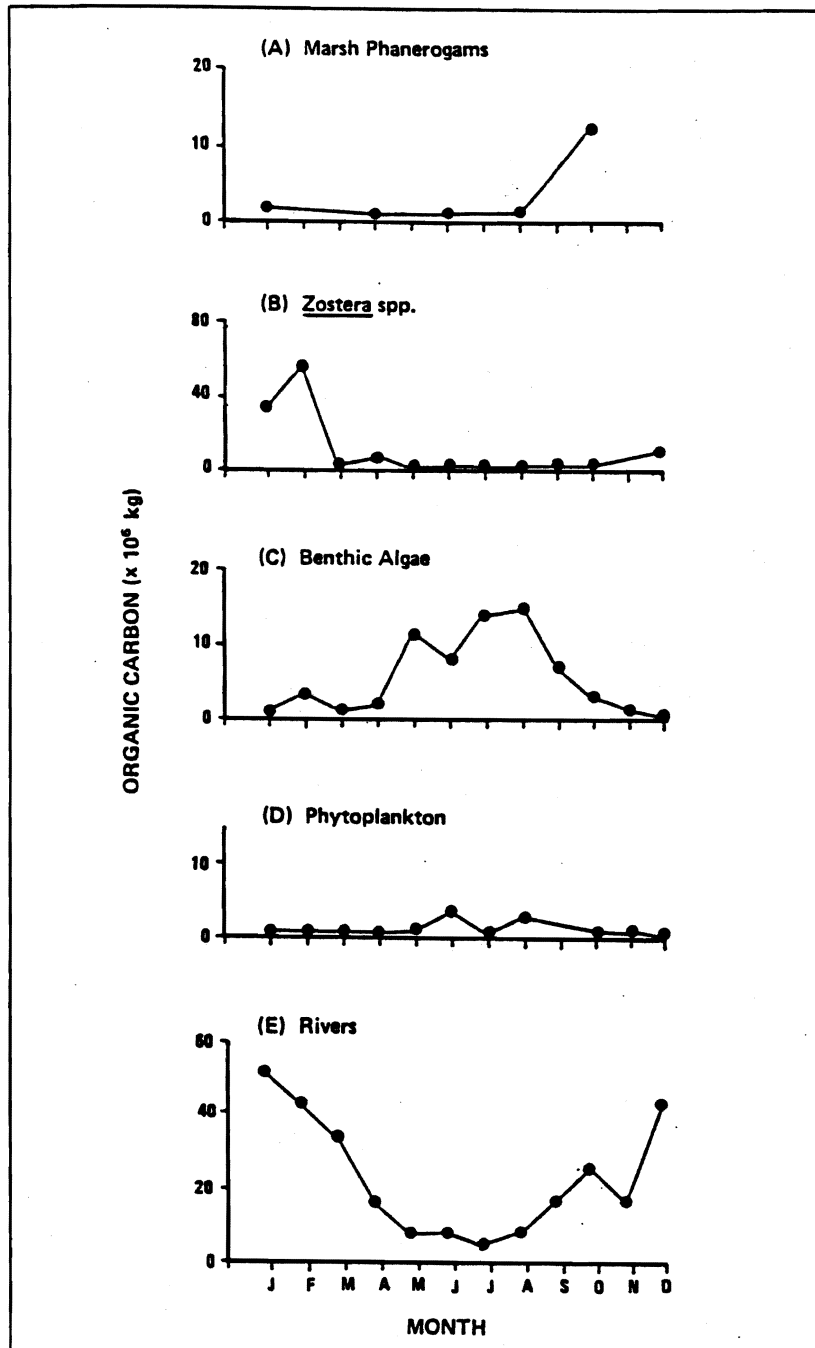

Figure 2. Fluctuations in the input of organic matter to Grays Harbor for different watershed and estuarine sources (From Thom 1981, 1987).

organic sources for any one isotope (e.g., differentiating terrestrial inputs from brackish marsh would be impossible without coupling $\delta^{34}\text{S}$ with $\delta^{13}\text{C}$; addition of $\delta^{13}\text{C}$ further distinguishes trophic level shifts). While $\delta^{13}\text{C}$ analyses of food web sources and pathways have been used to investigate a variety of estuarine systems (e.g., Hood Canal, Simenstad and Wissmar 1985; Padilla Bay, Puget Sound, Simenstad and Wissmar 1985; Fraser River estuary, Levings 1994; Willapa Bay and Columbia River estuary, C. Simenstad, unpubl. data, School of Fisheries, University of Washington, Box 357980, Seattle, WA 98195-7980), the addition of $\delta^{15}\text{N}$ has been incorporated for a few of those systems (Padilla Bay, Fraser River) and $\delta^{34}\text{S}$ has been added for only Willapa Bay and the Columbia River estuary.

As more data from stable isotope studies in these different estuaries emerge, it is becoming apparent that organic matter production and food web processes supporting juvenile salmon production differ across estuaries, often irrespective of seemingly deterministic food web pathways. For instance, $\delta^{13}\text{C}$ of epibenthic harpacticoid copepods and amphipods may vary by as much as 11‰ (-9‰ to -20‰), and the same species, *Corophium salmonis*, can differ by as much as 5.5‰ in adjacent estuaries (Willapa Bay, -18.9‰ vs. Columbia River estuary, -24.4‰). Spatial variation within the same estuary is also evident, as indicated by a wide range in $\delta^{13}\text{C}$ of chinook salmon fry (approximately 20‰ to -30‰) and narrow range (approximately -34‰ to -36‰) for coho salmon presmolts found in the lower Fraser River (Levings 1994), and -19.8‰ for the calanoid copepod *Eurytemora affinis* in the brackish channels of the Columbia River estuary vs. -29.9‰ from the estuarine turbidity maxima in the portion of the same estuary with varying salinities (Simenstad, unpubl. data, School of Fisheries, University of Washington, Box 357980, Seattle, WA 98195-7980); where the $\delta^{15}\text{N}$ signature, 7.4, did not differ at all between these samples). These preliminary indicators of food web pathway variability suggest that both differential pulses of organic matter and heterogeneous distributions of the material across an estuary may account for dramatically different trophic support of secondary consumers such as salmon, especially when salmon localize their rearing and migrations in a specific estuarine region or habitat.

Responses by Salmon to Variability in Estuarine Production

As described in the predecessor workshop in 1983 (Levings 1984; Levy 1984; Simenstad and Wissmar 1984), the issue of carrying capacity limitations for juvenile salmon still remains an untested enigma. Few studies have attempted to describe juvenile salmon production, much less survival, relative to temporal and spatial variability in estuarine biochemical conditions, and most of these are prior to 1983. The descriptive comparisons of juvenile fall chinook salmon relative abundance and size in 11 Oregon estuaries in 1977-82 by Herring and Nicholas (1983) still remains one of the few comparisons between salmon use and estuarine structure. Across the distribution of estuary (at mean lower low water) area, from 6,180 ha for Coos Bay to 90 ha for the Chetco River estuary (Fig. 3a), they found a trend in increasing catch per unit effort (CPUE) and decreasing mean fish size (Fig. 3b), although considerable variability in these trends was also evident. Interannual variation was

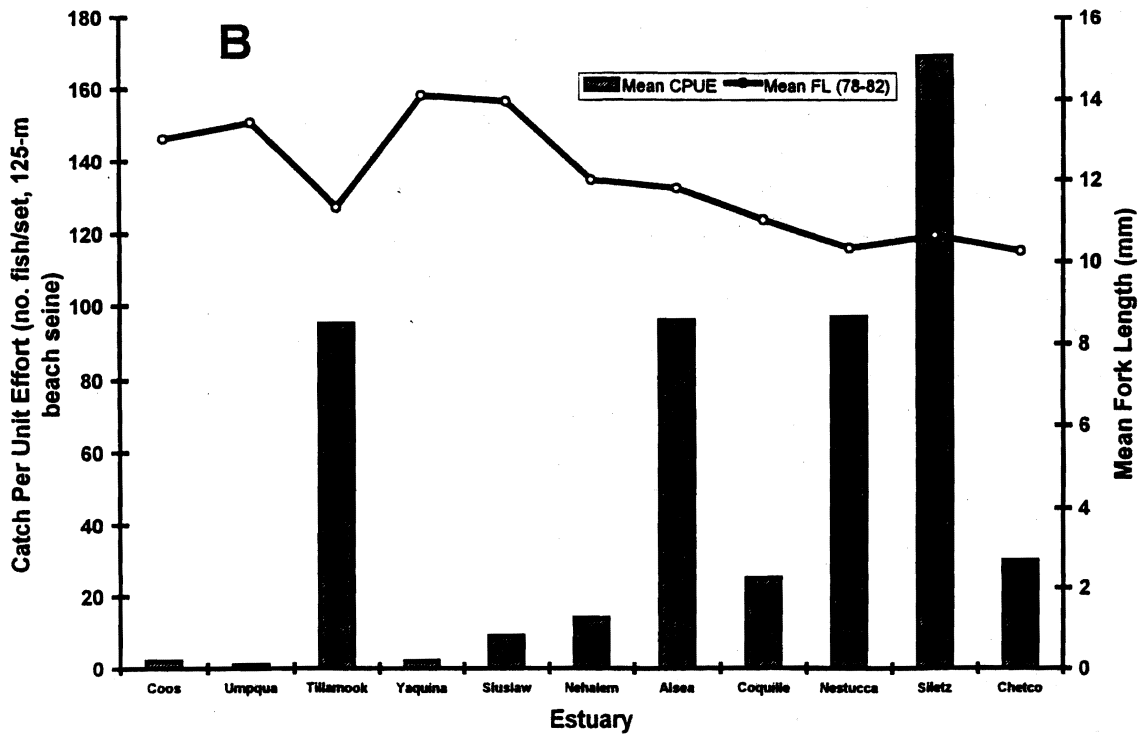
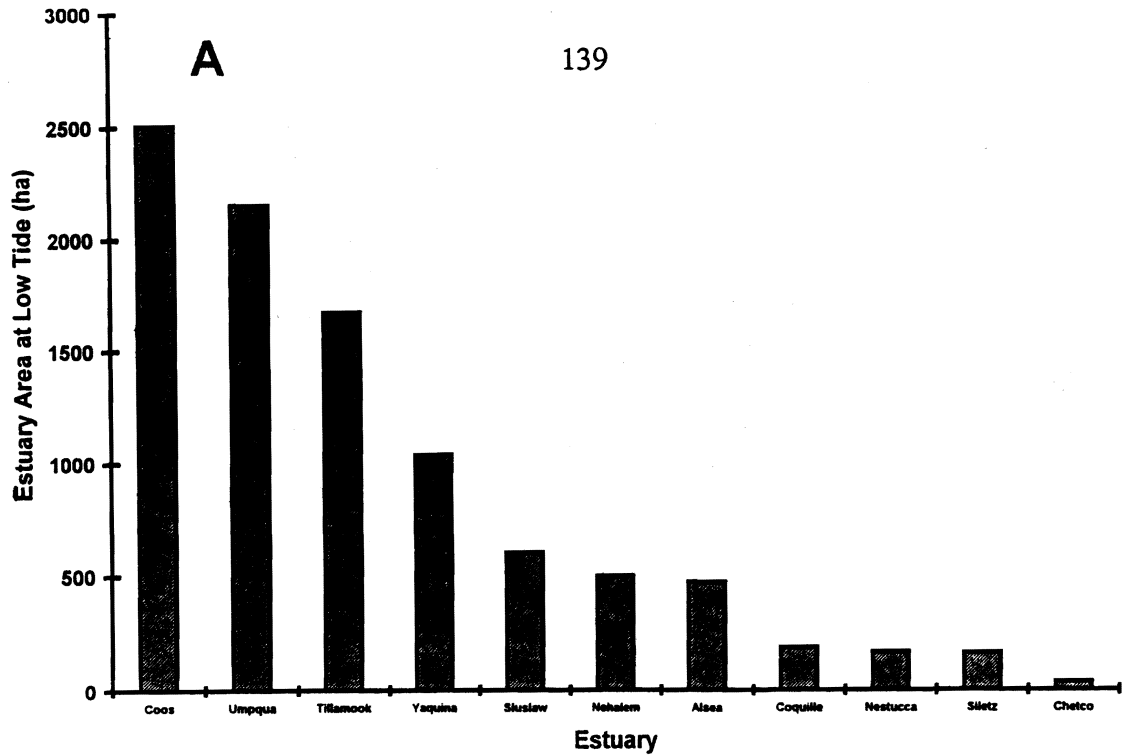

Figure 3. Surface areas of 11 Oregon estuaries (A) (Oregon Division of State Lands 1973) relative to the catch per unit effort (CPUE) and mean fork length of juvenile chinook salmon (B) (Nicholas and Hankin 1988).

also prevalent within the inverse estuary area/fish length relationship (Fig. 4). Suggestion of a density-dependent limitation on fish growth and production (assuming equal emigration and immigration rates), as indicated by fish length, was implicated beyond a CPUE threshold of about 10 to 20 fish per set (Fig. 5). This may coincide with observations from 16 British Columbia estuaries between 1970 and 1982 (Levings 1984) and our own comprehensive estuarine catch data (C. Simenstad, unpubl. data, School of Fisheries, University of Washington, Box 357980, Seattle, WA 98195-7980) that it is rare to find juvenile chinook salmon densities higher than about 1.0 fish m^{-2} . The implications of an estuarine carrying capacity, as modulated by salmon life history type and timing of estuarine entry, is still sustained principally by Reimer's (1973) seemingly ageless study of the survival of chinook salmon life history type in the Sixes River estuary, which we still have yet to repeat or expand upon for any other estuaries.

Conclusions

While the paradigm of detritus-based estuarine food webs may still be generally applicable across salmonid ecosystems, the actual food web processes supporting specific salmonid prey may not be as indicative of broad-based detritus inputs. Factors regulating the production of primary consumers may not necessarily depend on the availability of food resources; while there appear to be chronosequences of benthic/epibenthic prey community structure and production, considerable temporal and spatial variability prevail. Production of key prey species distributed across estuarine gradients, such as insects (chironomids; tidal freshwater-brackish), amphipods (*Corophium* spp., brackish-mesohaline¹), and harpacticoid copepods (*Harpacticus uniremis*, *Tisbe* sp.; salinities varying from 5 ppt to over 30 ppt) may not be coincident, and not necessarily linked to processes (natural, or anthropogenically "managed") that regulate juvenile salmon entry, residence, and survival in the estuary. Alternatively, both physical (inflow, temperature) and biological (primary production, predation) factors that affect juvenile salmon and their prey production may be "optimal" during estuarine residence, but may not coincide with subsequent ocean conditions. Diversity in Pacific salmon species, racial, and tactical life history strategies, which has likely declined under historic exploitation and management, may offer one clue of the salmon's evolutionary solution to such variability in estuarine conditions.

Ultimately, we must recognize that increased knowledge about the influence of dynamic ecosystems such as estuaries on salmon is more likely to elucidate the constraints upon alternative salmon management strategies rather than predictable relationships that can be used to "take advantage" of estuaries. As pointed out by Levings (1984), it may be entirely unrealistic to use production at lower trophic levels as indicators of estuarine

¹Mesohaline is defined as waters of 5-18 ppt.

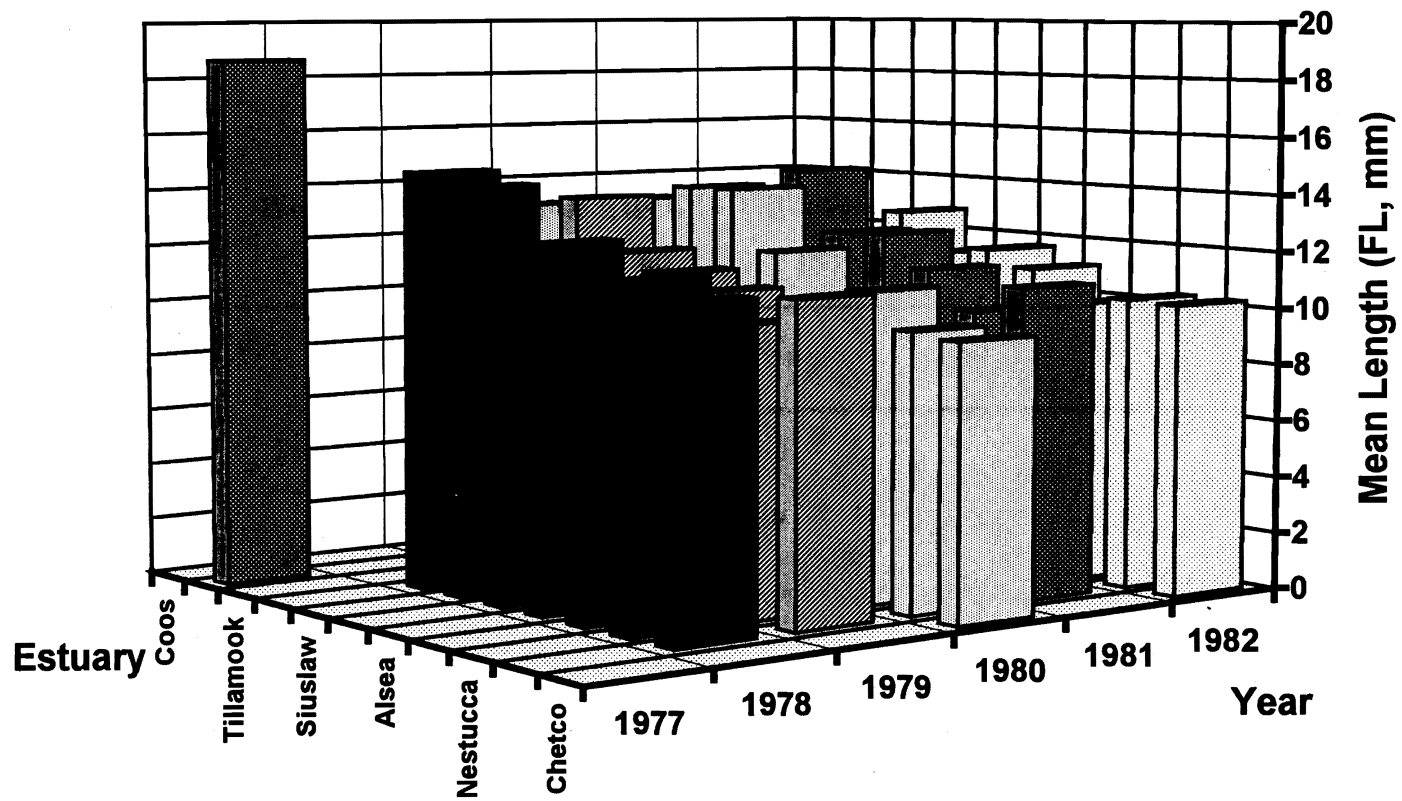

Figure 4. Annual mean fork length of juvenile chinook salmon in 11 Oregon estuaries between 1977 and 1982.

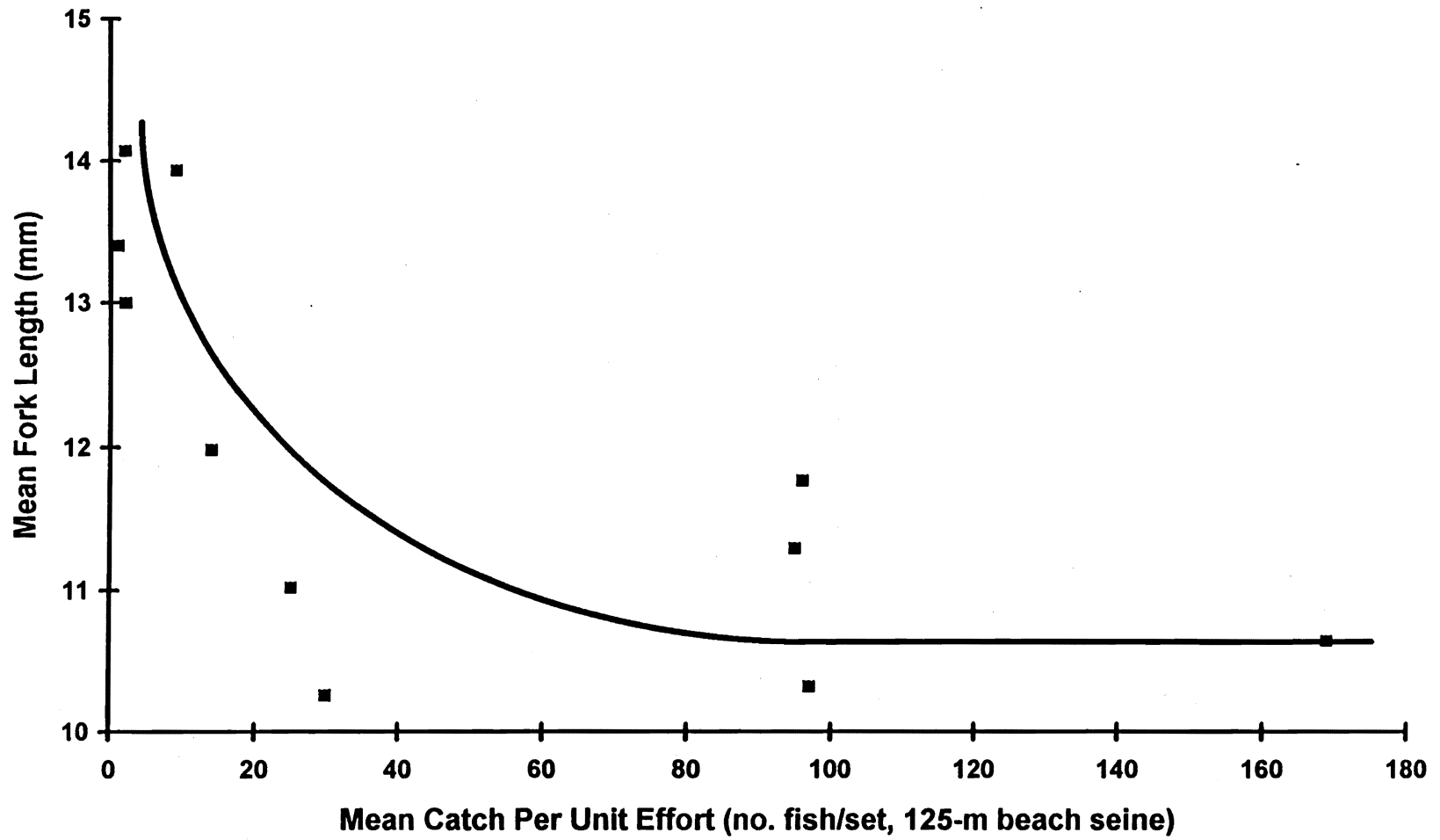

Figure 5. Relationship between mean fork length of juvenile chinook salmon and mean catch per unit effort (CPUE) in 11 Oregon estuaries.

(juvenile salmon) production potential given the variability in fish "dependence" on specific prey or the spatial distribution of prey.

From salmon biologists' perspectives, ecosystem management of salmon must ultimately deal with managing man's adverse impacts on critical ecosystem processes, and within the scope of natural variability, rather than managing ecosystems per se. Understanding the scope of salmon population responses to estuarine variability will require considerably more focused and intense research into issues such as the following: 1) links between variation in estuarine organic matter production and consumer population dynamics, 2) whether pulses of salmon prey resources are interlinked with salmon behavior, 3) relationships between organic matter quality (sources) and consumer (salmon prey) production, 4) variation in juvenile salmon estuarine entry, residence time, growth and mortality, and relationship to primary and secondary food web pulses, 5) effect of life history diversity on estuarine-ocean variability, and 6) the presence or lack of interdependence between estuarine survival and ocean survival.

Citations

- Levings, C. D. 1984. Commentary: Progress in attempts to test the null hypothesis that juvenile salmonids aren't dependent on estuaries. *In* W. G. Percy (editor), The influence of ocean conditions on the production of salmonids in the North Pacific: A workshop, p. 287-296. Oregon State Univ., Corvallis, OR. Sea Grant Col. Prog., ORESU-W-83-001.
- Levings, C. D. 1994. Life on the edge: Structural and functional aspects of chinook and coho salmon rearing habitats on the margins of the lower Fraser River. *In* Salmon ecosystem restoration: Myth and reality, Proceedings of 1994 Northeast Pacific Chinook and Coho Salmon Workshop, p. 139-147. Oregon Chapter, Am. Fish. Soc., Corvallis, OR.
- Levy, D. A. 1984. Commentary: Variations in estuary utilization among juvenile chinook salmon populations. *In* W. G. Percy (editor), The influence of ocean conditions on the production of salmonids in the North Pacific: A workshop, p. 297-302. Oregon State Univ., Corvallis, OR. Sea Grant Col. Prog., ORESU-W-83-001.
- Miller, J. A. 1993. Juvenile chinook (*Oncorhynchus tshawytscha*) and coho (*O. kisutch*) salmon in natural and created estuarine habitats: Foraging and daily growth. M.S. Thesis, Univ. Washington, Seattle, WA, 84 p.
- Miller, J. A., and C. A. Simenstad. In prep. Juvenile chinook and coho salmon use of a natural and created estuarine slough on the Chehalis River, WA: Short-term growth, residence, and foraging. Estuaries.

- Nicholas, J. W., and D. G. Hankin. 1988. Chinook salmon populations in Oregon coastal river basins: Description of life history and assessment of recent trends in run strengths. Oregon Dept. Fish Wildl., Info. Rep. 88-1, 359 p.
- Oregon Division of State Lands. 1973. Oregon estuaries. Salem, OR, 48 p.
- Reimers, P. E. 1973. The length of residence of juvenile fall chinook in the Sixes River, Oregon. Fish. Comm. Oreg. Res. Rep. 4(2):3-42.
- Sherwood, C. R., D. A. Jay, R. B. Harvey, P. Hamilton, and C. A. Simenstad. 1990. Historical changes in the Columbia River estuary. Prog. Oceanogr. 25:299-357.
- Shreffler, D. K., C. A. Simenstad, and R. M. Thom. 1992. Foraging by juvenile salmon in a restored estuarine wetland. Estuaries 15:204-213.
- Simenstad, C. A., J. R. Cordell, W. G. Hood, B. E. Feist, and R. M. Thom. In press. Ecological status of a created estuarine slough in the Chehalis River estuary: Assessment of created and natural estuarine sloughs, January-December 1995. Fish. Res. Inst., School Fish., Univ. Wash., Seattle, WA, 81 p.
- Simenstad, C. A., J. R. Cordell, W. G. Hood, J. A. Miller, and R. M. Thom. 1992. Ecological status of a created estuarine slough in the Chehalis River estuary: Report of monitoring in created and natural estuarine sloughs, January-December 1991. FRI-UW-9206. Fish. Res. Inst., Univ. Wash., Seattle, WA, 49 p.
- Simenstad, C. A., J. R. Cordell, J. A. Miller, W. G. Hood, and R. M. Thom. 1993. Ecological status of a created estuarine slough in the Chehalis River estuary: Assessment of created and natural estuarine sloughs, January-December 1992. FRI-UW-9305. Fish. Res. Inst., Univ. Wash., Seattle, WA, 56 p.
- Simenstad, C. A., J. R. Cordell, R. C. Wissmar, K. L. Fresh, S. Schroder, M. Carr, and M. Berg. 1988. Assemblages structure, microhabitat distribution, and food web linkages of epibenthic crustaceans in Padilla Bay National Estuarine Research Reserve, Washington. NOAA Tech. Rep. Ser. OCRM/MEMD, FRI-UW-8813, Fish. Res. Inst., Univ. Wash., Seattle, WA, 60 p.
- Simenstad, C. A., C. D. McIntire, and L. F. Small. 1990. Consumption processes and food web structure in the Columbia River estuary. Prog. Oceanogr. 25:271-298.
- Simenstad, C. A., and R. C. Wissmar. 1984. Variability of estuarine food webs and production may limit our ability to enhance Pacific salmon (*Oncorhynchus* spp.). In W. G. Pearcy (editor), The influence of ocean conditions on the production of salmonids in the North Pacific: A workshop, p. 272-286. Oregon State Univ., Corvallis, OR. Sea Grant Col. Prog., ORESU-W-83-001.

- Simenstad, C. A., and R. C. Wissmar. 1985. $\delta^{13}\text{C}$ evidence of the origins and fates of organic carbon in estuarine and nearshore marine food webs. *Mar. Ecol. Prog. Ser.* 22:141-152.
- Thom, R. M. 1981. Primary productivity and carbon input to Grays Harbor estuary, Washington. Grays Harbor and Chehalis River Improvements to Navigation Environmental Studies. Final Report to U.S. Army Corps of Engineers, Seattle District, Seattle, WA, 71 p. (Available from U.S. Army Corps of Engineers, Seattle District Office, 4735 E. Marginal Way S., Seattle, WA 98134.)
- Thom, R. M. 1984. Primary production in Grays Harbor estuary, Washington. *Bull. Southern California Acad. Sci.* 83:99-105.
- Thom, R. M. 1987. The biological importance of Pacific Northwest estuaries. *Northwest Environ. J.* 3:21-42.
- Wissmar, R. C., and C. A. Simenstad. 1984. Surface foam chemistry and productivity in the Duckabush River estuary. *In* V. Kennedy (editor), *The estuary as a filter*, p. 331-348. Academic Press, Orlando, FL.
- Wissmar, R. C., and C. A. Simenstad. 1988. Energetic constraints of juvenile chum salmon (*Oncorhynchus keta*) migrating in estuaries. *Can. J. Fish. Aquat. Sci.* 45:1555-1560.

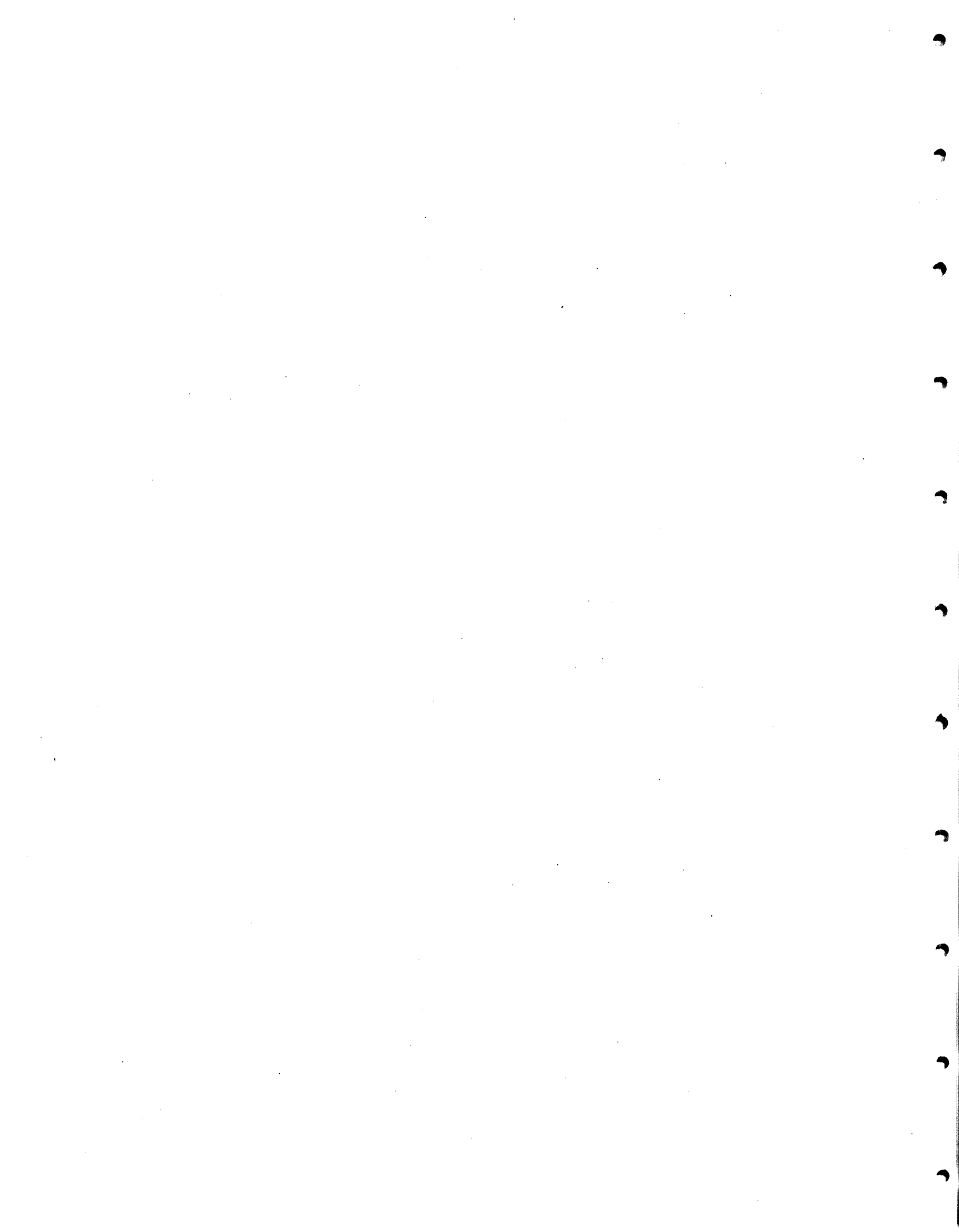

ESTUARINE SURVIVAL OF SALMONIDS: THE IMPORTANCE OF
INTERSPECIFIC AND INTRASPECIFIC PREDATION AND COMPETITION

Robert L. Emmett

National Marine Fisheries Service
Northwest Fisheries Science Center
2030 SE Marine Science Drive
Newport, OR 97365

and

Oregon State University
Department of Fish and Wildlife
Corvallis, OR 97331

Declining salmonid runs on the west coast of North America are a result of many factors, including habitat destruction, hydropower development, overharvest, and ill-conceived hatchery practices. One factor that has received little attention is inter- and intraspecific predation and competition in estuaries. Populations of salmonid predators and possible competitors in estuaries have increased dramatically since the 1970s. In particular, estuarine populations of marine mammals and piscivorous birds have increased significantly. The purpose of this paper is to review the status of salmonid predators and competitors in West Coast estuaries, highlighting current data gaps about these problems.

Predators

Since enactment of the Marine Mammal Protection Act of 1972, Northwest populations of California sea lions (*Zalophus californianus*) and harbor seals (*Phoca vitulina*) have increased steadily and are now healthy, productive, and growing. Many salmonid populations, on the other hand, are unproductive and decreasing, and some are listed as threatened or endangered under the federal Endangered Species Act (Snake River spring/summer and fall chinook salmon (*Oncorhynchus tshawytscha*), Snake River sockeye salmon (*O. nerka*), and Sacramento River winter chinook salmon).

Estuaries are excellent habitat for marine mammals, providing protected haul-out sites and a high abundance of a variety of prey species, including salmonids. However, the degree to which marine mammals prey upon salmonids is poorly understood. Harmon et al. (1994) documented a relatively high prevalence of marine mammal tooth and claw abrasions on adult salmonids passing Lower Granite Dam on the Snake River from 1990 to 1993. These were mostly attributed to sea lions. Their data plus more recent data (Table 1) indicate that, although the prevalence of marine mammal attacks are relatively high, there are no obvious

Table 1. Prevalence of marine mammal tooth and claw abrasions on chinook salmon (*Oncorhynchus tshawytscha*) and steelhead (*O. mykiss*) at Lower Granite Dam on the Snake River.*

Year	Adult fish passing the dam	N	With abrasions %	With open wounds %
Spring/summer chinook salmon				
1990	22,759	1,730	19.2	6.4
1991	125,900	1,325	14.0	6.6
1992	25,219	3,439	14.0	5.1
1993	29,238	3,790	18.3	5.8
1994	4,026	560	25.5	10.7
1995	2,366	518	17.8	5.4
Steelhead				
1990	56,979	3,915	14.2	4.2
1991	99,022	5,957	6.8	2.5
1992	128,163	11,667	5.4	1.3
1993	54,872	4,895	9.5	1.6
1994	47,417	4,074	11.7	3.0
1995	76,446	7,946	16.6	6.3

*Data from Jerry Harmon, National Marine Fisheries Service, Northwest Fisheries Science Center, 2725 Montlake Blvd. E., Seattle, WA 98112-2097.

trends. As marine mammal populations have continued to grow, prevalence of tooth and claw abrasions has not. Moreover, these data provide no information on how many salmonids were actually caught and consumed, nor how many died migrating to Lower Granite Dam (720 km from the mouth of the Columbia River). What these data indicate is that marine mammals do attack and eat salmonids and that there are factors in addition to salmon and marine mammal population abundance that influence marine mammal attacks.

California sea lions

The West Coast California sea lion population is growing rapidly with no indications that it is reaching an optimal sustainable population (OSP) level (i.e., an asymptotic population exponential growth curve). From 1975 to 1994, pup counts of sea lions in California increased at an annual rate of 5.2% and increased regionally 8% per year (Barlow et al. 1995, U.S. Dep. Commer. in prep.). In 1992, sea lion populations were estimated to be approximately 11,000, 17,000, and 30,000 along the coasts of Oregon, Washington, and California, respectively. Total U.S. population of California sea lions was estimated to be between 161,000 and 181,000 in 1994.

Although sea lion food habit studies have provided information on the occurrence of salmonid parts in sea lion diets, most studies have not estimated how many salmonids were consumed. The best evidence for severe marine mammal predation on adult salmonids comes from the Ballard Locks in Seattle, Washington, where the California sea lions have been estimated to consume about 40% of the steelhead (*O. mykiss*) run since 1985/1986 (U.S. Dep. Commer. in prep.).

In the Columbia River, sea lions feed primary on fishes other than salmonids, such as eulachon (*Thaleichthys pacificus*), lamprey (*Lampetra* spp.), Pacific herring (*Clupea pallasii*), rockfish (*Sebastes* spp.), and northern anchovy (*Engraulis mordax*). Nevertheless, salmonids may contribute substantially to the sea lion diet at specific times and locations. There also appear to be more salmonids in the diet now (28% in the 1990s vs. 13% in the 1980s), but this may be a result of improved laboratory procedures (U.S. Dep. Commer. in prep.).

Other feeding studies have been conducted off Cascade Head, Oregon; Rogue River, Oregon; and the Russian River, California. At Cascade Head, mackerel, Pacific herring, skates (*Raja* spp.), cephalopods, spiny dogfish (*Squalus acanthias*), Pacific sand lance (*Ammodytes hexapterus*), rockfish, and northern anchovy were the primary prey, with 33% of the samples containing salmonid remains. In the Rogue River (Roffe and Mate 1984), lamprey were the dominant prey, with steelhead comprising 19% and chinook salmon 3% of the diet by weight. Hanson (1993) found California sea lions were efficient salmonid predators, with a catch rate (number of successful captures/number of attack attempts) of 74% at the mouth of the Russian River. Roffe and Mate (1984) calculated that sea lions consumed less than 1% of the spring chinook run and less than 5% of the summer steelhead run in the Rogue River. More research is needed to identify the relationship between salmonid run

sizes, alternative prey populations, and the number of salmonids eaten by sea lions. Sea lion populations have increased dramatically since 1977/1978, when Roffe and Mate performed their research. It would be valuable to repeat their study.

Harbor seals

In 1977, an estimated 100 harbor seals resided in the Columbia River estuary during May/June, although there are now over 900 (Fig. 1). These are probably minimum estimates because many adults migrate to adjacent estuaries during May/June to pup. Highest numbers in the Columbia River are usually in the fall, winter, and early spring, especially during the annual eulachon run.

Northwest harbor seal populations are growing about 7% per year, with no indications when they will reach OSP level. Only an estimated 2,000 harbor seals resided in Oregon waters in the 1920s, but about 10,100 were found in 1992. Washington's population was estimated to be 34,134 in 1993 and California's over 30,000 in 1994.

Generally, harbor seals do not feed on salmonids as frequently as California sea lions. In Puget Sound, harbor seals feed primarily on Pacific hake (*Merluccius productus*), Pacific tomcod (*Microgadus proximus*), walleye pollock (*Theragra chalcogramma*), flatfish, Pacific herring, shiner perch (*Cymatogaster aggregata*), plainfin midshipman (*Porichthys notatus*), and sculpins, with some predation on adult salmonids (steelhead, and pink (*O. gorbuscha*) and chinook salmon) in the fall.

In Washington outer coastal estuaries and in Oregon, harbor seals have been found to feed primarily on eulachon, northern anchovy, flatfish, crustaceans, smelt, and sculpin. The number of scats containing salmonid remains ranges from 1% to 50%, depending on area, season, and method of analysis (U.S. Dep. Commer. in prep.). In the Russian River, primary prey were flatfish, octopus (*Octopus* spp.), Pacific whiting, hagfish (*Eptatretus* spp.), plainfin midshipman, cusk-eels, smelt, Pacific herring, and perch. Harbor seals had a catch rate (number captured/number of attacks) of only 19%, much less than sea lions (Hanson 1993).

Birds

There are many known avian predators of juvenile salmonids, including cormorants (*Phalacrocorax* spp.), terns (*Sterna* spp.), brown pelicans (*Pelecanus occidentalis*), sooty shearwaters (*Puffinus grisens*), common murre (*Uria aalge*), mergansers (*Mergus* spp.), gulls (*Larus* spp.), belted kingfisher (*Megaceryle alcyon*), grebes, loons (*Gavia* spp.), and herons. Avian predators of adult salmonids include bald eagles (*Haliaeetus leucocephalus*) and osprey (*Pandion haliaetus*).

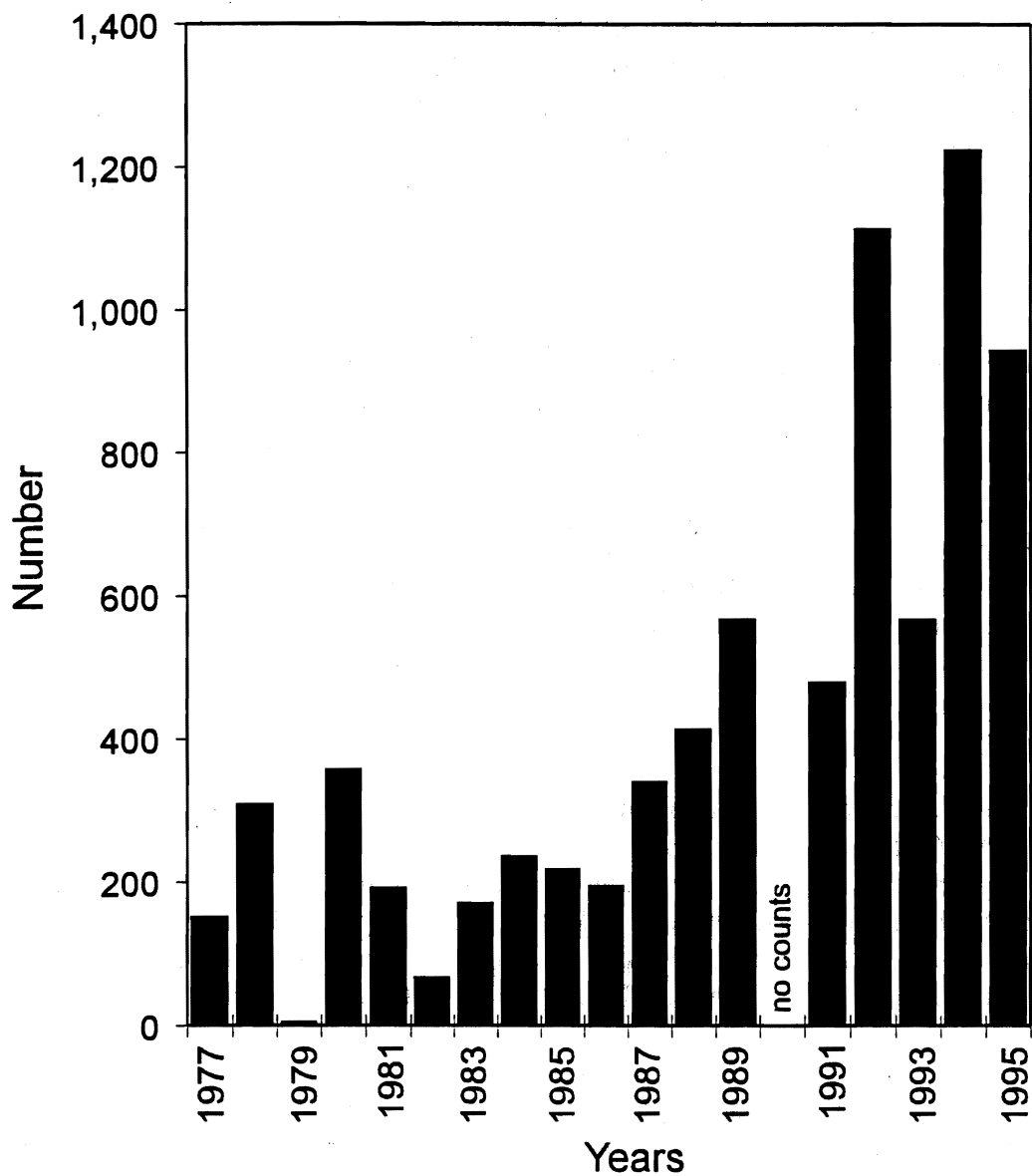

Figure 1. Estimated number of harbor seals (*Phoca vitulina*) residing in the Columbia River estuary during May/June. (Data from Robin Brown, Oregon Dep. Fish Wildl., 7118 NE Vandenberg Ave., Corvallis, OR 97330.)

Two species, sooty shearwater and common murre, reside primarily outside estuaries but eat a considerable number of baitfish and some juvenile salmonids (fish that are often similar in size). In the 1970s, the sooty shearwater population residing during the fall off Oregon was estimated to be over 2 million and consumed about 27.2 million kg of prey (mostly squid and anchovy) (Wiens and Scott 1975). The common murre population along the Oregon coast is estimated to be about 700,000 birds (R. Lowe, U.S. Fish and Wildlife Service, Newport, OR, pers. commun.). The Oregon Institute of Marine Biology (1982) estimated that common murrens consumed 60,000 smolts per day off Coos Bay. These birds concentrated their feeding on recently released hatchery salmonids at the mouth of the bay.

Cormorants

Cormorants are known to consume large numbers of migrating Atlantic salmon (*Salmo salar*) smolts (Kennedy and Greer 1988), significantly affecting local fish abundance (Birt et al. 1987). The double-crested cormorant (*Phalacrocorax auritus*) population off the Pacific coast has increased dramatically over the last decade (Table 2) and is estimated at 48,980 nesting pairs. Large population increases have been observed in British Columbia (1,560%) and Oregon (632%) since 1950 and 1979, respectively (Table 2). However, no data are presently available indicating that this species is concentrating its feeding on salmonid smolts and affecting any specific salmon runs.

Caspian terns

The Pacific Coast population of Caspian terns (*Sterna caspia*) increased 70% from 1960 to 1981 (Gill and Mewaldt 1983) and is probably still increasing. They are known to eat shiner perch, sculpins, coho (*O. kisutch*) and chum salmon (*O. keta*), northern anchovy, smelt, rainbow trout (*O. mykiss*), and jacksmelt (*Atherinopsis californiensis*). Caspian terns inhabit northwestern estuaries from April to August, when adults typically arrive at northwest estuaries in April from southern U.S. Pacific Coast or Central America.

Presently, one of the largest nesting colonies of Caspian terns (about 3,000 nesting pairs) on the West Coast is on Rice Island in the upper Columbia River estuary, an island made from dredged material. This colony became established after 1980, apparently as a result of successful breeding and immigration from other areas. Although there are no Caspian tern food habit data available from this colony, research by Hinton et al. (1992a, 1992b) showed that juvenile salmonids are the dominant fish in this area. Therefore, it is likely that smolts are consumed by birds from this colony. Assuming a breeding population of about 6,000 birds, an average fish weight of 10 g, and some standard biological energy conversions (see Furness and Cooper 1982), I estimate that up to 11 million fish (an unknown number of which would be salmonids) are potentially consumed each season by this colony.

Table 2. Number and percent increase of breeding double-crested cormorants (*Phalacrocorax auritus*) in the Northwest (from Carter et al. 1995).

	1950	1979	1988	1991/1992	Increase (%)
British Columbia	250	1,900	3,900		1,560
Washington inner waters	550	800	1,100		200
Washington outer coast		1,100	600	1,100	0
Oregon		1,978	3,964	12,498	632

Fishes

Although several freshwater studies have reported substantial salmonid predation in fresh water by fishes (see Poe et al. 1991), research by McCabe et al. (1983) and others indicates that large piscivorous fishes that feed on salmonids are not common in most West Coast estuaries. The primary fish predators in estuaries are probably adult salmonids or juvenile salmonids which emigrate at older and larger sizes than others. This would include cutthroat trout (*O. clarki*) or steelhead smolts preying on chum or pink salmon smolts.

Outside estuaries, many large piscivorous fish populations reside just offshore and may consume large numbers of smolts. These fishes include Pacific hake, Pacific mackerel (*Scomber japonicus*), lingcod (*Ophiodon elongatus*), spiny dogfish, various rockfish, and lamprey (Beamish et al. 1992, Pearcy 1992, Beamish and Neville 1995).

Competition

Inter- and intraspecific competition in estuaries is not well documented. Research on the feeding habits of juvenile salmonids in Northwest estuaries indicates a high diet overlap between different species (different salmonids and nonsalmonids) and between hatchery and wild salmonids. However, there are no conclusive data indicating that competition is occurring (Myers 1980, McCabe et al. 1983, Fisher and Pearcy in prep.). Information on salmonid growth rates and prey availability during different years, with and without hatchery influences, would be valuable.

Increased competition may result from the introduction of exotic species which can alter estuarine food webs. Numerous vertebrate and invertebrate species have been introduced into West Coast estuaries. San Francisco Bay in particular has an invertebrate fauna that is now dominated by exotic species that have altered the bay's food web. For example, the Asian clam, *Potamocorbula amurensis*, has reduced abundances of both phytoplankton and copepod populations (Kimmerer et al. 1994). The recent introduction of the freshwater Asian shrimp, *Exopalaemon modestus*, into the Columbia River (personal observation) could impact salmonid resources. If *E. modestus* becomes abundant and preys on and reduces the abundance of the *Corophium* spp. amphipods (the primary prey for juvenile salmonids), smolt growth and survival could be reduced. In general, exotic species can impact salmonid runs if they displace native populations but do not replace them as important salmonid prey.

American shad (*Alosa sapidissima*) were introduced along the West Coast in 1871, 1885, and 1886 (Craig and Hacker 1940) and have been identified as a potential estuarine competitor to salmonids. The largest shad run on the West Coast is in the Columbia River, which reached a peak of 4 million in 1990, declining to 2 million in 1994 (Fig. 2) (ODFW and WDFW 1995). Although the potential for competition between shad and salmonids exists, the migrations in estuaries do not coincide. Adult shad migrate into estuaries primarily

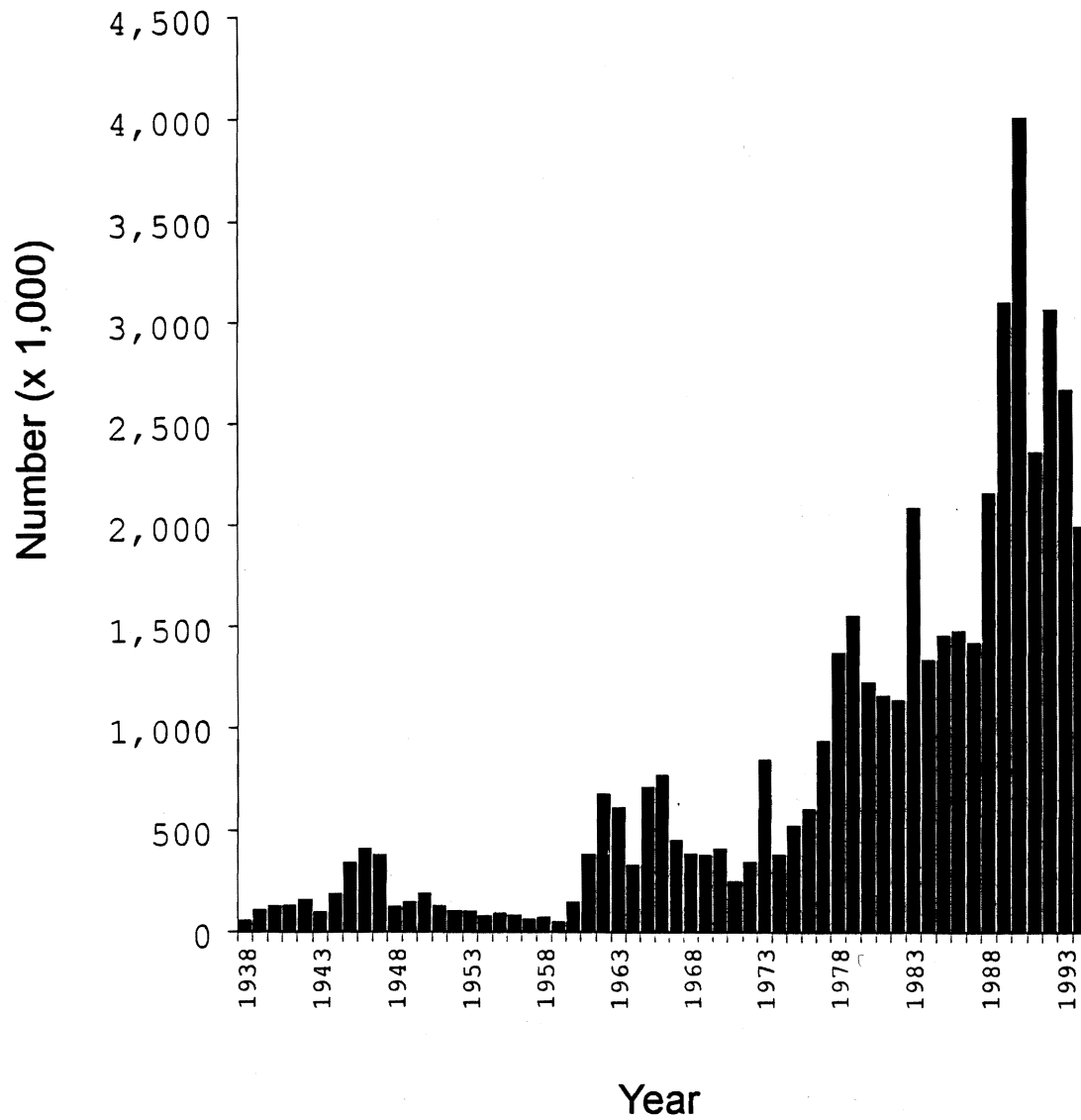

Figure 2. Estimated run size of American shad (*Alosa sapidissima*) in the Columbia River, 1938-94 (from ODFW and WDFW 1995).

in June-July and are not actively feeding. Juvenile shad migrate through the estuary during September-October when most juvenile salmonids have left estuaries.

Conclusions

Estuarine populations of many marine mammals and birds are increasing. These predators may eat a substantial number of salmonids, depending on location, timing, and salmonid and alternative prey abundance. Data on the feeding habits of these predators are critically needed.

Documentation of competition for food in estuaries is very limited. Given the status of many wild salmonid populations, research is needed to identify possible hatchery vs. wild smolt interactions in estuaries.

Introductions of exotic species threaten estuarine food webs. Since most exotic species are introduced by large ship ballast water, legislation forcing ships to off-load, treat, or exchange ballast water at sea, would reduce the risk of exotic species introductions.

Citations

- Barlow, J., R. L. Brownell, Jr., D. P. DeMaster, K. A. Forney, M. S. Lowry, S. Osmeck, T. J. Ragen, R. R. Reeves, and R. J. Small. 1995. U.S. Pacific marine mammal stock assessments. U.S. Dep. Commer., NOAA Tech. Memo. NMFS-SWFSC-219, 162 p.
- Beamish, R. J., and C-E. M. Neville. 1995. Pacific salmon and Pacific herring mortalities in the Fraser River plume caused by river lamprey (*Lampetra ayresi*). Can. J. Fish. Aquat. Sci. 52:644-650.
- Beamish, R. J., B. L. Thomson, and G. A. McFarlane. 1992. Spiny dogfish predation on chinook and coho salmon and the potential effects on hatchery-produced salmon. Trans. Am. Fish. Soc. 121(4):444-455.
- Birt, V. L., T. P. Birt, D. Goulet, D. K. Cairns, and W. A. Montevecchie. 1987. Ashmole's halo: Direct evidence for prey depletion by a seabird. Mar. Ecol. Prog. Ser. 40:205-208.
- Carter, H. R., A. L. Sowls, M. S. Rodway, U. W. Wilson, R. W. Lowe, G. J. McChesney, F. Gress, and D. W. Anderson. 1995. Population size, trends, and conservation problems of the double-crested cormorant on the Pacific Coast of North America. Colonial Waterbirds 18(Spec. Publ. 1):189-215.

- Craig, J. A., and R. L. Hacker. 1940. The history and development of the fisheries of the Columbia River. *Fish. Bull.*, U.S. 32:133-216.
- Fisher, J. P., and W. G. Pearcy. In prep. Food habits of juvenile native and hatchery chinook salmon in Coos Bay, Oregon. Oregon State Univ., Corvallis.
- Furness, R. W., and J. Cooper. 1982. Interactions between breeding seabird and pelagic fish populations in the southern Benguela region. *Mar. Ecol. Prog. Ser.* 8:243-250.
- Gill, R. E., Jr., and L. R. Mewaldt. 1983. Pacific Coast Caspian terns: Dynamics of an expanding population. *The Auk* 100:369-381.
- Hanson, L. C. 1993. The foraging ecology of harbor seals, *Phoca vitulina*, and California sea lions, *Zalophus californianus*, at the mouths of the Russian River, California. M.A. Thesis, Sonoma State Univ., Rohnert Park, CA, 70 p.
- Harmon, J. R., K. L. Thomas, K. W. McIntyre, and N. N. Paasch. 1994. Prevalence of marine-mammal tooth and claw abrasions on adult anadromous salmonids returning to the Snake River. *N. Am. J. Fish. Manage.* 14:661-663.
- Hinton, S. A., R. L. Emmett, and G. T. McCabe, Jr. 1992a. Fishes, shrimp, benthic invertebrates, and sediment characteristics in intertidal and subtidal habitats at Rice Island and Miller Sands, Columbia River Estuary. Report to U.S. Army Corps of Engineers, Contract E96910025, 53 p. (Available from Northwest Fisheries Science Center, 2725 Montlake Blvd. E., Seattle, WA 98112-2097.)
- Hinton, S. A., R. L. Emmett, and G. T. McCabe, Jr. 1992b. Benthic invertebrate and sediment characteristics in subtidal habitat at Rice Island, Columbia River estuary, December 1991 and March 1992. Report to U.S. Army Corps of Engineers, Contract E96920018, 22 p. (Available from Northwest Fisheries Science Center, 2725 Montlake Blvd. E., Seattle, WA 98112-2097.)
- Kennedy, G. J., and J. E. Greer. 1988. Predation by cormorants, *Phalacrocorax carbo* (L.), on the salmonid populations of an Irish river, Northern Ireland, UK. *Aquacult. Fish. Manage.* 19:159-170.
- Kimmerer, W. J., E. Gartside, and J. J. Orsi. 1994. Predation by an introduced clam as the likely cause of substantial declines in zooplankton of San Francisco Bay. *Mar. Ecol. Prog. Ser.* 113:81-93.
- McCabe, G. T., Jr., W. D. Muir, R. L. Emmett, and J. T. Durkin. 1983. Interrelationships between juvenile salmonids and nonsalmonid fish in the Columbia River estuary. *Fish. Bull.*, U.S. 81:815-826.

- Myers, K. W. W. 1980. An investigation of the utilization of four study areas in Yaquina Bay, Oregon by hatchery and wild juvenile salmonids. M.S. Thesis, Oregon State Univ., Corvallis, OR, 234 p.
- Oregon Department of Fish and Wildlife (ODFW) and Washington Department of Fish and Wildlife (WDFW). 1995. Status report: Columbia River fish runs and fisheries, 1938-94. Oregon Dep. Fish Wildl., Portland, OR and Wash. Dep. Fish. Wildl., Olympia, WA, 291 p.
- Oregon Institute of Marine Biology. 1982. The impact of seabird feeding on coho smolt survival. Unpubl. research proposal by Univ. Oregon Inst. Mar. Biol., Charleston, 9 p. (Available from Oregon Institute of Marine Biology, P.O. Box 5389, Charleston, OR 97420.)
- Pearcy, W. G. 1992. Ocean ecology of North Pacific salmonids. Washington Sea Grant, Seattle, 179 p. (Available from Department of Oceanography and Atmospheric Sciences, Bert 114, Oregon State University, Corvallis, OR 97330.)
- Poe, T. P., H. C. Hansel, S. Vigg, D. E. Palmer, and L. A. Prendergast. 1991. Feeding of predaceous fishes on out-migrating juvenile salmonids in John Day Reservoir, Columbia River. *Trans. Am. Fish. Soc.* 120(4):405-420.
- Roffe, T. J., and B. R. Mate. 1984. Abundances and feeding habits of pinnipeds in the Rogue River, Oregon. *J. Wildl. Manage.* 48(4):1262-1274.
- U.S. Department of Commerce. In prep. Review of information on the impacts of California sea lions and Pacific harbor seals on salmonids and the coastal ecosystems of Washington, Oregon, and California. U.S. Dep. Commer., NOAA, Tech. Memo. NMFS-NWFSC.
- Wiens, J. A., and J. M. Scott. 1975. Model estimation of energy flow in Oregon coastal seabird populations. *Condor* 77:439-452.

CRITERIA FOR EVALUATING THE SURVIVAL VALUE OF ESTUARIES FOR SALMONIDS

C. D. Levings¹ and D. Bouillon²

¹Department of Fisheries and Oceans (DFO)
West Vancouver Laboratory
4160 Marine Drive
West Vancouver, BC, Canada V7V 1N6

²ESSA Technologies Ltd., Suite 300
1765 W 8th Avenue
Vancouver, BC, Canada V6J 5C6

It is well known that estuaries have been affected by human use of the coastal zone and in the Northeast Pacific between southwestern British Columbia and California most of these habitats are either degraded or threatened (Levings 1994a). In the life cycle of a salmon, the estuary is also the animal's last "address" where the natural landscape can be changed by the direct activities of industrial activity or urbanization such as filling and direct habitat change. After leaving the estuary, the juvenile salmon's address in the pelagic zone is susceptible to the biophysical attributes of water quality (temperature and salinity) but not to water quantity or direct loss of habitat. However, with the possible exception of greenhouse gases and their effect on global warming, pelagic habitats cannot be "managed." Since decisions about estuarine salmon habitat have significant societal impacts in addition to those dealing with salmonid productivity, it is important to verify the role of estuaries in salmon survival.

We describe a scheme developed by Fox (1991) which may help in the latter exercise, and in the process we briefly review some of the literature on salmon ecology. Fox recognized that concepts used by epidemiologists to test hypotheses on how diseases were spread could be applied to cause-effect relationships for pollution problems. By applying the null hypothesis, scientists are forced to consider how much information must be ignored to conclude that a causal relationship does not exist. In the present paper, we propose an extension to the issue of estuarine habitat management for maintenance of salmon production. Using seven criteria, the object of the scheme is to "draw together all the disparate threads of evidence and make them into a coherent whole, so that scientifically and socially defensible regulatory decisions can be made" (Fox 1991). The seven criteria are as follows: probability, time order or chronological relationship, strength of the association, specificity, consistency of the association upon replication, predictive performance, and coherence. Because the scheme is based on the functioning of natural systems, we have restricted our considerations to wild salmon since it is well known that hatchery reared fish show very different patterns of estuarine use relative to wild stocks (e.g., Myers 1978, Levings et al. 1986).

Probability

Rice (1993) used the kernel estimator methodology to determine cumulative probability ogives for the abundance of several fish species including Atlantic cod (*Gadus morhua*) and Atlantic salmon (*Salmo salar*). We have tested this nonparametric technique with beach-seine data for juvenile hatchery chinook salmon (*Oncorhynchus tshawytscha*) at the Campbell River estuary. We used salinity as a parameter and found the method shows some promise to give predictions about the salinity adaptations of young salmon (Fig. 1). The preliminary results showed that while there is 80% probability of catch per unit of effort (CPUE) of 15 at 0.5‰, the probability of this CPUE at a higher salinity (5‰) is only about 10%. This indicates that hatchery chinook were more abundant in the lower salinity habitats of the estuary, probably in response to osmoregulatory requirements.

Time Order or Chronological Relationship

Fry from ocean-type chinook, chum (*O. keta*), and certain sockeye (*O. nerka*) salmon stocks undergo a rearing migration from freshwater habitats in the upper estuary to brackish areas of intermediate salinity and finally into marine habitats as they complete smoltification (Levy and Northcote 1982, Levings et al. 1986, Birtwell et al. 1987). The residence time of the fish in particular salinity regimes is attuned to the species' development of osmoregulatory ability at certain sizes and ages. The movement through the estuary over the spring to summer period follows an adaptive chronology which bears out the survival value of estuarine residency.

Strength of the Association

It is a qualitative, but well-documented, observation that juvenile ocean-type chinook salmon appear to be strongly linked to estuarine habitats since they reside in these habitats for 1 to 2 months (e.g., Healey 1982, Levy and Northcote 1982). Many estuaries almost totally drain with falling tides and are characterized by strong currents (e.g., Campbell River estuary; $> \text{one m}\cdot\text{s}^{-1}$, Ages et al. 1990) and shallow brackish layers which a priori might lead to flushing the fry out of these habitats. However, they are adapted to remain and rear before smoltification and departure to the open sea.

Specificity

Specificity refers to the precision of the association between a cause (X) and an effect (Y). Does X lead only to Y (specificity of effect) or does only X lead to Y (specificity of cause) (Fox, 1991)? In our context the question could be reformulated to ask if the loss (X) of an estuary in the life history of a particular wild salmon stock leads to decreased survival

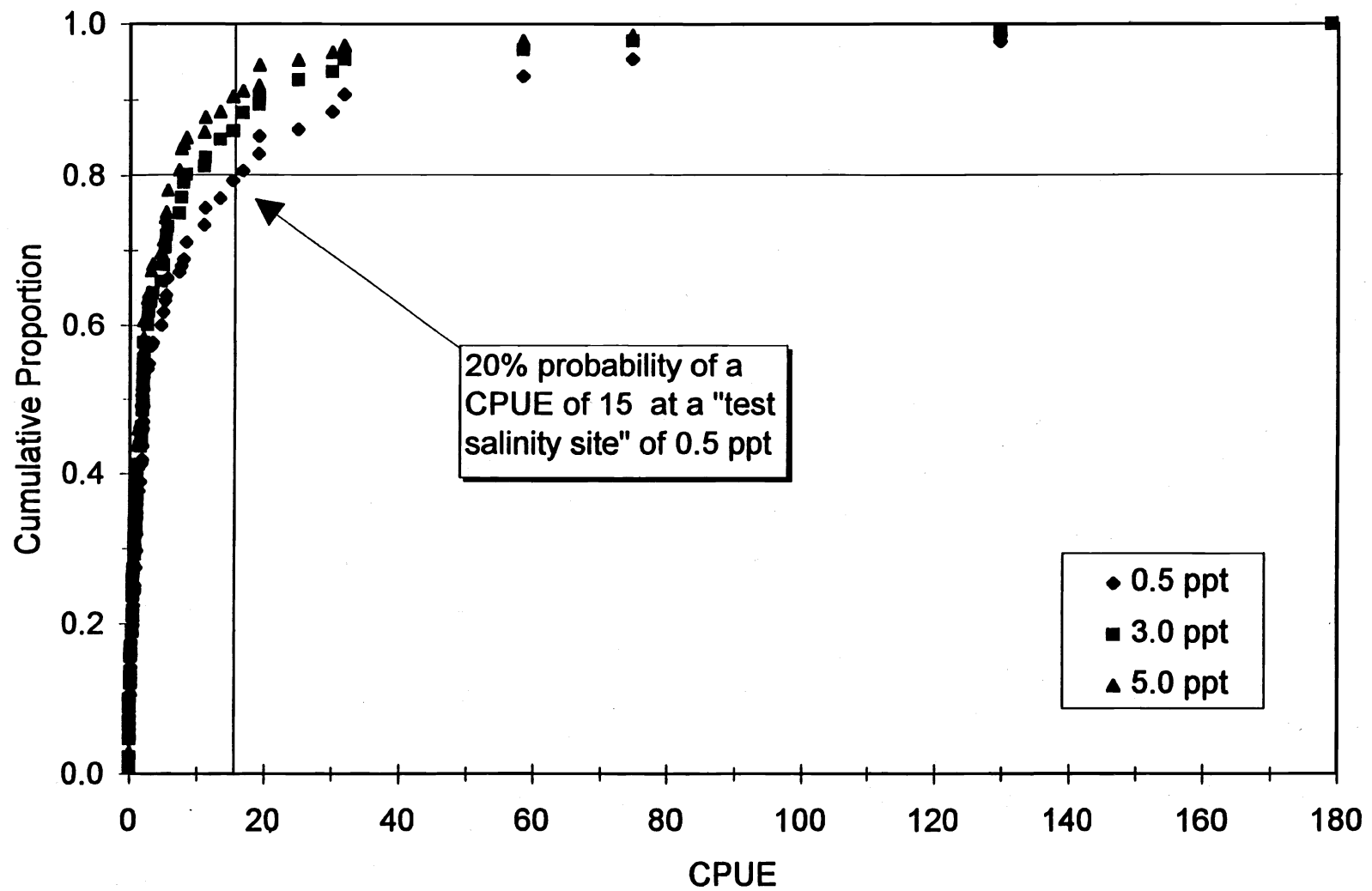

Figure 1. Example of probability density function for juvenile chinook salmon catch per unit effort (CPUE) relative to salinity at Campbell River estuary (unpublished data).

(Y) (specific of effect). It is obvious that a very elaborate and detailed research program would be needed to identify the second part of the proposal, namely specificity of cause.

The initial observations of Reimers (1973) in Oregon estuaries concerning the relative survival of several chinook salmon life history types that showed differences in estuarine use led to several major research programs in estuaries of the Northeast Pacific. This question was asked in a series of habitat release experiments with juvenile chinook salmon at the Campbell River estuary, as described in Levings (1984), Macdonald et al. (1988), and Levings et al. (1989). Releases of specially marked fish were made to river, estuary, transition, and marine habitats in 1983, 1984, and 1985. About 35,000 fish were released into the four habitats each year. Results showed that survival, to catch and escapement, of the fish that transitted the estuary was higher than for those that did not (Table 1). A similar result was found with steelhead (*O. mykiss*) reared and released in the estuary of the Keogh River on Vancouver Island. Releases directly to ocean habitats also showed lower survival in the latter experiments. However, there were numerous complications to the interpretations of the results of both the chinook salmon experiments (Levings et al. 1989) and the steelhead releases (Ward and Slaney 1990), including size effects and differences in temperature and ocean conditions that the three brood years were exposed to.

Consistency of the Association upon Replication

Levings (1984) summarized data to show that densities of juvenile salmon in estuaries were within a relatively narrow range, which might suggest some consistency in the number of juvenile salmon that the estuaries could support. To further assess the use of this concept to ecological data on the importance of estuaries to juvenile salmon, we assembled data on instantaneous growth in weight for chinook and chum salmon in six estuaries off the Strait of Georgia (Fig. 2). The six estuaries might be considered replicates of the habitats and ecosystems we are concerned with. Instantaneous growth rates for chinook salmon ranged between 0.02% and 0.04% and for chum salmon between 0.01% and 0.03%. These data show that growth in the various estuaries did not vary randomly over the landscapes sampled. These findings suggest that these wild salmonids are adapted to estuarine rearing and imply that growth was not being impaired, relative to comparisons possible with this particular data set.

Predictive Performance

In a quantitative or statistical sense (as per Fox 1991), predictive performance may be interpreted as the size of effect produced by the presumptive cause. For example, Morley et al. (1996) used response surface analysis to investigate relationships between size and time of release of hatchery reared chinook salmon. Experiments were conducted in 1982 and 1983, with releases in May, June, and July. Results showed that fish released in May had best survival and that time effects were apparently more important than those for size.

Table 1. Total number of tags recovered from experimental releases of juvenile chinook salmon into four habitats at Campbell River estuary (unpublished DFO data subject to verification, compiled to 1991).

Habitat/Year	River	Estuary	Transition	Marine	Total
1983	136	161	45	25	367
1984	83	102	33	27	245
1985	150	137	140	137	564
Total	369	400	218	189	1,176

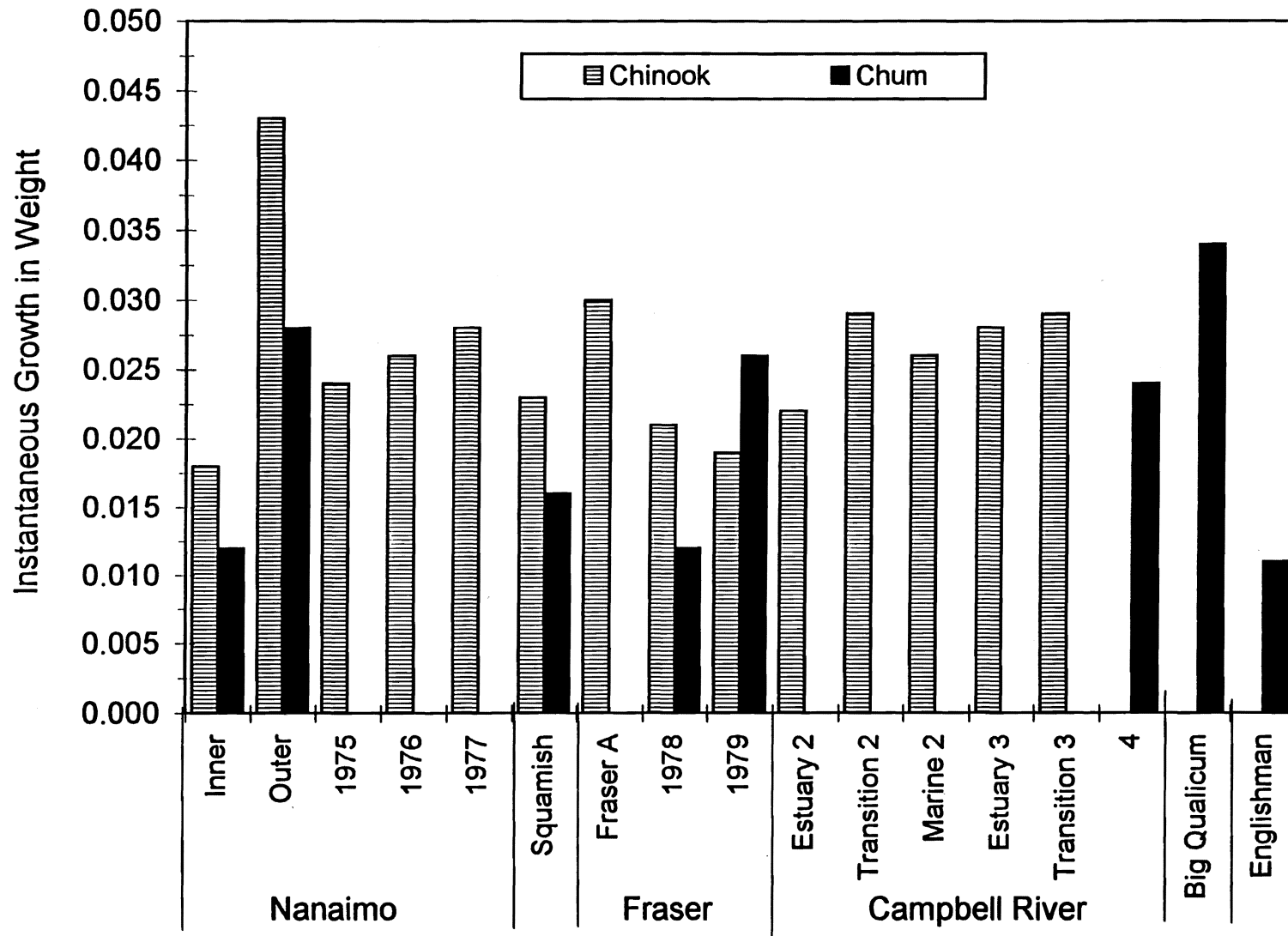

Figure 2. Instantaneous growth in weight for wild juvenile chinook salmon at six estuaries off the Strait of Georgia (data from sources cited in Bouillon 1996).

Coherence

Sibert and Kask (1978) analyzed the correlations between the diet of juvenile chinook salmon at the Nanaimo, Cowichan, Fraser, and Campbell River estuaries, as measured by conventional taxonomic methods. They found significant correlations in a minority of cases, indicating low coherence in fish diets at the four estuaries. It is clear that factors such as prey size, color, behavior, and perhaps nutrition may be important factors influencing prey selection from the suite of available organisms (Levings 1994b, Higgs et al. 1995). However, coherence in food webs may also be assessed by methods such as radiotracer experiments or stable isotope concentrations at various trophic levels. Over the past two decades there have been numerous papers which show that juvenile salmonids are linked to the detritus-based food webs of estuaries (e.g., Sibert et al. 1977, Simenstad and Wissmar 1985, Levings 1994c). These reports support the idea that heterotrophy and detrital production are responsible for coherent energy flow patterns in Northeast Pacific estuaries.

Conclusions

Several experiments have investigated the causal relationship between estuaries and survival of juvenile salmonids since the 1983 Workshop (Levings 1984), but it is clear that much research has yet to be done in this particular habitat. The existing data, tested using a causal inference scheme, supports the rejection of the null hypothesis that estuaries are not important for salmon survival. Salmon ecologists from outside the Northeast Pacific, notably Thorpe (1994), agree with this conclusion based on evolutionary considerations. Thorpe concluded that wild pink (*O. gorbuscha*), chum, some sockeye, and ocean-type chinook salmon are adapted to rear in estuaries and thus their natural habitat characteristics have survival value relative to fresh water. Evidence for the significance of smolt rearing in estuaries by coho, most sockeye, stream-type chinook, masu (*O. masou*), and Atlantic salmon, cutthroat and brown trout (*Salmo trutta*), and steelhead is more equivocal.

One of the problems of resolving the question of the importance of estuaries for salmon in the Northeast Pacific is the fact that most of the data are from south of 50°N latitude where stocks are dominated by hatchery fish and habitats are disrupted. Thus many of the data are not applicable to more northern areas where a major concerted effort must be maintained to preserve wild stocks and natural habitat. In some designated watershed-estuary ecosystems, production of salmon may have to be sacrificed to conservation if we are to appreciate and understand the role of estuaries in salmon ecology (Levings 1993).

Acknowledgments

Thanks are owed to Derek Nishimura for assistance with computing probability density functions. Some of the work reported herein was supported by the DFO Habitat Action Plan, Environmental Analysis component.

Citations

- Ages, A. B., F. A. Dobbs, and C. D. McAllister. 1990. The salinity intrusion in the Campbell River estuary: Salinity, temperature and current observations, 1984-1986. *Can. Data Rep. Hydrog. Ocean Sci.* 83(1):1-243 and 83(2):1-191.
- Birtwell, I. K., M. D. Nassichuk, and H. Buene. 1987. Underyearling sockeye salmon (*Oncorhynchus nerka*) in the estuary of the Fraser River. *In* H. D. L. Smith, L. Margolis and C. C. Wood (editors), Sockeye salmon (*Oncorhynchus nerka*) population biology and future management. *Can. Spec. Publ. Fish. Aquat. Sci.* 96:25-35.
- Bouillon, D. 1996. A comparison of growth and bioenergetic consumption of juvenile salmon in several estuaries of the Strait of Georgia, 68 p. (Available from DFO, West Vancouver Laboratory, West Vancouver, BC, Canada.)
- Fox, G. A. 1991. Practical causal inference for ecoepidemiologists. *J. Toxicol. Environ. Health* 33:359-373.
- Healey, M. C. 1982. Juvenile Pacific salmon in estuaries: The life support system. *In* V. S. Kennedy (editor), *Estuarine comparisons*, p. 315-342. Academic Press, New York.
- Higgs, D. A., J. S. Macdonald, C. D. Levings, and B. Dosanjh. 1995. Nutrition and feeding habits of Pacific salmon (*Oncorhynchus* spp.) in relation to life history stage. *In* R. Brett, W.C. Clarke, K. Groot, and L. Margolis (editors), *Physiological ecology of Pacific salmon*, p. 161 to 315. Univer. B.C. Press, Vancouver, B.C.
- Levings, C. D. 1984. Commentary: Progress in attempts to test the null hypothesis that juvenile salmonids aren't dependent on estuaries. *In* W. G. Pearcy (editor), *The influence of ocean conditions on the production of salmonids in the North Pacific*, p. 287-296. Oreg. State Univ., Sea Grant Coll. Prog. ORESU-W-83-001.
- Levings, C. D. 1993. Requirements for genetic data on adaptations to environment and habitats of salmonids. *In* J. G. Cloud and G. H. Thorgaard (editors), *Proceedings of NATO Advanced Study Institute: Genetic Conservation of Salmonid Fishes*, Moscow, Idaho, June 23-29, 1992, p. 49-65. Plenum Press, New York.
- Levings, C. D. 1994a. Science and management needed to maintain salmon production in estuaries of the Northeast Pacific. *In* K. Dyer and R. J. Orth (editors), *Proceedings Joint Symposium of Estuarine Research Federation and Estuarine and Coastal Sciences Association*, September 14-18 1992, Plymouth, England, p. 417-421. Olsen and Olsen, Denmark.

- Levings, C. D. 1994b. Feeding behaviour of juvenile salmon and significance of habitat during estuary and early sea phase. *Nordic J. Freshw. Res.* 69:7-16.
- Levings, C. D. 1994c. Life on the edge: Structural and functional aspects of chinook and coho rearing habitats on the margins of the lower Fraser River. *In* Salmon ecosystem restoration: myth and reality, Proceedings of 1994 Northeast Pacific Chinook and Coho Salmon Workshop, Oregon Chapter, American Fisheries Society, Corvallis, OR, p. 139-147.
- Levings, C. D., McAllister, C. D., and B. D. Chang. 1986. Differential use of the Campbell River estuary, British Columbia, by wild and hatchery reared juvenile chinook salmon (*Oncorhynchus tshawytscha*). *Can. J. Fish. Aquat. Sci.* 43:1386-1397.
- Levings, C. D., C. D. McAllister, J. S. Macdonald, T. J. Brown, M. S. Kotyk, and B. A. Kask. 1989. Chinook salmon (*Oncorhynchus tshawytscha*) and estuarine habitat: A transfer experiment can help evaluate estuary dependency. *Can. Spec. Publ. Fish. Aquat. Sci.* 105:116-122.
- Levy, D. A., and T. G. Northcote. 1982. Juvenile salmon residency in a marsh area of the Fraser River estuary. *Can. J. Fish. Aquat. Sci.* 39:270-276.
- Macdonald, J. S., C. D. Levings, C. D. McAllister, U. H. M. Fagerlund, and J. R. McBride. 1988. A field experiment to test the importance of estuaries for chinook salmon (*Oncorhynchus tshawytscha*) survival: short term results. *Can. J. Fish. Aquat. Sci.* 45:1366-1377.
- Morley, R. B., A. Y. Federenko, H. T. Bilton, and S. J. Lehmann. 1966. The effects of time and size at release on returns at maturity of chinook salmon from Quinsam Hatchery, B.C., 1982 and 1983 releases. *Can. Tech. Rep. Fish. Aquat. Sci. No.* 2105. 62 p.
- Myers, K. W. 1978. Comparative analysis of stomach contents of cultured and wild juvenile salmonids in Yaquina Bay, Oregon. *In* S. J. Lipovsky and C. A. Simenstad (editors), Fish food habits studies, p. 155-162. Proceedings of the Second Pacific Northwest Technical Workshop, October 10-13, 1978, Washington Sea Grant, Univ. Washington, Seattle.
- Reimers, P. E. 1973. The length of residence of juvenile fall chinook salmon in Sixes River, Oregon. *Res. Briefs Fish. Comm. Oregon* 4(2):1-43.
- Rice, J. R. 1993. Forecasting abundance from habitat measures using non-parametric density estimate methods. *Can. J. Fish. Aquat. Sci.* 50:1690-1698.

- Sibert, J. R., T. J. Brown, M. C. Healey, B. A. Kask, and R. J. Naiman. 1977. Detritus-based food webs: exploitation by juvenile chum salmon (*Oncorhynchus keta*). *Science* 196:649-650.
- Sibert, J., and B. A. Kask. 1978. Do fish have diets? *In* B. G. Shepherd and R. M. J. Ginetz (rapporteurs), Proceedings of the 1977 Northeast Pacific Chinook and Coho Salmon Workshop, p. 48-56. Fisheries and Marine Service Tech. Rep. 759.
- Simenstad, C. A., and R. C. Wissmar. 1985. $\delta^{13}\text{C}$ evidence of the origins of organic carbon in estuarine and nearshore food webs. *Marine Ecology (Progress Series)* 22:141-152.
- Thorpe, J. E. 1994. Salmonid fishes and the estuarine environment. *Estuaries* 17(1A):76-93.
- Ward, B. R., and P. A. Slaney. 1990. Returns of pen-reared steelhead from riverine, estuarine, and marine releases. *Trans. Am. Fish. Soc.* 119:492-299.

ESTUARINE POLLUTION AND JUVENILE SALMON HEALTH:
POTENTIAL IMPACT ON SURVIVAL

E. Casillas, B. B. McCain, M. Arkoosh, and J. E. Stein

Environmental Conservation Division
Northwest Fisheries Science Center
2725 Montlake Blvd. E.
Seattle, WA 98112-2097

The marked declines in several Pacific Northwest salmon stocks are attributed to the cumulative effects of natural and anthropogenic factors. Although the relative contributions of these factors to changes in individual runs are not well understood, human impacts on the environment have contributed significantly to stock declines in many river systems. Human impacts on various life history stages of salmon in freshwater habitats include certain forest and agricultural practices, dams, water diversions, and urbanization. The addition of hatcheries to mitigate the human-induced losses of habitat has also been recently recognized as another potentially important factor affecting the survival of wild stocks of salmon. In the ocean, an important anthropogenic factor is harvesting, whereas natural environmental factors, including climatic changes, reduced food availability, and predation are the other forces thought to influence survival of juvenile and subadult salmon.

Estuaries serve as the natural linkage for salmon migrating between freshwater and ocean environments, providing the necessary habitat for their transition. Because of the urbanization of many coastal regions, estuaries located near urban centers are known to receive both point and nonpoint inputs of chemical contaminants from municipal and industrial activities. Many of the chemicals from these sources are known to accumulate in estuarine sediments (McCain et al. 1988), and a large number of these chemicals are bioaccumulated by sediment-dwelling organisms, including amphipods and copepods, which are important prey organisms for downstream migrant juveniles of certain salmonid species (McCain et al. 1990). As a result, pollution in urban estuaries is one anthropogenic factor that may influence the survival of juvenile salmon, whether directly in the estuary or subsequently in the nearshore ocean.

Recent studies in several urban estuaries, including San Francisco Bay, Elliott Bay and Commencement Bay in Puget Sound, and the Fraser River estuary in Vancouver, British Columbia, have shown that juvenile fall chinook salmon (*Oncorhynchus tshawytscha*) accumulate significant concentrations of chemical contaminants during their relatively short residence time. In studies conducted in urban estuaries in Puget Sound by our laboratory, we found evidence of exposure to high levels of polycyclic aromatic hydrocarbons (PAHs) and polychlorinated biphenyls (PCBs) (McCain et al. 1990, Stein et al. 1995). For example, we consistently found significantly elevated concentrations of fluorescent aromatic compounds (FACs) in bile of juvenile salmon from urbanized estuaries compared to concentrations in fish

from nonurban estuaries (Fig. 1). Because fish extensively metabolize PAHs, the parent compounds do not accumulate in tissues but are found in the bile as metabolites (Varanasi et al. 1989). Measurement of these metabolites, quantified as FACs, provides an estimate of exposure of fish to PAHs (Krahn et al. 1986). Concentrations of PCBs in the liver of juvenile salmon were also significantly higher in fish from the urban estuaries compared to fish from hatcheries and nonurban estuaries. No significant differences in tissue levels of selected toxic metals were found in this study.

We have also demonstrated in field and laboratory studies that juvenile salmon from polluted environments exhibit abnormalities ranging from subcellular effects to changes in immune function and growth. In many cases the effects alter physiological processes, such that the potential for survival is reduced. As an example, chemically induced immunosuppression and the subsequent increased susceptibility to disease represent a serious problem to exposed animals. Immune dysfunction in mammals and fish has been recognized as a sublethal effect of chemical contaminant exposure affecting both cellular and humoral aspects of the immune system (McLeay and Gordon 1977, Dean et al. 1986, Arkoosh and Kaattari 1987, Rice and Weeks 1989, Thuvander 1989).

In our studies with juvenile salmon, immunocompetence was evaluated by analyzing the functional ability of leukocytes to produce an *in vitro* primary and secondary plaque-forming cell (PFC) response to a foreign antigen. This has been shown to be a very sensitive approach to evaluating the long-term chronic effects of exposure to chemical contaminants for short time periods (Arkoosh and Kattari 1987). We showed that leukocytes of juvenile salmon collected from hatcheries and from a nonurban estuary were able to generate a significantly higher secondary PFC response to a foreign antigen than that produced during the primary PFC response, which is the normal and expected response (Arkoosh et al. 1991). However, an enhanced secondary PFC response did not occur with leukocytes of juvenile salmon exposed to pollution from an urban estuary (Arkoosh et al. 1991) (Fig. 2).

Both PAHs and PCBs are known to induce immunoaltering effects in mammals (Ward et al. 1985, Dean et al. 1990), suggesting that PCBs or PAHs or both may be responsible for a suppressed PFC response to an antigen in juvenile salmon from the contaminated urban estuary. This hypothesis was supported by the results of our recent laboratory studies (Arkoosh et al. 1994). Juvenile chinook salmon were administered sublethal doses of PAHs and PCBs. The exposed fish exhibited suppression of their secondary PFC responses. Thus, an impaired secondary PFC response has been demonstrated in both field and laboratory studies, supporting the putative causal relationship between impaired immunity and chemical contaminant exposure in juvenile fall chinook salmon from polluted urban estuaries.

These physiological effects have recently been linked to increased susceptibility to disease. Infectious diseases are commonly suspected of contributing to mortality of juvenile salmon in estuarine and nearshore environments (Elliott et al. 1995). We collected juvenile fall chinook salmon from urban and nonurban estuaries, and from the respective releasing hatcheries, and exposed them in the laboratory to the marine pathogen *Vibrio anguillarum*.

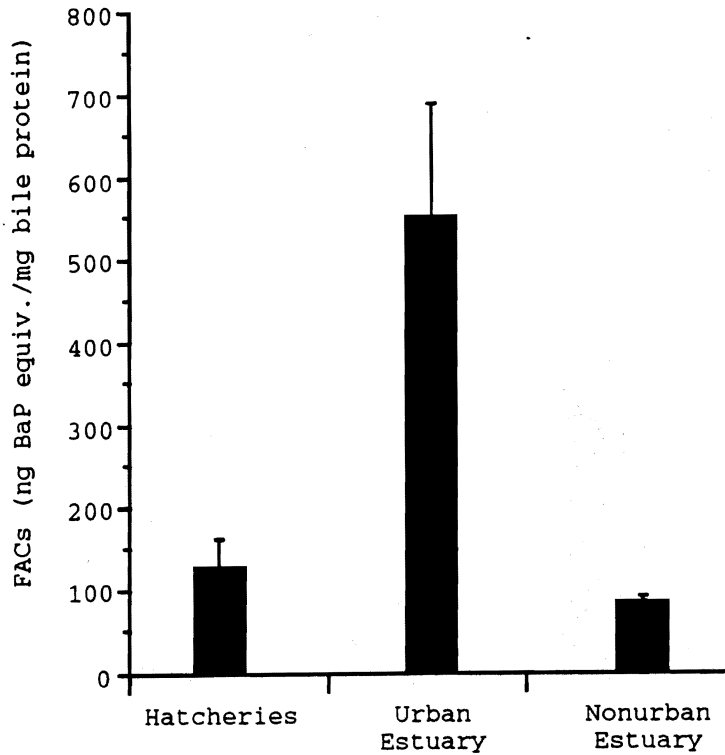

Figure 1. Biliary fluorescent aromatic compounds (FACs) (ng BaP (benzo[a]pyrene) equivalents/mg bile protein) in juvenile salmon from hatcheries, a nonurban estuary (the Nisqually River estuary), and an urban estuary (the Duwamish Waterway) sampled in Puget Sound, Washington in 1990. The bars represent the mean \pm standard error ($n = 3$ to 8). Each sample represents a composite of material from 60 fish (adapted from Stein et al. 1995).

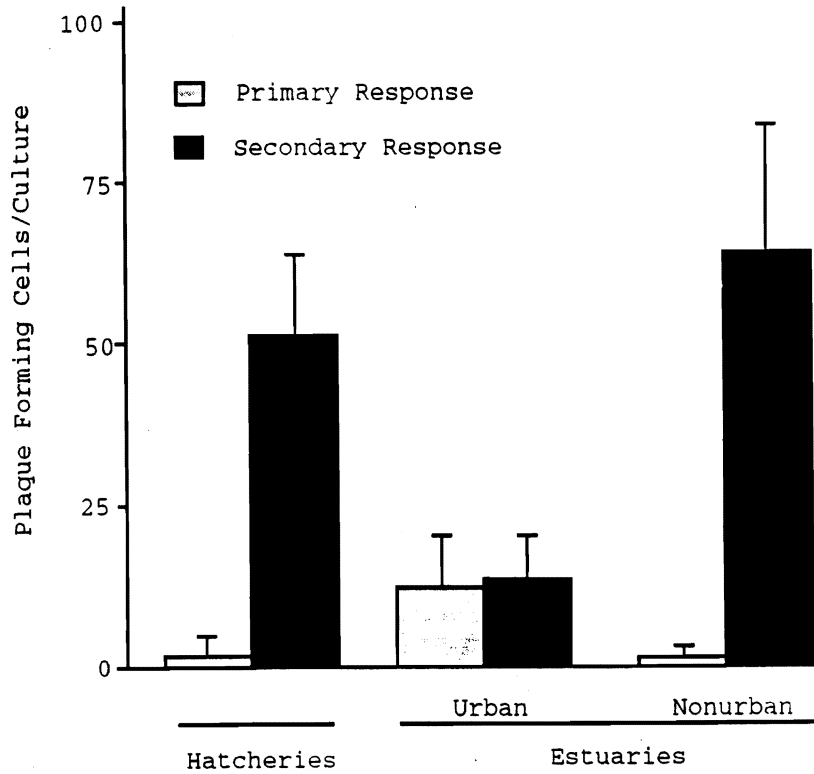

Figure 2. The number of primary and secondary plaque-forming cells/culture of juvenile chinook salmon from the hatcheries, a nonurban estuary (the Nisqually River estuary), and an urban estuary (the Duwamish Waterway) in response to an antigen. The bars represent the mean \pm standard deviation (adapted from Arkoosh et al. 1991).

We found that juvenile chinook salmon from the contaminated estuary were more susceptible to *V. anguillarum*-induced mortality than fish from the corresponding hatchery (Fig. 3). In contrast, juvenile fall chinook salmon from the nonurban estuary were not more susceptible to *V. anguillarum*-induced mortality than the fish from the corresponding hatchery. The results of these initial disease challenges indicate that, in juvenile chinook salmon from an urban estuary, contaminant-associated immunodysfunction appears to lead to increased susceptibility to pathogenesis by a virulent marine bacterium. Similar findings were reported by Servizi et al. (1993) for outmigrating juvenile chinook salmon in the Fraser River estuary. In their laboratory based study evaluating the toxic effects of bleached kraft mill effluents, they observed an increased prevalence of bacterial kidney disease (a chronic bacterial infection of salmonids) in juveniles following a 212-day study simulating exposure to pollutants found in the Fraser River.

Immunosuppression and the subsequent increased susceptibility to disease are not the only potential deadly effects of exposure to chemical contaminants in urban estuaries. Effects on neuronal function and subsequently on behavior have been reported in juvenile salmonids exposed to 2-(thio-cyanomethylthio) benzothiazole (TCMTB), an antisapstain fungicide used to protect freshly cut lumber. Exposure of juvenile chinook salmon to TCMTB at levels comparable to exposures occurring in the Fraser River estuary increased susceptibility to predation by a natural marine predator, yellowtail rockfish (*Sebastes flavidus*) (Kruzynski and Birtwell 1994). Although the mechanisms and the linkages between exposure and biological effects are not fully delineated, the performance-based assessment on survival potential is ecologically relevant. The implication to survival of juvenile salmon in an environment at times of high predator densities is indicated by the study of Beamish and Neville (1995) showing that the potential impact of predation by lamprey on juvenile chinook salmon in the Fraser River estuary plume may reduce by a large percentage (nearly 50%) the recruitment potential of hatchery fish to harvest. Thus, increasing the chemical contaminant burden in urban estuaries may have even greater implications to the survival of a stock already depressed.

The findings presented here strongly indicate that, in addition to the myriad anthropogenic factors that can affect the survival of outmigrating juvenile fall chinook salmon in fresh water, the biological effects of chemical contaminants on these fish during their residency in certain urban estuaries can also potentially lead to reduced survival. Concomitant with the increased chemical exposure, juvenile chinook salmon inhabiting certain urban estuaries exhibit evidence of impairment of physiological processes such as immune system alterations, impaired growth (not described here), and behavioral changes. The assessment of the long-term effects of physiological changes induced by chemical pollution in urban estuaries on selected salmon stocks can be placed into context by using performance-based evaluations of effects at the level of the organism (Fig. 4). Overall, the findings from these recent studies provide evidence of linkage between the presence of elevated levels of complex mixtures of chemical contaminants in polluted estuaries and effects on health and survival of juvenile chinook salmon. Additional research is clearly needed to address the large gaps in understanding concerning the effects of oceanic factors on salmon survival.

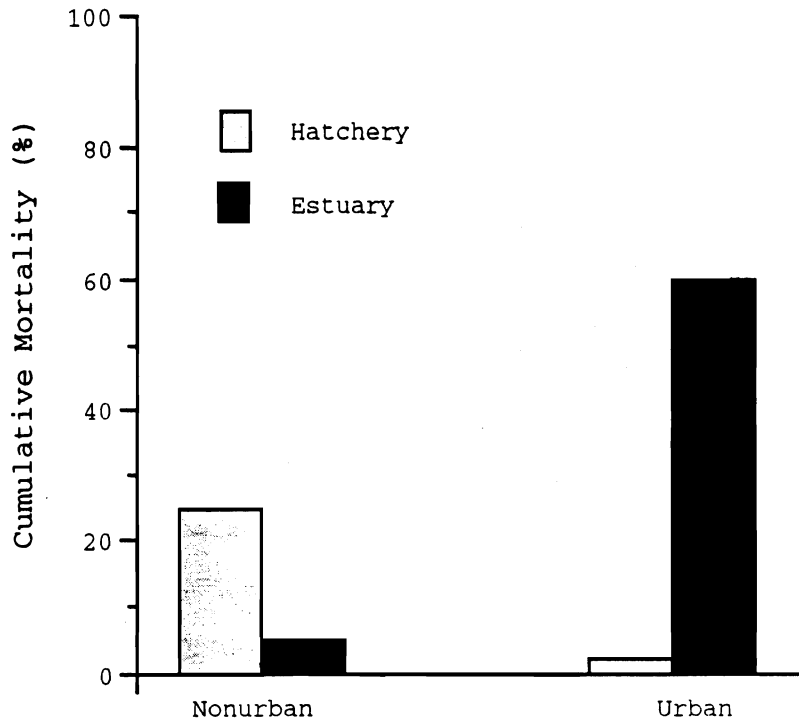

Figure 3. Percent cumulative mortality of juvenile chinook salmon from hatcheries and estuaries of a nonurban and urban river system from Puget Sound, Washington after 4 days exposure to *Vibrio anguillarum* (adapted from Arkoosh et al. in preparation).

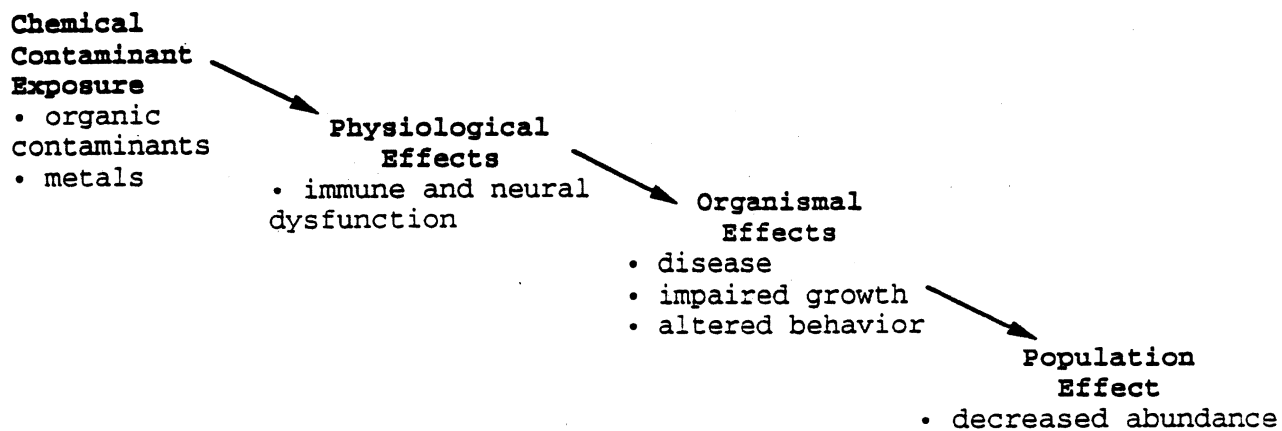

Figure 4. Conceptual model of relationships between toxic chemical exposure and population-level impacts in juvenile chinook salmon. Performance-based assessments, such as plaque-forming cell response (immune function), growth rate, disease challenge, and predator avoidance, are used to link physiological and organismal effects to potential population-level impacts.

However, this recent evidence suggesting that outmigrant juvenile fall chinook salmon are experiencing sublethal effects from toxic chemical exposure during their residence in urbanized estuaries indicates the need to further investigate estuarine pollution as a contributing factor to declines in salmon stocks from urbanized watersheds.

Citations

- Arkoosh, M. R., E. Casillas, E. Clemons, B. B. McCain, and U. Varanasi. 1991. Suppression of immunological memory in juvenile chinook salmon (*Oncorhynchus tshawytscha*) from an urban estuary. *Fish & Shellfish Immunol.* 1:261-277.
- Arkoosh, M. R., E. Casillas, P. Huffman, E. Clemons, J. Evered, J. E. Stein, and U. Varanasi. In prep. Increased susceptibility of juvenile chinook salmon (*Oncorhynchus tshawytscha*) from a contaminated estuary to the pathogen *Vibrio anguillarum*.
- Arkoosh, M. R., E. Clemons, M. Myers, and E. Casillas. 1994. Suppression of B-cell mediated immunity in juvenile chinook salmon (*Oncorhynchus tshawytscha*) after exposure to either a polycyclic aromatic hydrocarbon or to polychlorinated biphenyls. *Immunopharmacol. Immunotoxicol.* 16:293-314.
- Arkoosh, M. R., and S. L. Kaattari. 1987. Effect of early aflatoxin B₁ exposure on *in vivo* and *in vitro* antibody responses in rainbow trout, *Salmo gairdneri*. *J. Fish Biol.* 31(Supplement A):19-22.
- Beamish, R. J., and C-E. M. Neville. 1995. Pacific salmon and Pacific herring mortalities in the Fraser River plume caused by river lamprey (*Lampetra ayresi*). *Can. J. Fish. Aquat. Sci.* 52:644-650.
- Dean, J. H., J. B. Cornacoff, and M. I. Luster. 1990. Toxicity to the immune system: A review. In J. W. Hadden and A. Szentivanyi (editors), *Immunopharmacology reviews*, p. 377-410. Plenum Press, New York.
- Dean, J. H., M. J. Murray, and E. C. Ward. 1986. Toxic responses of the immune system. In C. D. Klassen, M. O. Amdur, and J. Doull (editors), *Casarett and Doull's Toxicology. The basic science of poisons*, p. 245-285. Macmillan, New York.
- Elliott, D. G., R. J. Pascho, and A. N. Palmisano. 1995. Brood stock segregation for the control of bacterial kidney disease can affect mortality of progeny chinook salmon (*Oncorhynchus tshawytscha*) in seawater. *Aquaculture* 132:133-144.

- Krahn, M. M., L. D. Rhodes, M. S. Myers, L. K. Moore, W. D. MacLeod, Jr., and D. C. Malins. 1986. Associations between metabolites of aromatic compounds in bile and the occurrence of hepatic lesions in English sole (*Parophrys vetulus*) from Puget Sound, Washington. *Arch. Environ. Contam. Toxicol.* 15:61-67
- Kruzynski, G. M., and I. K. Birtwell. 1994. A predation bioassay to quantify the ecological significance of sublethal responses of juvenile chinook salmon (*Oncorhynchus tshawytscha*) to the antisapstain fungicide TCMTB. *Can. J. Fish. Aquat. Sci.* 51:1780-1790.
- McCain, B. B., D. W. Brown, M. M. Krahn, M. S. Myers, R. C. Clark, Jr., S-L. Chan, and D. C. Malins. 1988. Marine pollution problems, North American West Coast. *Aquat. Toxicol.* 11:143-162.
- McCain, B. B., D. C. Malins, M. M. Krahn, D. W. Brown, W. D. Gronlund, L. K. Moore, and S-L. Chan. 1990. Uptake of aromatic and chlorinated hydrocarbons by juvenile chinook salmon (*Oncorhynchus tshawytscha*) in an urban estuary. *Arch. Environ. Contam. Toxicol.* 19:10-16.
- McLeay, D. J., and M. R. Gordon. 1977. Leucocrit: A simple hematological technique for measuring acute stress in salmonid fish, including stressful concentrations of pulp mill effluent. *Am. Fish. Soc. Symp.* 7:317-322.
- Rice, C. D., and B. A. Weeks. 1989. Influence of tributyltin on in vitro activation of oyster toadfish macrophages. *J. Aquat. Anim. Health.* 1:62-68.
- Servizi, J. A., R. W. Gordon, D. W. Martens, W. L. Lockhart, D. A. Metner, I. H. Rogers, J. R. McBride, and R. J. Norstrom. 1993. Effects of biotreated bleached kraft mill effluent on fingerling chinook salmon (*Oncorhynchus tshawytscha*). *Can. J. Fish. Aquat. Sci.* 50:846-857.
- Stein, J. E., T. Hom, T. K. Collier, D. W. Brown, and U. Varanasi. 1995. Contaminant exposure and biochemical effects in outmigrant juvenile chinook salmon from urban and nonurban estuaries of Puget Sound, Washington. *Environ. Toxicol. Chem.* 14:1019-1029.
- Thuvander, A. 1989. Cadmium exposure of rainbow trout, *Salmo gairdneri* Richardson: Effects of immune functions. *J. Fish Biol.* 35:521-529.
- Varanasi, U., J. E. Stein, and M. Nishimoto. 1989. Biotransformation and disposition of polycyclic aromatic hydrocarbons (PAH) in Fish. In U. Varanasi (editor), *Metabolism of polycyclic aromatic hydrocarbons in the aquatic environment*, p. 93-149. CRC Press, Boca Raton, Florida.

Ward, E. C., M. J. Murray, and J. H. Dean. 1985. Immunotoxicity of nonhalogenated polycyclic aromatic hydrocarbons. *In* J. H. Dean, M. I. Luster, A. E. Munson, and H. Amos (editors), *Immunotoxicology and immunopharmacology*, p. 291-303. Raven Press, New York.





Process and Mechanisms--Nearshore Coastal



FACTORS INFLUENCING THE MARINE SURVIVAL OF PINK SALMON
IN PRINCE WILLIAM SOUND, ALASKA

Robert T. Cooney and T. Mark Willette

Institute of Marine Science
University of Alaska Fairbanks
Fairbanks, AK 99775-1080

and

Alaska Department of Fish and Game
Cordova, AK 99574

Pink salmon (*Oncorhynchus gorbuscha*) are the most abundant of the five Pacific salmon species in Alaska (Rogers 1986). Wild stocks in Prince William Sound have historically demonstrated negligible odd-even year cycle dominance, although other, longer term trends are evident since 1960 (Fig. 1). Adult returns of less than 10 million fish per year increased to nearly 20 million fish in 1979 and for several years following, but returned to lower production levels in 1986. Since that time, only the returns in 1990, 1991, and 1994 have approached or surpassed 10 million fish. Similar decadal-level production cycling has been described for salmonids in Alaska (Hare and Francis 1995).

A large ocean-ranching program for pink salmon was initiated in 1977. Growing hatchery capacity drove increasingly larger releases of juveniles that peaked in 1991 at 616 million fry. Since 1987, hatchery-released rather than wild pink salmon have been the numerically dominant stock in Prince William Sound. Annual percent marine survivals for hatchery fry to adults have ranged between 1.0 and 9.8, and average 4.4 (Alaska Department of Fish and Game, unpublished). Two of the three poorest production years were recent: 1992 and 1993. There is concern that a hatchery program of this size is seriously impacting the wild production in the region, although direct negative effects have not been demonstrated. An elaborately phased fishery attempts to separate harvests on wild and hatchery stocks as the means to protect the wild escapement each year.

Alaska Department of Fish and Game has censused pre-emergent fry populations since 1962 in index streams in Prince William Sound. These measures generally predict adult returns and have been used as the principal area forecast tools for wild stocks. When the wild return per fry density (a proxy for marine survival) is compared with hatchery marine survivals beginning in 1977, it is apparent that years of good, average, or poor survivals are phased similarly (Fig. 2). This relationship supports a contention that common marine factors influence the survival of both populations.

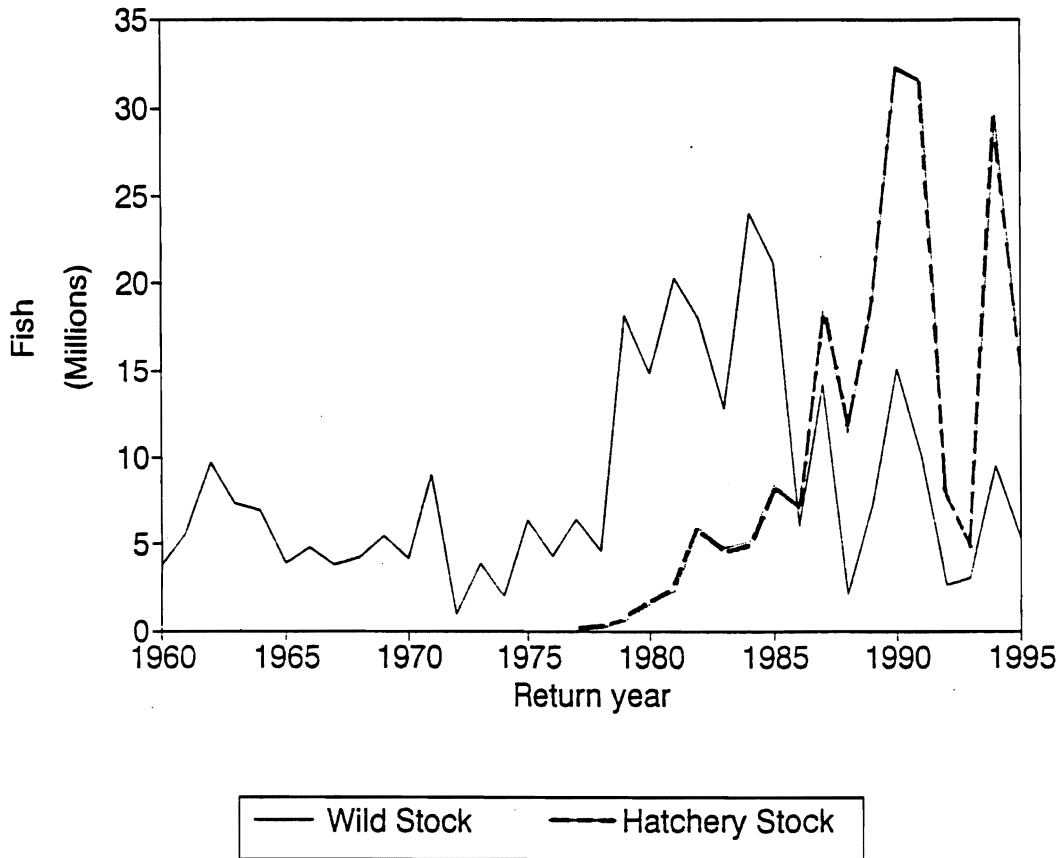

Figure 1. Historical adult returns of wild and hatchery released pink salmon in Prince William Sound, Alaska.

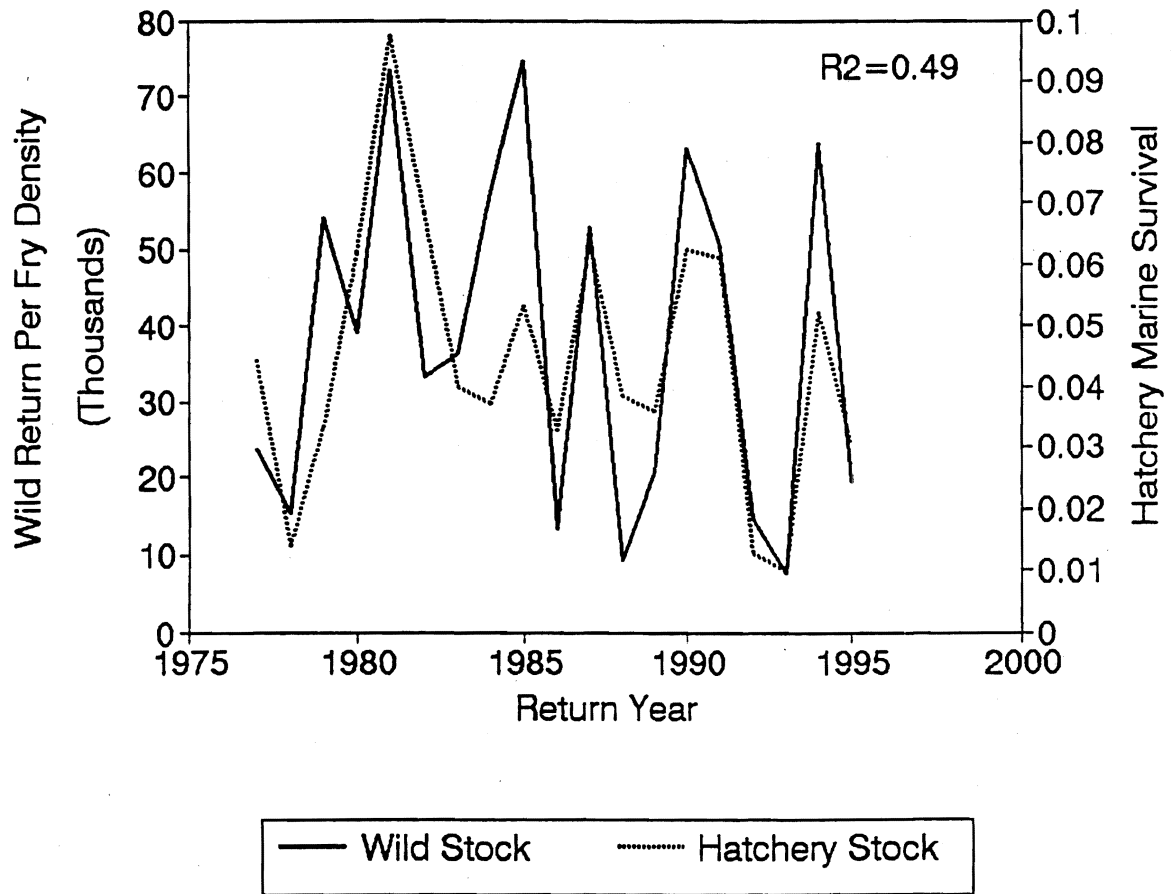

Figure 2. Comparisons between wild and hatchery marine survivals for pink salmon in Prince William Sound, Alaska.

The salmon literature suggests that pink salmon run strength is established each year during early marine residence, perhaps during the first few weeks in the coastal ocean (Parker 1971, Hartt 1980, Healey 1982, Bax 1983, Hargreaves and LeBrasseur 1985). The mechanism for loss is believed to be predation, and the rate of loss is thought to be modified by the growth rate of the fry during this critical period. The slowest growing fish probably experience the highest rates of mortality since they remain at risk longer in the smallest, presumably weakest, life stages. Temperature and food have been implicated as the major factors influencing growth rates (Walters et al. 1978, Mortensen 1983, Healey 1991). Locally, Willette (1985) and Willette and Cooney (1991) found that production levels of odd and even year southcentral Alaska pink salmon stocks are sensitive to fry-year spring-time ocean temperatures, and that the odd brood lines are also influenced by ocean temperatures during the late maturing and adult stages.

Wild juvenile pink salmon in the northern Gulf of Alaska begin emerging into the nearshore tidally mixed zone in late March. The outmigration from natal habitats is usually completed by early June (Taylor 1988). Cooney et al. (1995) demonstrated close correspondence between the timing of wild juvenile pink salmon ocean entry and the timing and duration of a coastal springtime zooplankton bloom in Prince William Sound. This correspondence suggested that fry benefit by emerging during this period. In fact, marine survival estimates from the hatchery program demonstrate that fry released into the bloom perform better than fry released prior to, or after, the peak of zooplankton biomass. Until recently, this observation seemed to confirm food-limited growth dependence for fry, since juvenile pink salmon are immediate consumers of pelagic food in the deep, nearshore waters of the region (Urquhart 1979). However, more recent studies (Willette in press) demonstrate pink salmon fry growth rates (determined from post-release recaptures of wire-tagged fry) are predicted by springtime temperatures, but not by levels of food. This surprising result means that either zooplankton is rarely growth-rate limiting for fry, or that plankton plays some yet-to-be-determined role in modifying hatchery and, presumably, wild stock production.

In 1993, after a week-long blockade of the Alyeska Pipeline Terminal in Port Valdez by fishermen concerned over failing pink salmon and herring production following the *Exxon Valdez* oil spill, out-of-court settlement funds were made available to pursue ecosystem-level studies of the early life stages of these two commercial species. In April 1994, the Sound Ecosystem Assessment (SEA) program began the first of five intensive years of field and modeling studies. The SEA program attempts a combined bottom-up and top-down approach to describe factors constraining juvenile pink salmon (and herring) survival. The research focus is on oceanographically modified predation loss as the principal factor regulating pink salmon survival in the juvenile stages each year. Mechanisms influencing fry survival are being used to create a series of physical and biological models envisioned as the major research products of the work, and as carry-forward tools for more informed management of Prince William Sound's pink salmon populations.

In developing its program, SEA began with a simple carbon budget for the region. Given previous estimates of primary productivity, and adopting accepted transfer efficiencies,

carbon fixed by phytoplankton was distributed to zooplankton and higher consumers. Enough was understood about the growth of juvenile salmon so their forage demand could be computed on the basis of observed growth rates (Cooney 1993). This surprisingly small demand was then increased by a factor of 10 to estimate the consumption for all 0-age fish in the system, including Pacific herring (*Clupea pallasii*), northern smoothtongue (*Leuroglossus schmidti*), and walleye pollock (*Theragra chalcogramma*). The remaining carbon was distributed to older juvenile fishes and apex consumers, including adult fish, birds, and marine mammals (Fig. 3).

The carbon budget suggests that zooplankton should support large populations of consumers, and that the region may also serve as a juvenile fish nursery. The model further suggests that when zooplankton stocks are low--seasonally or annually--intermediate and large-size consumers can augment their diets by eating more smaller fishes. Since the subarctic surface zooplankton community is greatly diminished during the fall and winter months, the pelagic system is probably more planktivorous during the spring and summer months, and piscivorous during much of the remainder of the year. The present research program focuses on the role that zooplankton and other factors play in modifying losses of juvenile salmon to predators during the critical first few weeks of early marine residence. Field studies take advantage of large fry releases from hatcheries to observe and measure local predation losses on timescales of days to weeks during a sampling period from April through mid-June.

After 2 years of study, the SEA program has begun to assemble an understanding of processes regulating the survival of wild and hatchery released juvenile pink salmon. Fry predator studies have demonstrated that birds (principally kittiwakes) and walleye pollock play a major role in fry losses each year. Personnel of local hatcheries have been aware of bird and pollock predation, but they have never attempted a quantitative assessment of the annual impact. Midwater trawling and acoustic surveys conducted near hatcheries in western Prince William Sound during the spring and summer of 1994 and 1995 established that adult pollock from a successful 1988 year class were the most dominant members of the nearsurface large-fish community from late April through early July. In April and May, a significant percentage of the diet of these fish was zooplankton; calanoid copepods were dominant and represented mostly by *Neocalanus* spp. During both 1994 and 1995, large numbers of calanoids occurred concurrently in the water column and stomachs of the walleye pollock. In both years, the consumption of 0-age fishes, including juvenile salmon, declined or remained at low levels in pollock diets during the copepod bloom (Fig. 4). Since wild and hatchery stocks of juvenile salmon migrate across deep water each year as they move southward in the region, offshore losses to adult pollock are probably modified by amounts of zooplankton present at this time.

In addition to salmon fry being vulnerable to adult walleye pollock over the deeper passages, more recent results suggest that in late May and early June of some years, 1- and 2-year-old pollock move into nearshore tidally mixed zones to feed. This is a time when most fry have grown to 50-70 mm in size and are leaving the shallow waters. Stomach analyses

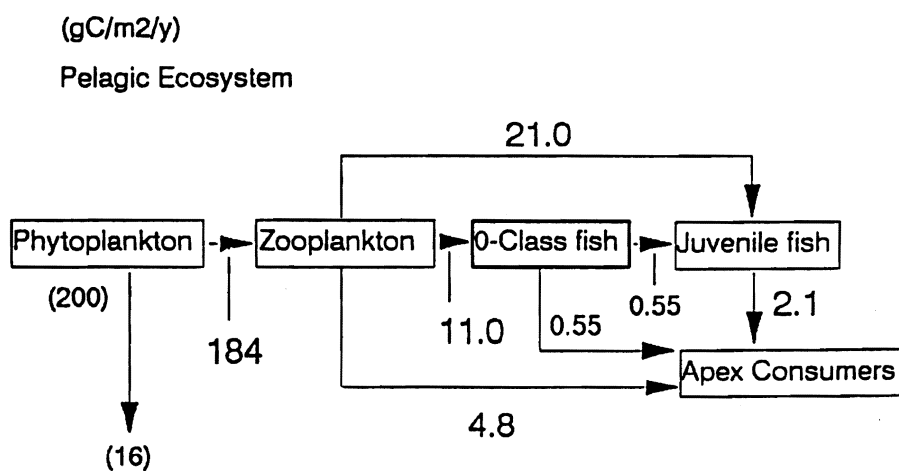

Figure 3. A generalized annual carbon budget for the pelagic ecosystem of Prince William Sound, Alaska.

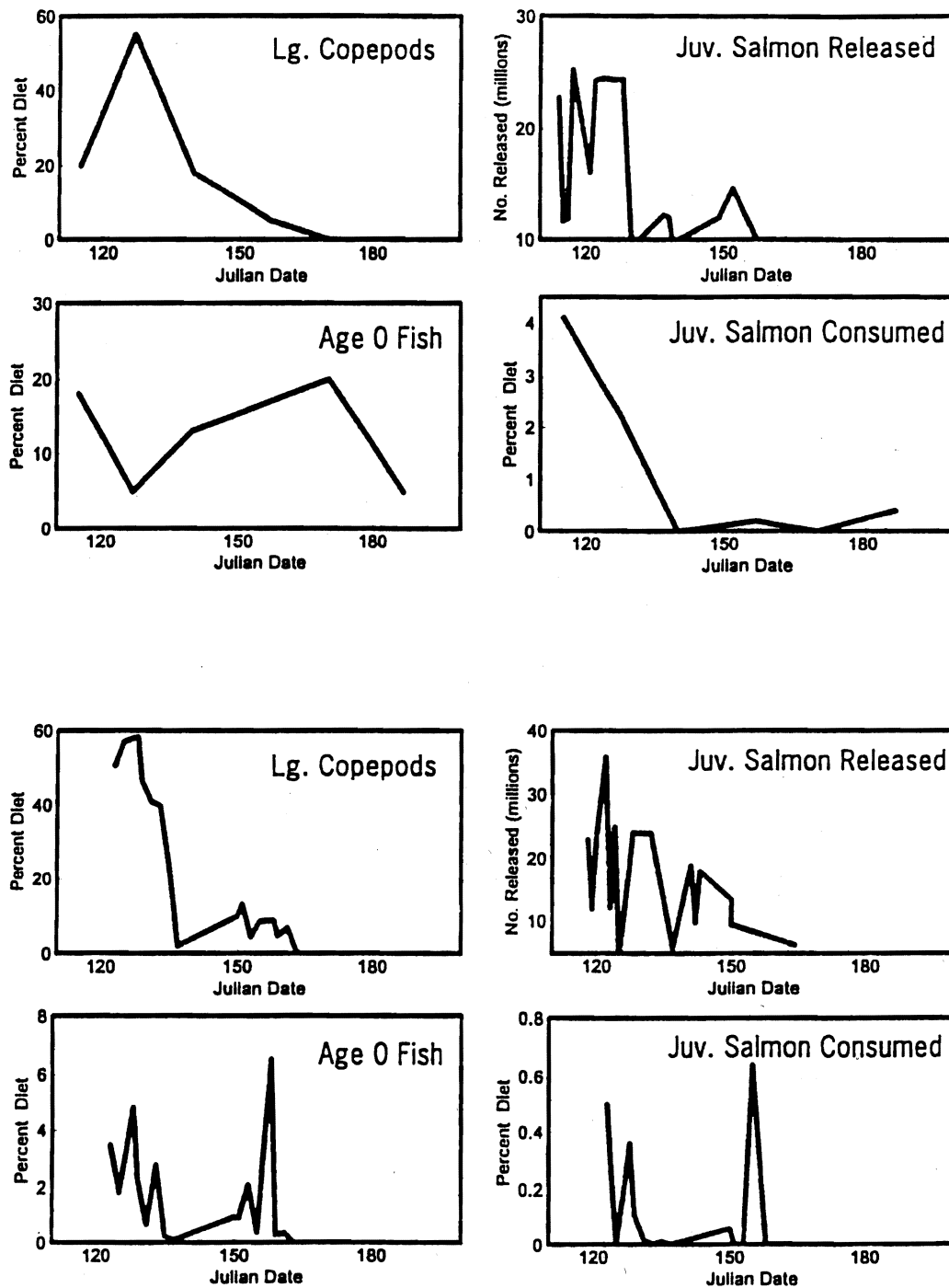

Figure 4. Adult walleye pollock stomach contents illustrating a time-series of large calanoid copepods, age-0 fish, and juvenile salmon. The releases of pink salmon from a nearby hatchery are also shown. The upper set is 1994, the lower, 1995.

indicate that some juvenile pollock feed heavily on salmon fry. Depending on the time phasing and numbers of each year, these late-arriving predators could account for substantial losses of juvenile pink salmon, particularly during years when reduced fry growth may extend their nearshore nursery period. The significance of fry size in relation to predation was examined in 1994 by experimentally releasing some fry that had been grown to over 1-g live weight. These fish, approximately four times larger than fry normally released from hatcheries, exhibited marine survivals an order of magnitude higher than their smaller surviving siblings (Table 1).

Other predators, including adult herring, squid, greenling (*Hexagrammos* spp.), Dolly Varden trout (*Salvelinus malma*), and adult salmon, also prey on juvenile salmon. With the possible exception of squid, these other predators seem to play a lesser predation role than walleye pollock. Unfortunately, there are problems associated with quantitatively sampling most of these other species. Squid are probably not taken adequately in trawls or fixed gear, and the nearshore regime cannot be fished with trawls because of the steep and rocky local topography. Seines, gill nets, and traps are providing some qualitative data, and side-scan sonar may help in the future.

Surprisingly, the monthly tidal cycle is also implicated in the survival of juvenile salmon. Survival is better under spring-tide rather than neap-tide conditions (Fig. 5). Observations this past year also demonstrate that catches of adult pollock were statistically correlated with tidal state. At the height of a mid-May spring-tide series, adults left the upper layers only to reappear later as the spring cycle relaxed (Fig. 6). We surmise that increased currents and turbulence associated with larger tidal lenses cause fish populations to reorient their distributions, and that feeding may be curtailed during these times.

In summary, a combined oceanographic and fisheries study in Prince William Sound is beginning to describe factors that interact to modify predation losses in juvenile salmon populations each year. Generally, pink salmon seem to have evolved a life history strategy that brings the juveniles into marine waters during an intense period of plankton growth each spring. This timing--on average--provides forage and seasonally warming temperatures that probably stimulate critical early season growth rates. The presence of immense upper-layer calanoid populations also provides food for most other consumers during this same time. Many fish and birds that eat fry find energy in abundant plankton populations as well. For any given year, the time-space phasing of fry, plankton, and consumer fish and bird populations, together with ocean temperatures, probably establish the conditions that modify predation on juvenile pink salmon. Warm years with high zooplankton stocks should enhance survival of rapidly growing fry that escape predation because most of the energy flowing to larger fishes, birds, and mammals comes from plankton. In contrast, cold years with reduced plankton biomass should be disastrous to fry whose growth rates would be reduced and who would be preyed upon more heavily by larger consumers unable to obtain sufficient energy from plankton. These extreme examples occur in the historical salmon record. However, there are enough years when fry growth rate and plankton sheltering alone fail to predict production to negate the applications of just this information.

Table 1. Marine survivals for hatchery pink salmon by release size and date for two hatcheries in Prince William Sound, 1994.

Hatchery	Release date	Total length (mm)	Release (millions)	Survival (%)
A.F.K.	Early May	30	84.8	0.4
A.F.K.	Early June	50	7.0	7.2
W.H.N.	Early May	33	154.7	0.4
W.H.N.	Early June	55	7.7	22.1

A.F.K. = Armin F. Koernig Hatchery.

W.H.N. = Wallace H. Noerenberg Hatchery.

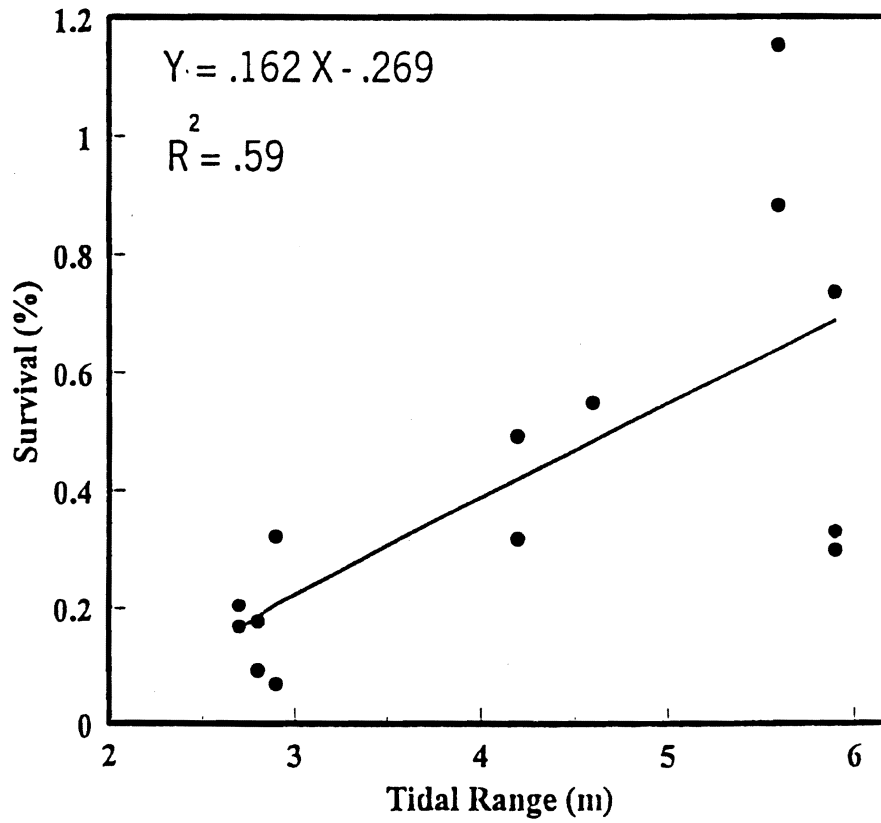

Figure 5. Percent marine survival for fry released at different stages of the monthly tidal cycle during April and May 1994 and returning as adults in 1995.

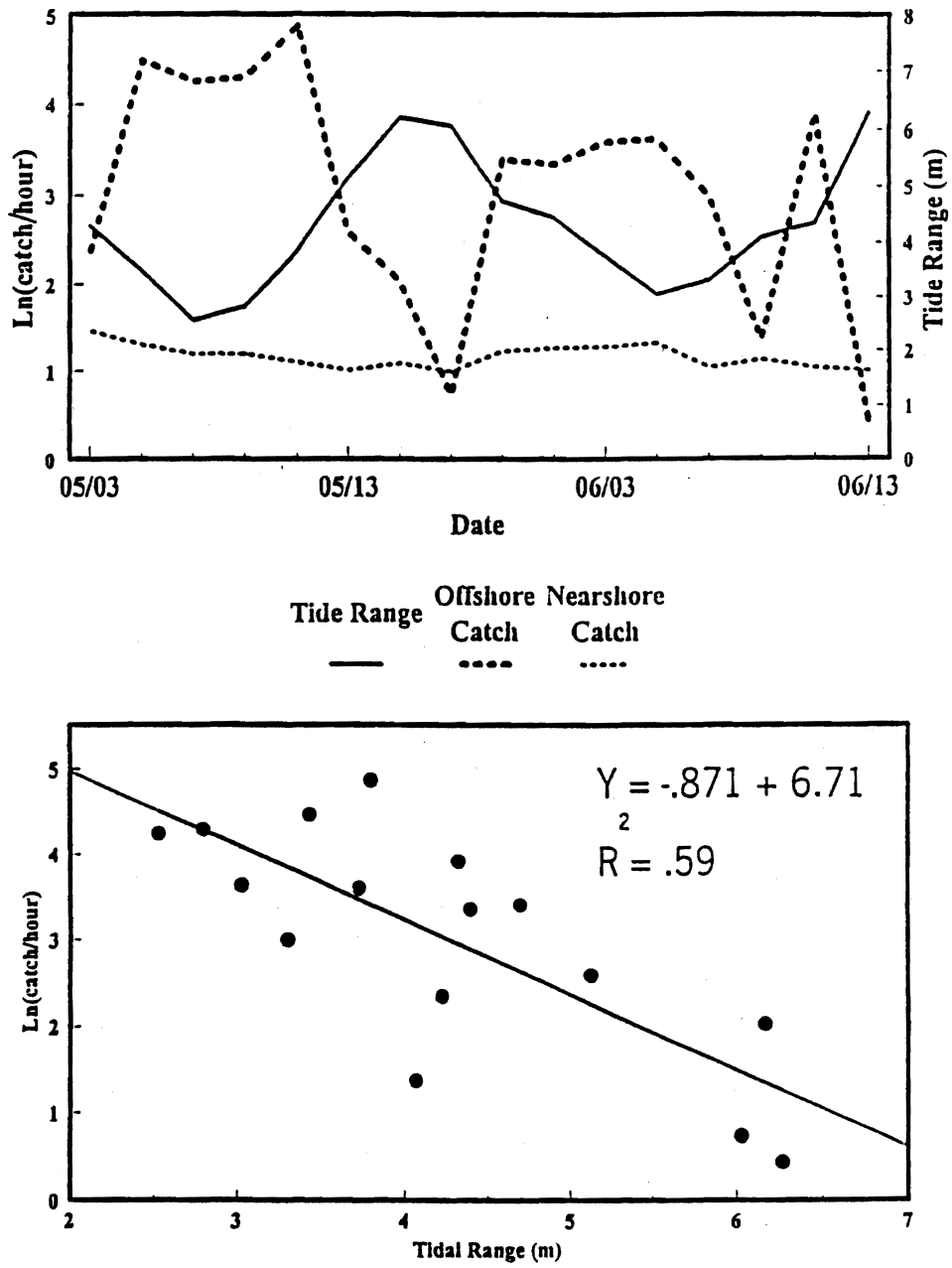

Figure 6. A time-series of catch, and the relationship between tidal range and catch, of adult walleye pollock in April, May, and June 1995.

Because of inherent system complexities, it is unlikely that our overall results will ever lend themselves to highly accurate survival estimates of pink salmon based on fry year growth conditions and predation loss factors. However, we do expect that simulations of major parts of the system will provide reasonably consistent projections of good, average, or poor marine survivals one year in advance of adult returns. This consistency is presently lacking in forecasts of pink salmon in Prince William Sound, to the detriment of local harvest-management and enhancement programs.

To accomplish this goal, the SEA program is proposing a nominally funded long-term monitoring program to reinitialize the model(s) for selected bottom-up forcing (temperature, winds, fresh water, other), for validation purposes, and to index, rather than predict, predator populations each year. The SEA program is expected to complete by 1997 much of the modeling and to have a working, constantly updated, forecasting model running by 1999.

Citations

- Bax, N. J. 1983. Early marine mortality of marked juvenile chum salmon (*Oncorhynchus keta*) released into Hood Canal, Puget Sound, Washington, in 1980. *Can. J. Fish. Aquat. Sci.* 40:426-435.
- Cooney, R. T. 1993. A theoretical evaluation of the carrying capacity of Prince William Sound, Alaska, for juvenile Pacific salmon. *Fish. Res.* 18:77-87.
- Cooney, R. T., T. M. Willette, S. Sharr, D. Sharp, and J. Olsen. 1995. The effect of climate on North Pacific pink salmon (*Oncorhynchus gorbuscha*) production: Examining some details of a natural experiment. *In* R. J. Beamish (editor), *Climate change and northern fish populations*. *Can. Spec. Publ. Fish. Aquat. Sci.* 121:475-482.
- Hare, S. R., and R. C. Francis. 1995. Climate change and salmon production in the Northeast Pacific Ocean. *In* R. J. Beamish (editor), *Climate change and northern fish populations*. *Can. Spec. Publ. Fish. Aquat. Sci.* 121:357-372.
- Hargreaves, N. B., and R. J. LeBrassuer. 1985. Species selective predation on juvenile pink salmon (*Oncorhynchus gorbuscha*) and chum salmon (*O. keta*) by coho salmon (*O. kisutch*). *Can. J. Fish. Aquat. Sci.* 42:659-668.
- Hartt, A. C. 1980. Juvenile salmon in the oceanic ecosystem--the critical first summer. *In* W. J. McNeil and D. C. Himsforth (editors), *Salmonid ecosystems of the North Pacific*. Oregon State University Press, Corvallis, p. 25-57.
- Healey, M. C. 1982. Timing and relative intensity of size-selective mortality of juvenile chum salmon (*Oncorhynchus keta*) during early sea life. *Can. J. Fish. Aquat. Sci.* 39:952-957.

- Healey, M. C. 1991. Diets and feeding rates of juvenile pink, chum and sockeye salmon in Hecate Strait, British Columbia. *Trans. Am. Fish. Soc.* 120:303-318.
- Mortensen, D. G. 1983. Laboratory studies on factors influencing the first feeding of newly emerged pink salmon (*Oncorhynchus gorbuscha*) fry. M.S. Thesis, 108 p. Univ. Alaska, Juneau.
- Parker, R. R. 1971. Size selective predation among juvenile salmonid fishes in a British Columbia inlet. *J. Fish. Res. Board Can.* 28:1503-1510.
- Rogers, D. E. 1986. Pacific salmon. In D. W. Hood and S. T. Zimmerman (editors), *The Gulf of Alaska: Physical environment and biological resources*. U.S. Dep. Comm., NOAA, Environ. Res. Lab., p. 461-478. (Available from Arctic Environ. Assess. Cent., 222 W. 8th Ave., No. 56, Anchorage, AK 99513.)
- Taylor, S. G. 1988. Inter- and intra-annual survival of pink salmon (*Oncorhynchus gorbuscha*) returning to Auke Creek, Alaska in 1986 and 1987. APPRISE Annual Report 1987. School of Fisheries and Ocean Sciences, Univ. Alaska, Fairbanks, Tech. Rep. 1:547-571.
- Urquhart, D. L. 1979. The feeding, movement, and growth of pink salmon (*Oncorhynchus gorbuscha*) fry released from a hatchery in Prince William Sound, Alaska. M.S. Thesis, Univ. Alaska, Fairbanks, 111 p.
- Walters, C. J., J. Holborn, R. M. Peterman, and M. J. Staley. 1978. Model for examining early ocean limitation on Pacific salmon production. *J. Fish. Res. Board Can.* 35:1303-1315.
- Willette, T. M. 1985. The effects of ocean temperatures on the survival of odd- and even year pink salmon (*Oncorhynchus gorbuscha*) populations originating from Prince William Sound, Alaska. M.S. Thesis, Univ. Alaska, Fairbanks, 115 p.
- Willette, T. M. In press. Impacts of the Exxon Valdez oil spill on the migration, growth and survival of juvenile pink salmon in Prince William Sound, Alaska. Proceedings of EVOS Symposium, Feb. 1993, Anchorage, Alaska.
- Willette, T. M., and R. T. Cooney. 1991. An empirical orthogonal functions analysis of sea surface temperature anomalies in the North Pacific Ocean and cross correlations with pink salmon (*Oncorhynchus gorbuscha*) returns to southern Alaska. In B. White and I. Guthrie (editors), *Proceedings of 15th Pink and Chum Salmon Workshop*. Pacific Salmon Commission, p. 111-121. (Available from Pacific Salmon Commission, 600-1155 Robson St., Vancouver, BC, Canada V6E 1B9.)



THE IMPORTANCE OF VARIOUS SPATIAL AND TEMPORAL SCALES IN THE INTERACTION OF JUVENILE SALMON AND THE MARINE ENVIRONMENT

Richard D. Brodeur

Alaska Fisheries Science Center
National Marine Fisheries Service
7600 Sand Point Way NE
Seattle, WA 98115-0070

Physical and biological oceanographers have long recognized the various scales of spatial and temporal variability affecting ecological processes in the ocean (Denman and Powell 1984, Legendre and Demers 1984, Hauray and Pieper 1987, Steele 1978, Mann and Lazier 1991, Dickey 1990). The purpose of this paper is to examine several of the spatial and temporal scales of variability that Pacific salmon (*Oncorhynchus* spp.) are exposed to during their early life in the ocean, and discuss how these may specifically affect the feeding ecology of these juveniles. The scales of variability encountered by an individual salmon may be broad in terms of spatial extent, from those affecting the few meters immediately nearby to those affecting much of the Pacific basin. Similarly, processes that occur on temporal scales ranging from a few minutes to several decades may be important. Some of the spatial and temporal scales of variability that may be important to the feeding of juvenile salmon are shown in Figure 1.

It is beyond the scope of this paper to examine in detail all of these physical factors. I will instead focus on three of these which may be particularly important. Included among these are long-term interannual cycles of variability which may be affected, such as that seen for El Niño events, by physical forcing mechanisms initiated well beyond the waters of the Pacific Northwest. I will also look at a mesoscale feature, such as the dynamics of the Columbia River plume, which may be important for only a few months and in only part of the oceanic range of a salmon species. Finally, I will examine small-scale features, such as Langmuir circulation cells and internal waves, and suggest how these may also be important to the feeding ecology of juvenile salmon.

Large-Scale Variability

Long time series, extending, for example, back to the early part of the century, are now available for several environmental and biological variables in the North Pacific (e.g., Beamish 1995). Several areas, notably the California Cooperative Oceanic Fisheries Investigations grid and Ocean Station P, have been intensely studied for several decades and provide some measure of the interannual variability occurring on a local scale (Brodeur et al. 1996). Superimposed upon this shorter term interannual variability is the longer scale environmental variability associated, for instance, with the El Niño/Southern Oscillation

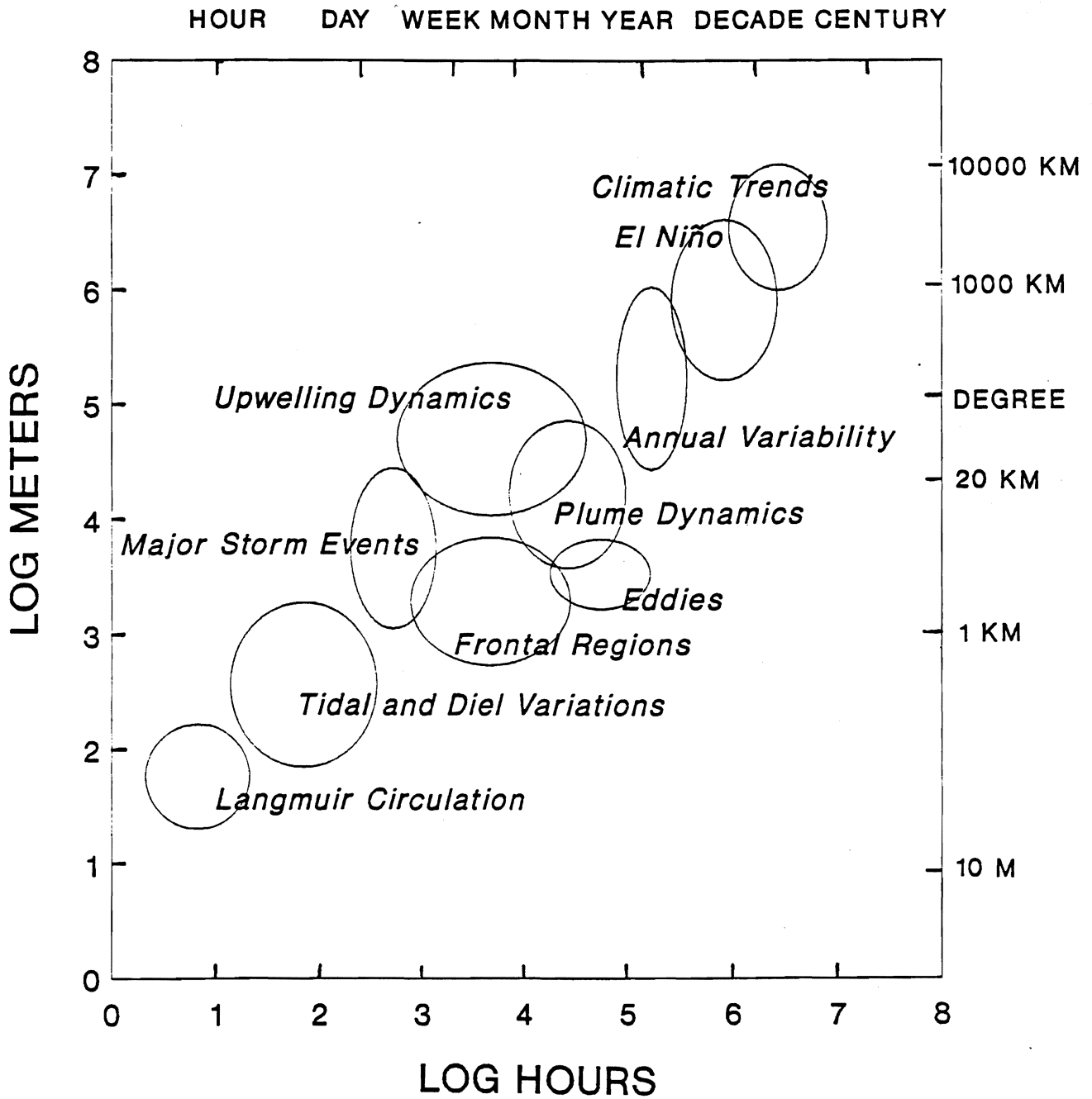

Figure 1. Time and space scales of physical variability in the ocean environment which may affect juvenile salmon.

(ENSO) phenomenon. Although ENSO warming events are known to occur on the order of every 3-4 years, it is only every 25 years on average when an event is of sufficient strength to affect high latitude ecosystems. An event occurring during 1982-83 was one of the strongest and best documented on record (Mysak 1986, Pearcy and Schoener 1987) and had substantial negative impacts on adult salmon production (Pearcy et al. 1985, Mysak 1986, Johnson 1988). I will present some possible ways in which an ENSO event may affect juvenile salmon feeding and subsequent survival.

One of the most direct ways in which an El Niño may affect salmon may be in the suppression of normal upwelling conditions in coastal waters. Several studies have shown a strong relationship between the survival and growth of coho salmon (*Oncorhynchus kisutch*) and the upwelling intensity when they first entered the ocean (Scarnecchia 1981, Nickelson 1986, Fisher and Pearcy 1988). For example, mean monthly Bakun upwelling indices were far below normal during the summer of 1983, resulting in high surface temperatures and low chlorophyll *a* concentrations along much of the West Coast (Fiedler 1984, Brodeur and Pearcy 1992). Even when upwelling conditions were favorable, a strong and deep thermocline, caused by onshore and northward advection of warm water, prevented normal mixing and resulted in warm, nutrient-poor water being upwelled to the surface (Huyer and Smith 1985).

The reduced upwelling may have greatly affected the entire pelagic ecosystem off Oregon and Washington, resulting in less overall food and a shift in the diets of most pelagic predators, including juvenile and adult salmon, to less preferred prey items (Brodeur and Pearcy 1990, 1992). Although the mean stomach fullness of juvenile salmon was not significantly different than in other non-Niño years (Brodeur 1992), the prey composition was radically different, consisting of smaller and probably less nutritious zooplankton species instead of the euphausiids and larval and juvenile fishes normally consumed by juvenile salmon (Pearcy et al. 1985, Brodeur and Pearcy 1990). As Fulton and LeBrasseur (1985) have shown, a major northward shift in the Subarctic Boundary occurs during strong ENSO events (Fig. 2), which results in a smaller prey-size spectrum of available food organisms, which may not be used as efficiently by juvenile salmon.

Other ways in which an ENSO warming event may influence survival of salmon is by changing their migration and distribution patterns, making them more available or susceptible to predators (Mysak 1986). The intrusion of warm oligotrophic waters onto the shelf may limit the distribution of salmon to a much narrower nearshore zone. If the offshore abundance of alternate prey species is also reduced during an El Niño year, the concentrations of juveniles may attract avian and piscine predators (Pearcy 1988). A decrease in mean growth rate expected under low productivity would potentially increase the probability of salmon being consumed by a size-selective predator (Healey 1982).

Furthermore, if concentrations of prey resources are much lower, the salmon must expend a much greater amount of time searching for food at a greater energy expenditure while being able to spend less time avoiding predators. The higher temperatures also necessitate higher rations to sustain the increased metabolic rates. Juvenile coho and chinook

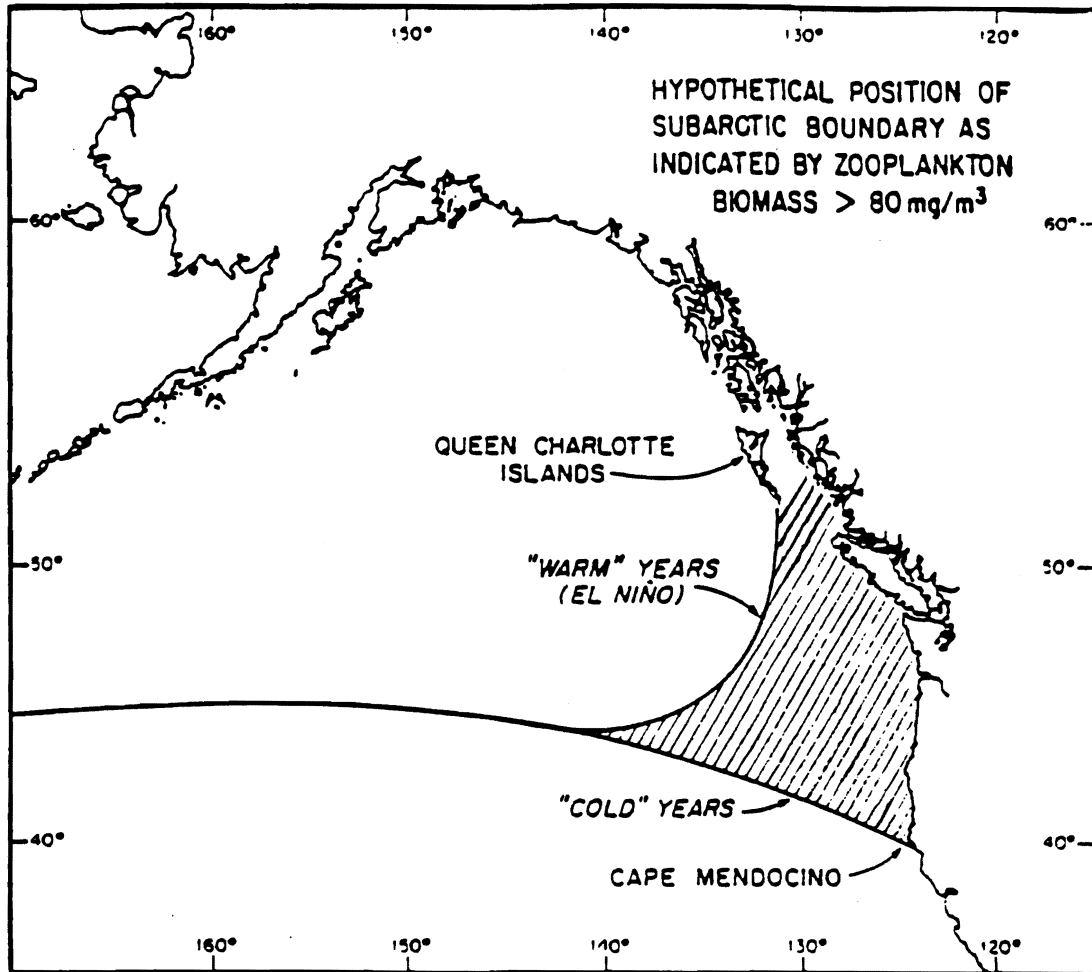

Figure 2. Interannual shifting of the Subarctic Boundary during warm and cold years (from Fulton and LeBrasseur 1985).

salmon (*O. tshawytscha*) food consumption during 1983, based on bioenergetic modeling estimates, indicated that both species were food limited due to the higher rations and decreased food availability during ENSO conditions (Brodeur et al. 1992). During normal years, there appeared to be adequate food for juvenile salmon survival.

Mesoscale Variability

An example of a mesoscale feature affecting mainly Oregon and Washington coastal waters and lasting several months is the dynamic nature of the Columbia River plume. At the height of its development, this oceanic extension of the Columbia River extends well offshore and south to off central Oregon. According to Barnes et al. (1972), its outer boundary is delimited by the 32.5‰ isohaline. During the winter, the outflow from the Columbia River is much weaker and the winds are from the southwest which pushes the plume onto the Washington coast. During a period called the spring transition in April-May, the prevailing wind pattern switches to northerly winds and the plume moves south. The winds also promote inshore coastal upwelling which pushes the plume well offshore (Fig. 3), although the shape and orientation of the plume can be variable during the summer (Fiedler and Laurs 1990). During the period of maximum runoff, the equivalent height of fresh water averages about 1 m (Barnes et al. 1972).

There is some evidence that juvenile coho salmon originating from the Columbia River utilize the plume as a transitional "habitat" between the brackish estuary and high salinity oceanic water. Marked juveniles caught at sea appear to follow the plume southward, travelling at about the same speed as the alongshore currents (Pearcy and Fisher 1988). It is only late in the summer or during poor upwelling years when the plume breaks down that juvenile coho begin to move northward. The timing of events also appears to be important. There appears to be a strong relationship between the date of the spring transition and the subsequent survival of the year class of coho salmon (Zirges 1981). Presumably, fish which enter the ocean before or shortly after the transition encounter a turbulent and highly saline environment, whereas later migrants that enter into a well-developed plume would enter a relatively benign environment and could gradually adjust to oceanic conditions. Riverine plumes also tend to have higher concentrations of zooplankton prey relative to adjacent marine waters, especially along the plume frontal region, which may attract juvenile salmon (St. John et al. 1992).

The date of transition can be variable on an interannual basis, extending from late January to May. The approximate timing of this transition can be deduced by examining for abrupt changes in the daily Bakun upwelling index or sea level, although in some years the transition is not well demarcated using these methods. A direct although costly method would be to examine moored surface current-meter data. An alternate method might be to use satellite temperature and ocean color imagery which can delineate the plume from adjacent upwelling and oceanic water (Pearcy and Keene 1974, Fiedler and Laurs 1990). The use of satellites may be an important tool for future salmon fisheries managers (Fiedler et al. 1984).

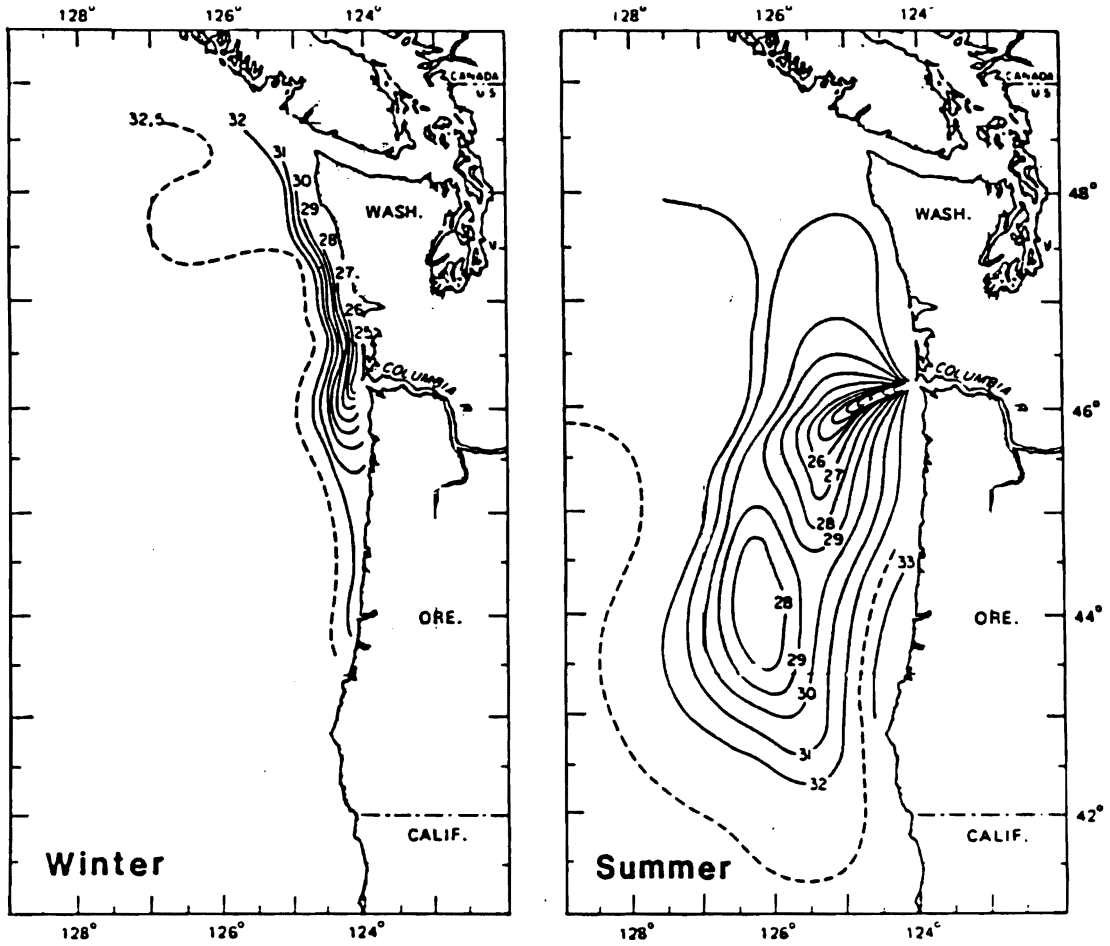

Figure 3. Seasonal variation in the location of the Columbia River plume (from Barnes et al. 1972). The plume is delimited by a dashed line in the figures.

In addition to the initial effects that the timing of the transition date has on the survival of salmon, the date of the transition between winter and summer regimes appears to be inversely related to the total cumulative upwelling occurring during any particular summer (Fig. 4). Although the long-term mean discharge of the Columbia River appears to be relatively constant, there has been a decrease over the last several decades in the volume of water exiting the Columbia River during peak outflow periods (Fig. 5) which may affect the thickness and offshore extent of the plume. The Fraser River system, which has less hydroelectric development and agricultural diversions than the Columbia River system, does not show a similar decrease in peak flow (Fig. 5). It is uncertain whether climatic-scale changes in precipitation patterns or anthropogenic changes (water storage and irrigation) is the main cause of this decrease, but it may possibly have serious consequences for salmon production in the Columbia River.

Small-Scale Variability

Small-scale variability refers to processes that may last only hours or even minutes and may affect the immediate surroundings of an individual juvenile salmon. Two such processes affecting surface waters are wind-driven vortical circulation such as Langmuir cells (Barstow 1983) and wave packets formed by internal waves (Owen 1981). Both of these processes form long rows of aggregated materials evident as slicks on the surface; the main difference being that the Langmuir cells are oriented in the direction of the wind while the internal waves do not necessarily have to be (Fig. 6). Because of their circulation patterns, both these processes have been shown to concentrate zooplankton in the neuston layer at densities several orders of magnitude above the surrounding surface and subsurface waters (Shanks and Wright 1987, Shenker 1988), which may in turn attract juvenile fish which feed on these concentrations (Kingsford and Choat 1986).

I have hypothesized (Brodeur 1989) that foraging juvenile salmon may utilize these food concentrations to some degree to minimize the search area needed to satisfy their daily energy requirements. The species composition found in neuston net tows bears a distinct similarity to those found in the stomachs of juvenile coho salmon. Some major food items, such as crab megalopae, are found in such high abundances in these aggregations that they may be visible from the deck of a ship (Shenker 1988). There is evidence that coho salmon reside in the upper 2 m of the water column at night (Pearcy and Fisher 1988) and may take advantage of these prey patches while minimizing predation upon themselves by visual surface predators such as seabirds. The dynamics of small-scale wind and wave motions may thus be linked to the feeding and hence survival of these juveniles.

Other Processes

Physical processes that occur on many different scales of variability appear to be important to the ecology of juvenile coho salmon. In addition to the three factors that are

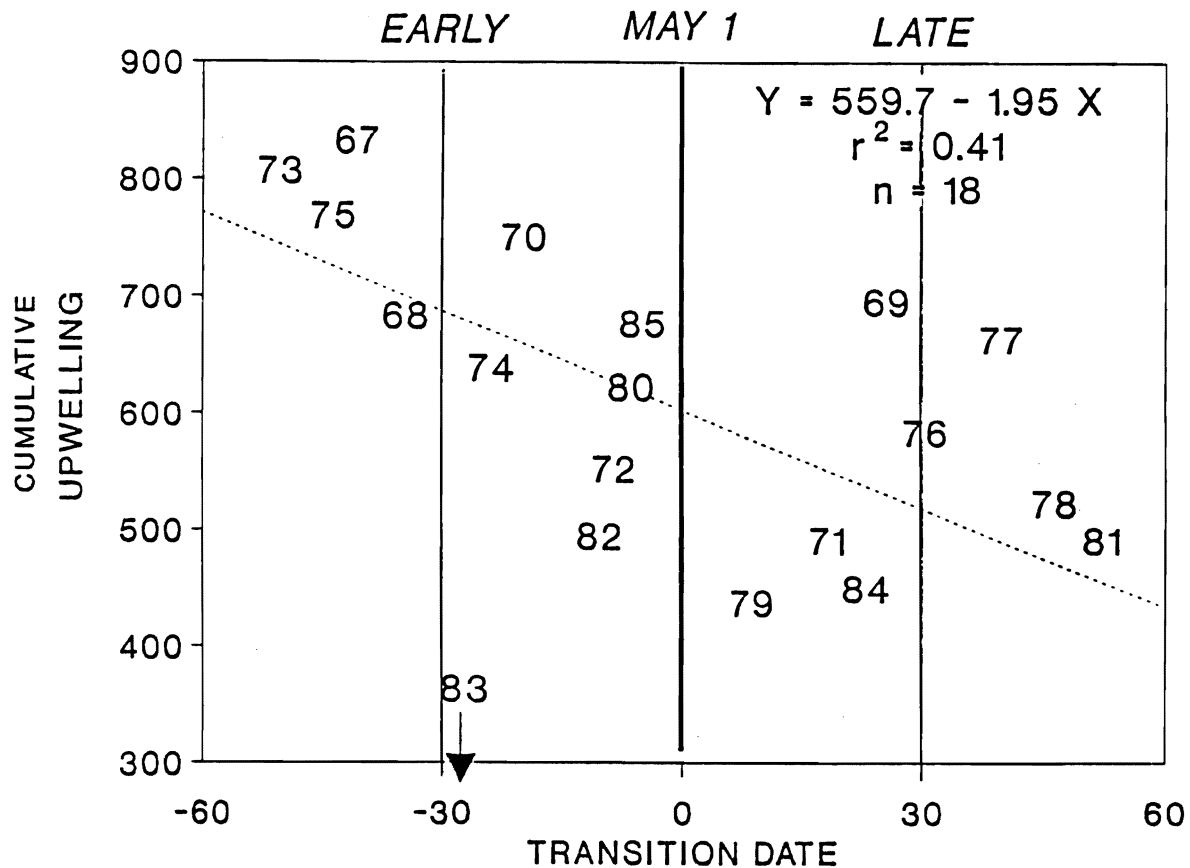

Figure 4. Relationship between relative transition date (May 1 = 0) and cumulative daily upwelling strength (cubic meters per second per 100 m of coastline) from March through September at 42°N 125°W. Upwelling data through 1981 are from Nickelson (1986), and the remaining years were calculated from data in Mason and Bakun (1986). The regression equation is fit to all years with the exception of 1983 (-28, 177) which was considered an anomalous year.

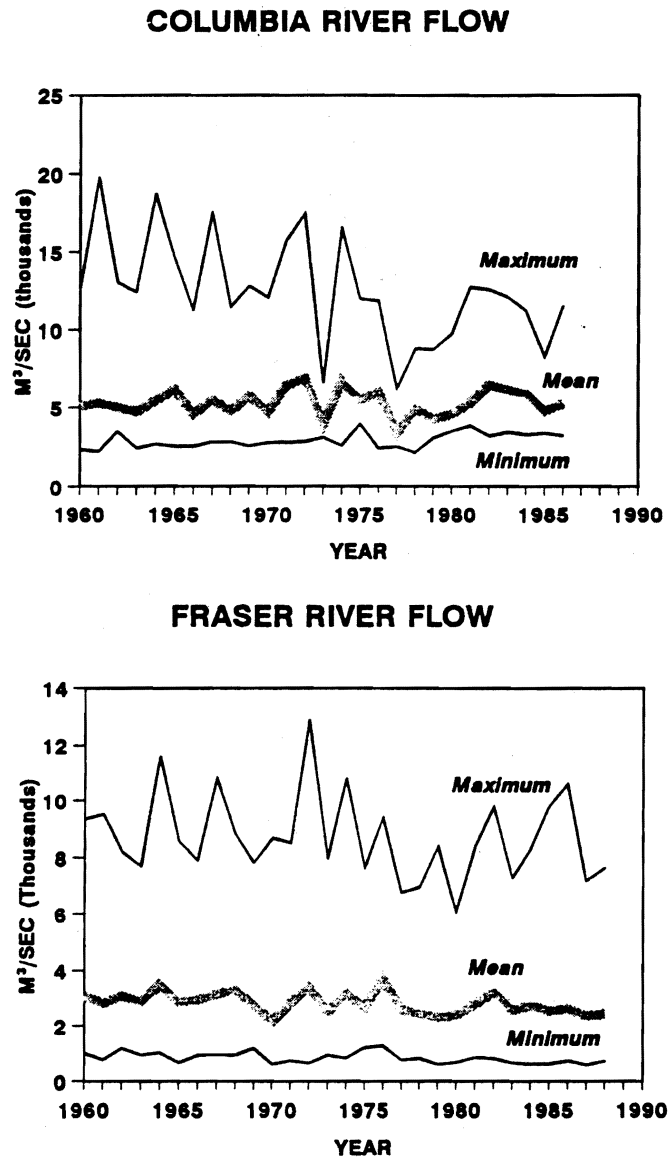

Figure 5. Comparison of monthly means (heavy lines) and the minimum and maximum monthly values (thin lines) for the Columbia River and the Fraser River (from Francis et al. (1989) and P. LeBlond, University of British Columbia, unpubl. data).

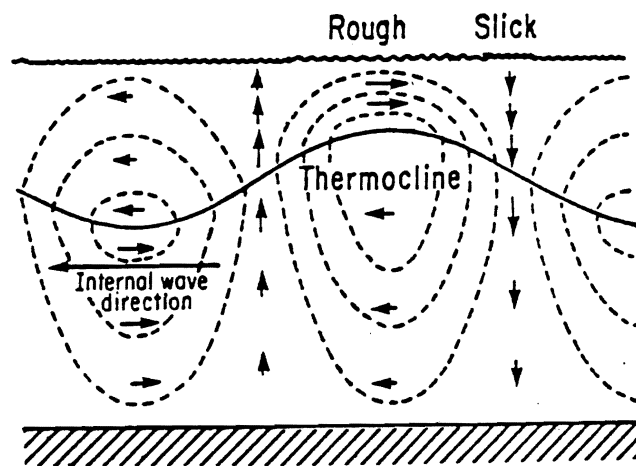
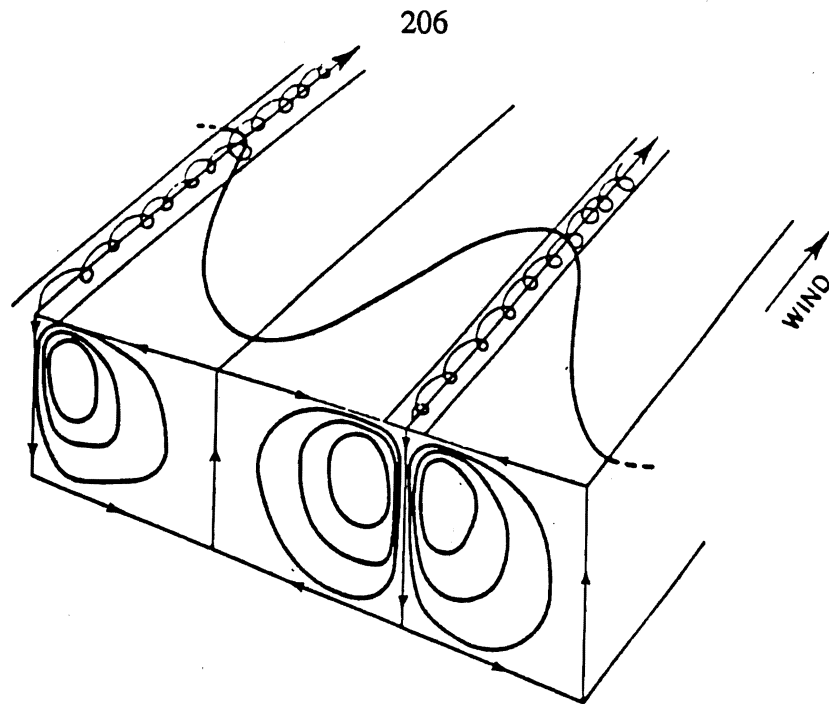

Figure 6. Convergence zones in surface waters created by Langmuir circulation (upper) and internal waves (lower). Upper figure is from Barstow (1983) and lower figure is from Shanks and Wright (1987).

discussed here, other processes such as long-term environmental trends and regime shifts (McLain 1984, Francis and Hare 1994, Brodeur et al. 1996), upwelling intensity (Nickelson 1986), and coastal currents (Pearcy and Fisher 1988) may also be important. Upwelling intensity appears to be the most important factor controlling food production in the coastal zone for juvenile salmon. Both the duration of upwelling events as well as the absolute intensity over the entire upwelling season may be important (Cury and Roy 1989). Excessive or persistent upwelling-favorable winds may be detrimental to coastal primary production in that nutrient-rich waters will be continuously advected offshore (Small and Menzies 1981).

Clearly, comprehensive reviews of oceanographic factors affecting juvenile salmon, such as those by Tabata (1984) for sockeye salmon (*O. nerka*) off British Columbia and Pearcy (1992) for coho salmon off Oregon and Washington, should be desirable reading for any biologist intending to do research on ocean salmon survival. We can no longer afford to ignore the variability inherent in the marine system when studying the variability in ocean survival. Salmon biologists would be wise to interact with physical oceanographers or at least become cognizant of many physical processes likely to affect the ecology of salmon in the ocean.

Citations

- Barnes, C. A., A. C. Duxbury, and B. A. Morse. 1972. Circulation and selected properties of the Columbia River effluent at sea. In A. T. Pruter and D. L. Alverson (editors), The Columbia River estuary and adjacent ocean waters, p. 41-80. Univ. Washington Press, Seattle.
- Barstow, S. F. 1983. The ecology of Langmuir circulation: A review. *Mar. Environ. Res.* 9:211-236.
- Beamish, R. J. (editor). 1995. Climate change and northern fish populations. *Can. Spec. Pub. Fish. Aquat. Sci.* 121:1-739.
- Brodeur, R. D. 1989. Neustonic feeding by juvenile salmonids in coastal waters of the Northeast Pacific. *Can. J. Zool.* 67:1995-2007.
- Brodeur, R. D. 1992. Factors related to variability in feeding intensity of juvenile coho and chinook salmon. *Trans. Am. Fish. Soc.* 121:104-114.
- Brodeur, R. D., R. C. Francis, and W. G. Pearcy. 1992. Food consumption of juvenile coho (*Oncorhynchus kisutch*) and chinook salmon (*O. tshawytscha*) on the continental shelf off Washington and Oregon. *Can. J. Fish. Aquat. Sci.* 49:1670-1685.

- Brodeur, R. D., B. W. Frost, S. R. Hare, R. C. Francis, and W. J. Ingraham, Jr. 1996. Interannual variations in zooplankton biomass in the Gulf of Alaska and covariation with California Current zooplankton biomass. *Calif. Coop. Oceanic Fish. Invest. Rep.* 37:80-99.
- Brodeur, R. D., and W. G. Pearcy. 1990. Trophic relations of juvenile Pacific salmon off the Oregon and Washington coast. *Fish. Bull., U.S.* 88:617-636.
- Brodeur, R. D., and W. G. Pearcy. 1992. Effects of environmental variability on trophic interactions and food web structure in a pelagic upwelling ecosystem. *Mar. Ecol. Prog. Ser.* 84:101-118.
- Cury, P., and C. Roy. 1989. Optimal environmental window and pelagic fish recruitment success in upwelling areas. *Can. J. Fish. Aquat. Sci.* 46:670-680.
- Denman, K. L., and T. M. Powell. 1984. Effects of physical processes on planktonic ecosystems in the coastal ocean. *Ocean. Mar. Biol. Ann. Rev.* 22:125-168.
- Dickey, T. D. 1990. Physical-optical-biological scales relevant to recruitment in large marine ecosystems. *In* K. Sherman, L. M. Alexander, and B. D. Gold (editors), *Large marine ecosystems: Patterns, processes, and yields*, p. 82-98. *Am. Assoc. Adv. Sci. Publ.* 90-305.
- Fiedler, P. C. 1984. Satellite observations of the 1982-1983 El Niño along the U.S. Pacific Coast. *Science* 224:1251-1254.
- Fiedler, P. C., and R. M. Laurs. 1990. Variability of the Columbia River plume observed in visible and infrared satellite imagery. *Int. J. Remote Sens.* 11:999-1010.
- Fiedler, P. C., G. B. Smith, and R. M. Laurs. 1984. Fisheries applications of satellite data in the eastern North Pacific. *Mar. Fish. Rev.* 46:1-13.
- Fisher, J. P., and W. G. Pearcy. 1988. Growth of juvenile coho salmon (*Oncorhynchus kisutch*) in the ocean off Oregon and Washington, USA, in years of differing coastal upwelling. *Can. J. Fish. Aquat. Sci.* 45:1036-1044.
- Francis, R. C., and S. R. Hare. 1994. Decadal-scale regime shifts in the large marine ecosystems of the North-east Pacific: A case for historical science. *Fish. Oceanogr.* 3:279-291.
- Francis, R. C., W. G. Pearcy, R. D. Brodeur, J. P. Fisher, and L. Stevens. 1989. Effects of the ocean environment on the survival of juvenile salmonids. *Univ. Washington, Fish. Res. Inst. Rep.*, Seattle, 34 p.

- Fulton, J. D., and R. J. LeBrasseur. 1985. Interannual shifting of the subarctic boundary and some of the biotic effects on juvenile salmonids. *In* W. S. Wooster and D. L. Fluharty (editors), *El Niño North: Niño effects in the eastern subarctic Pacific*, p. 237-247. Washington Sea Grant Program, Univ. Washington, Seattle. Publ. WSG-WO-85-3.
- Haury, L. R., and R. E. Pieper. 1987. Zooplankton: scales of biological and physical events. *In* D. F. Soule and G. S. Kleppel (editors), *Marine organisms as indicators*, p. 35-72. Springer Verlag, New York.
- Healey, M. C. 1982. Timing and relative intensity of size-selected mortality of juvenile chum salmon (*Oncorhynchus keta*) during early sea life. *Can. J. Fish. Aquat. Sci.* 39:952-957.
- Huyer, A., and R. L. Smith. 1985. The signature of El Niño off Oregon, 1982-1983. *J. Geophys. Res.* 90:7133-7142.
- Johnson, S. L. 1988. The effects of the 1983 El Niño on Oregon's coho (*Oncorhynchus kisutch*) and chinook (*O. tshawytscha*) salmon. *Fish. Res.* 6:105-123.
- Kingsford, M. J., and J. H. Choat. 1986. Influence of surface slicks on the distribution and onshore movements of small fish. *Mar. Biol.* 91:161-171.
- Legendre, L., and S. Demers. 1984. Towards dynamic biological oceanography and limnology. *Can. J. Fish. Aquat. Sci.* 41:2-19.
- Mann, K. H., and J. R. N. Lazier. 1991. *Dynamics of marine ecosystems*. Blackwell Scientific Publications, Cambridge, MA, 467 p.
- Mason, J. E., and A. Bakun. 1986. Upwelling index update, U.S. West Coast, 33°N-48°N latitude. U.S. Dep. Commer., NOAA Tech. Memo. NMFS-SWFC 67; 81 p.
- McLain, D. R. 1984. Coastal ocean warming in the Northeast Pacific, 1976-83. *In* W. G. Percy (editor), *The influence of ocean conditions on the production of salmonids in the North Pacific*, p. 61-86. Oregon Sea Grant Program, Oregon State Univ., Corvallis. Publ. ORESU-W-83-001.
- Mysak, L. A. 1986. El Niño, interannual variability and fisheries in the Northeast Pacific Ocean. *Can. J. Fish. Aquat. Sci.* 43:464-497.
- Nickelson, T. E. 1986. Influences of upwelling, ocean temperature, and smolt abundance on marine survival of coho salmon (*Oncorhynchus kisutch*) in the Oregon production area. *Can. J. Fish. Aquat. Sci.* 43:527-535.

- Owen, R. W. 1981. Fronts and eddies in the sea: mechanisms, interactions and biological effects. *In* A. R. Longhurst (editor), *Analysis of marine ecosystems*, p. 197-233. Academic Press, New York.
- Pearcy, W. G. 1988. Factors affecting survival of coho salmon off Oregon and Washington. *In* W. J. McNeil (editor), *Salmon production, management, and allocation*, p. 67-73. Oregon State Univ. Press, Corvallis.
- Pearcy, W. G. 1992. *Ocean ecology of North Pacific salmonids*. Univ. Washington Press, Seattle, 179 p.
- Pearcy, W. G., and J. P. Fisher. 1988. Migrations of coho salmon, *Oncorhynchus kisutch*, during their first summer in the ocean. *Fish. Bull.*, U.S. 86:173-195.
- Pearcy, W., J. Fisher, R. Brodeur, and S. Johnson. 1985. Effects of the 1983 El Niño on coastal nekton off Oregon and Washington. *In* W. S. Wooster and D. L. Fluharty (editor), *El Niño North: Niño effects in the eastern subarctic Pacific*, p. 188-204. Washington Sea Grant Program, Univ. Washington, Seattle. Publ. WSG-WO-85-3.
- Pearcy, W. G., and D. F. Keene. 1974. Remote sensing of water color and sea surface temperatures off the Oregon coast. *Limnol. Ocean.* 19:573-583.
- Pearcy, W. G., and A. Schoener. 1987. Changes in the marine biota coincident with the 1982-1983 El Niño in the northeastern subarctic Pacific Ocean. *J. Geophysical Res.* 92:14417-14428.
- Scarnecchia, D. L. 1981. Effects of streamflow and upwelling on yield of wild coho salmon (*Oncorhynchus kisutch*) in Oregon. *Can. J. Fish. Aquat. Sci.* 38:471-475.
- Shanks, A. L., and W. G. Wright. 1987. Internal-wave-mediated shoreward transport of cyprids, megalopae, and gammarids and correlated longshore differences in the settling rate of intertidal barnacles. *J. Exp. Mar. Biol. Ecol.* 114:1-13.
- Shenker, J. M. 1988. Oceanographic associations of neustonic larval and juvenile fishes and Dungeness crab megalopae off Oregon, 1984. *Fish. Bull.*, U.S. 86:299-317.
- Small, L. F., and D. W. Menzies. 1981. Patterns of primary productivity and biomass in a coastal upwelling region. *Deep-Sea Res.* 28:123-149.
- Steele, J. (editor). 1978. *Spatial pattern in plankton communities*. Plenum Press, New York, 470 p.
- St. John, M. A., J. S. Macdonald, P. J. Harrison, R. J. Beamish, and E. Choromanski. 1992. The Fraser River plume: some preliminary observations on the distribution of juvenile salmon, herring, and their prey. *Fish. Ocean.* 1:153-162.

- Tabata, S. 1984. Oceanographic factors influencing the distribution, migration, and survival of salmonids in the Northeast Pacific Ocean--A review. *In* W. G. Pearcy (editor), The influence of ocean conditions on the production of salmonids in the North Pacific, p. 128-160. Oregon Sea Grant Program, Oregon State Univ., Corvallis. Publ. ORESU-W-83-001.
- Zirges, M. H. 1981. A hypothesis for coho salmon survival mechanisms. Coho Salmon Management Plan. Oregon Dep. Fish and Wildlife, Newport.



CLIMATE-OCEAN CHANGES AND THE IMPACTS ON YOUNG SALMON IN THE STRAIT OF GEORGIA

R. J. Beamish and C. Neville

Fisheries and Oceans Canada
Pacific Biological Station
Nanaimo, BC Canada V9R 5K6

The climate event that occurred in the winter of 1976-77 resulted in changes in the ocean that altered the productivity trends of a number of commercially important fishes. The effects were particularly noticeable in salmon stocks. The productivity of pink (*Oncorhynchus gorbuscha*), chum (*O. keta*), and sockeye (*O. nerka*) salmon stocks that reared in the subarctic Pacific increased, while the productivity of coho (*O. kisutch*) and chinook (*O. tshawytscha*) salmon stocks in the Strait of Georgia and probably off the coasts of Washington and Oregon decreased. The synchrony of the changes and the use of hatchery reared smolts to maintain the total production of smolts leaves little doubt that the marine changes were largely responsible for the declines in productivity of these coastal stocks.

Catches of chinook salmon in the Strait of Georgia began to decline in 1979 (Fig. 1). Synchronous with this decline was an abrupt and precipitous decrease in marine survival from an average of 4.8% from 1974 to 1977 (year to sea) to 0.7% from 1978 to 1988 (year to sea). If overfishing was the major cause of the decline, there would be a gradual reduction in smolt production at the time of the decrease in catch and marine survival. However, the total number of wild and hatchery reared chinook salmon smolts produced after the declines actually increased from a yearly average of about 30×10^6 from 1974-76 to about 82×10^6 in the early 1990s (Beamish et al. 1995).

There was a decline in coho salmon survival shortly after the decrease occurred for chinook salmon (Fig. 2). Although the average catch of coho salmon in the Strait of Georgia remained about the same, there was an increase in smolt production from about 15×10^6 before the change in survival to about 25×10^6 smolts in the early 1990s. Because the marine mortality for hatchery reared and wild coho salmon is about equal, it is clear that the addition of smolts to the Strait of Georgia did not increase the total abundance of post-juvenile fish over the pre-1977 levels.

The changes that occurred in the abundance and survival of chinook and coho salmon in the Strait of Georgia were coincident with several key physical changes that in turn were coincident with other major climate-ocean changes that occurred in the winter of 1976-77. The common factor affecting both of these ecosystems was the Aleutian low pressure system. The intensification of the low in the late 1970s increased production of salmon species resident in the offshore areas, possibly through increases in mid-ocean upwelling. The linkages with the ecosystem in the Strait of Georgia are not well understood, but they

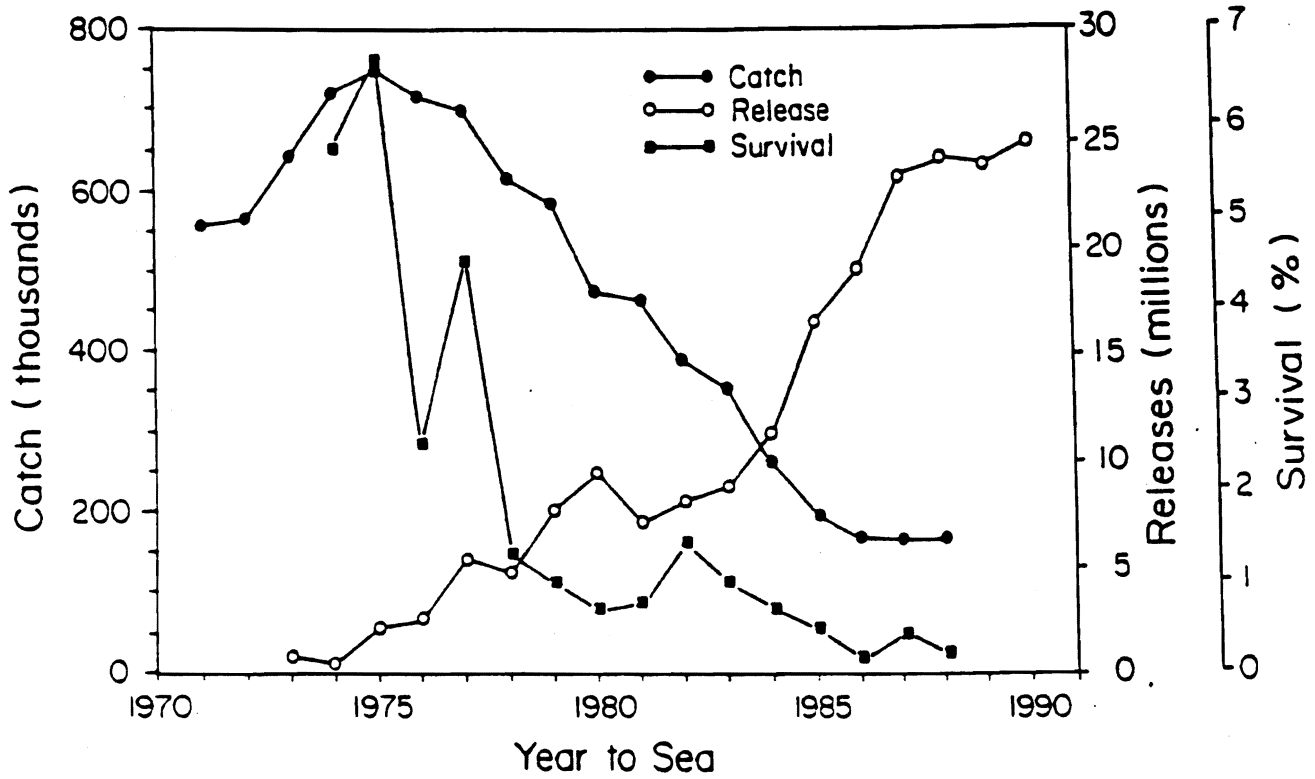

Figure 1. Commercial and sport catch of chinook salmon in the Strait of Georgia showing a declining catch beginning in 1976. The decline in hatchery survival occurred at about the same time. The releases from Strait of Georgia increased as the catches declined.

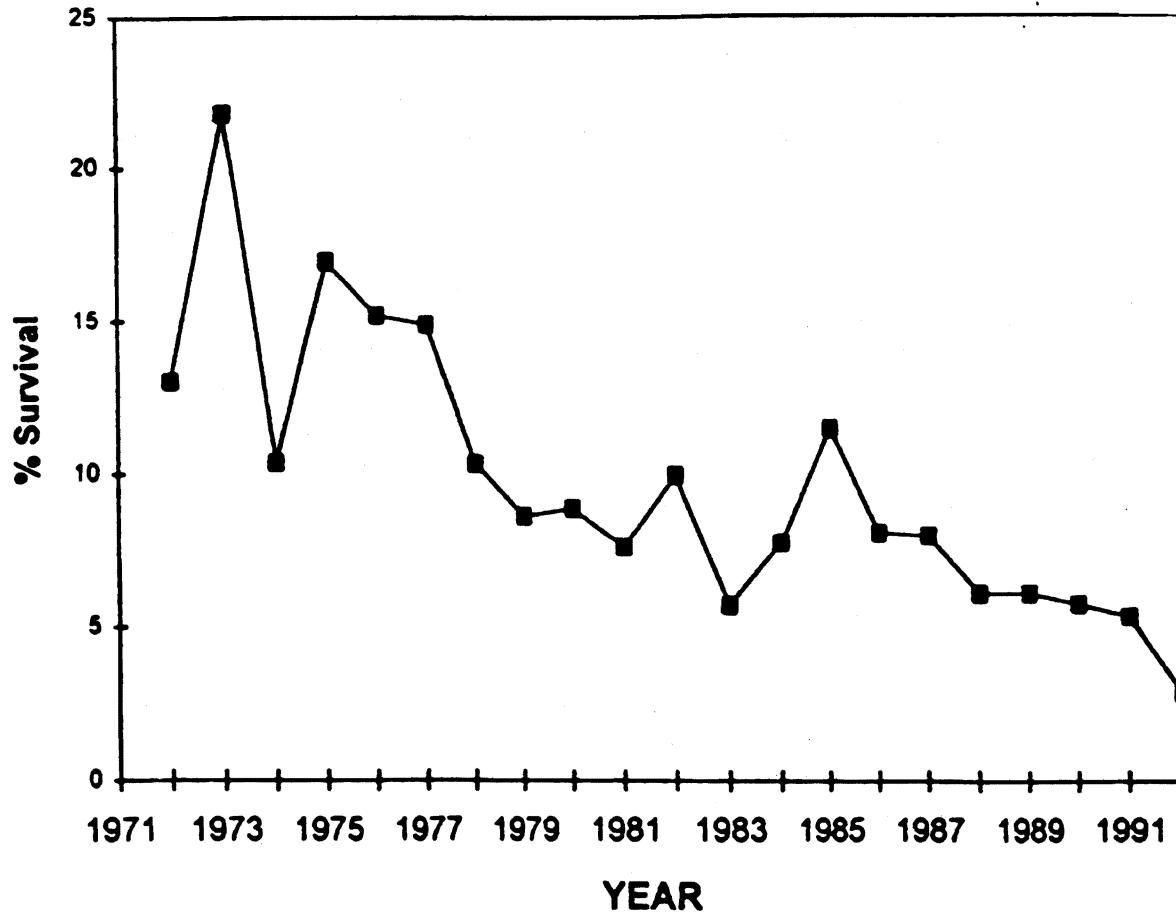

Figure 2. Survival of coho salmon from the Strait of Georgia and Fraser River hatcheries. There was a decline in average survival about 1978, approximately the same time as for chinook salmon.

involved decreases in the snowpack and subsequently in the annual flows of the Fraser River. At the same time that the trend in flows started to decline, there was an increase in the bottom and surface temperatures in the strait. The reasons for the increases in temperatures are unknown as are the relationships with the production of coho and chinook salmon; however, it is clear that the changes would affect the Strait of Georgia ecosystem. It is also clear that the message for fisheries management is that it is necessary to understand both the natural and human factors affecting coho and chinook salmon abundance.

Beginning about 1989, there was another change in the climate-ocean system. In the tropical Pacific, the change appeared as a persistent and strong negative anomaly of the Southern Oscillation Index that was associated with higher sea surface temperatures (Trenberth and Hoar 1996). In the subarctic Pacific, sea surface temperature anomalies indicated that some warming in the central subarctic Pacific had occurred (Deser et al. 1996) and there were changes in the trend of the Aleutian low pressure system and other large-scale climate indices (Beamish et al. in prep.).

In the Strait of Georgia, there was continued warming of the surface and bottom layers. There also were larger discharges in April from the Fraser River than occurred in the past (Fig. 3). These larger spring discharges are important because they affect the timing of the spring plankton bloom. Associated with the change in the pattern of the April flows was a trend for coho salmon from the Strait of Georgia to move out of the strait (Fig. 4) and rear off the west coast of Vancouver Island. This is noteworthy because coho salmon fishing in the Strait of Georgia supports one of the most important recreational fisheries in Canada. For example, in past years at the same time of this meeting, there would be a rather substantial fishery for juvenile coho salmon. Our recent studies for this year indicate that there are virtually no coho salmon in the strait.

We suspect that the ecosystem in the Strait of Georgia changed again when the physical indices changed about 1989-90. We observed increases in the survival and abundance of Pacific hake (*Merluccius productus*) as well as observing that large numbers of chum salmon remained in the strait longer than they did in the past. There also is an indication that Pacific herring (*Clupea pallasii*) are in high abundance. In association with our colleagues, we are carrying out a 3-year study of the physical and biological factors that cause these regime shifts.

Regimes are a new and important concept in the management of Pacific salmon. A productivity regime can be considered to be the level of production within a particular ecosystem. While it is this level of production that is important for fish stocks, it is the change in regimes that is an important reference point for managers. It has been assumed in the past that the survival of salmon in the ocean is either without a long-term trend or that the highest, historic levels of production represent the upper limits of the possible marine production. The concept of regime shifts in which the equilibrium level of production abruptly increases or decreases has, in general, not been considered to be an important part of Pacific salmon management.

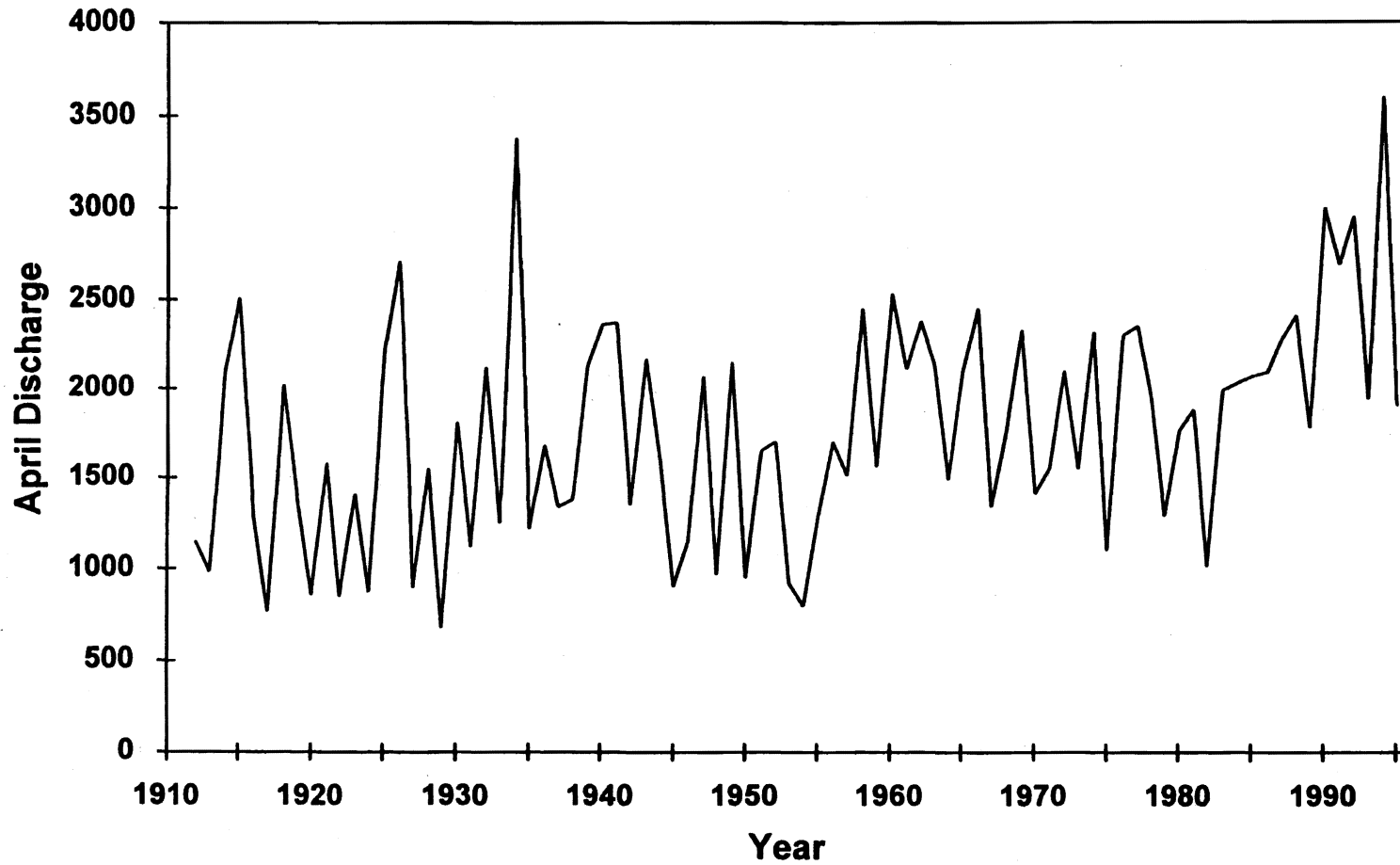

Figure 3. Average daily discharge of the Fraser River at Hope for April from 1910 to 1995. Note that since 1990, April discharge has on average been the highest in the time series.

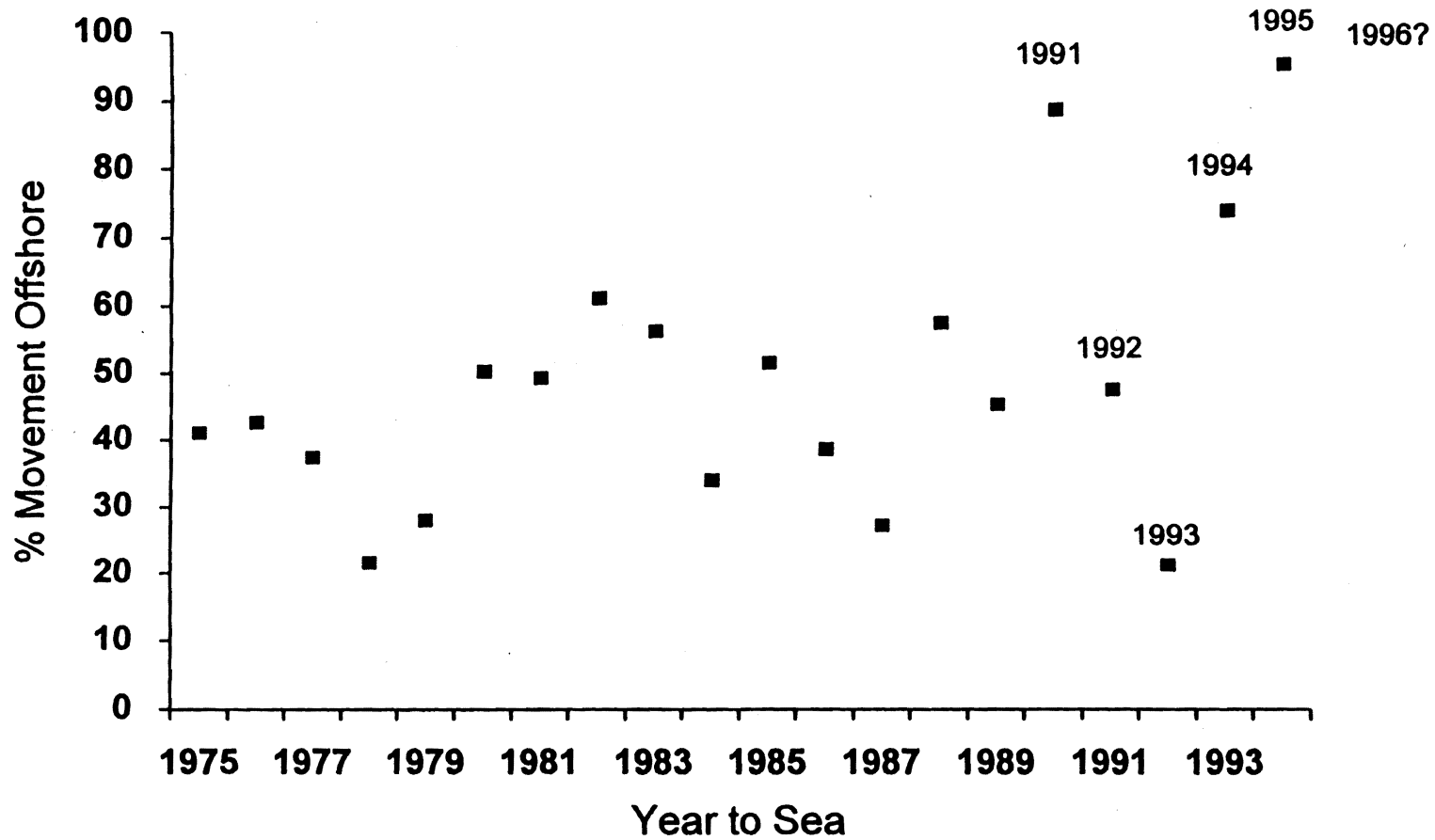

Figure 4. Percent of coho salmon caught in waters outside the Strait of Georgia that were released from hatcheries in the Strait of Georgia and Fraser River. Years written on figure are catch years. Note that since 1991 the majority of the coho salmon are moving out of the strait. The value for 1996 is an estimate but is not expected to be lower than indicated.

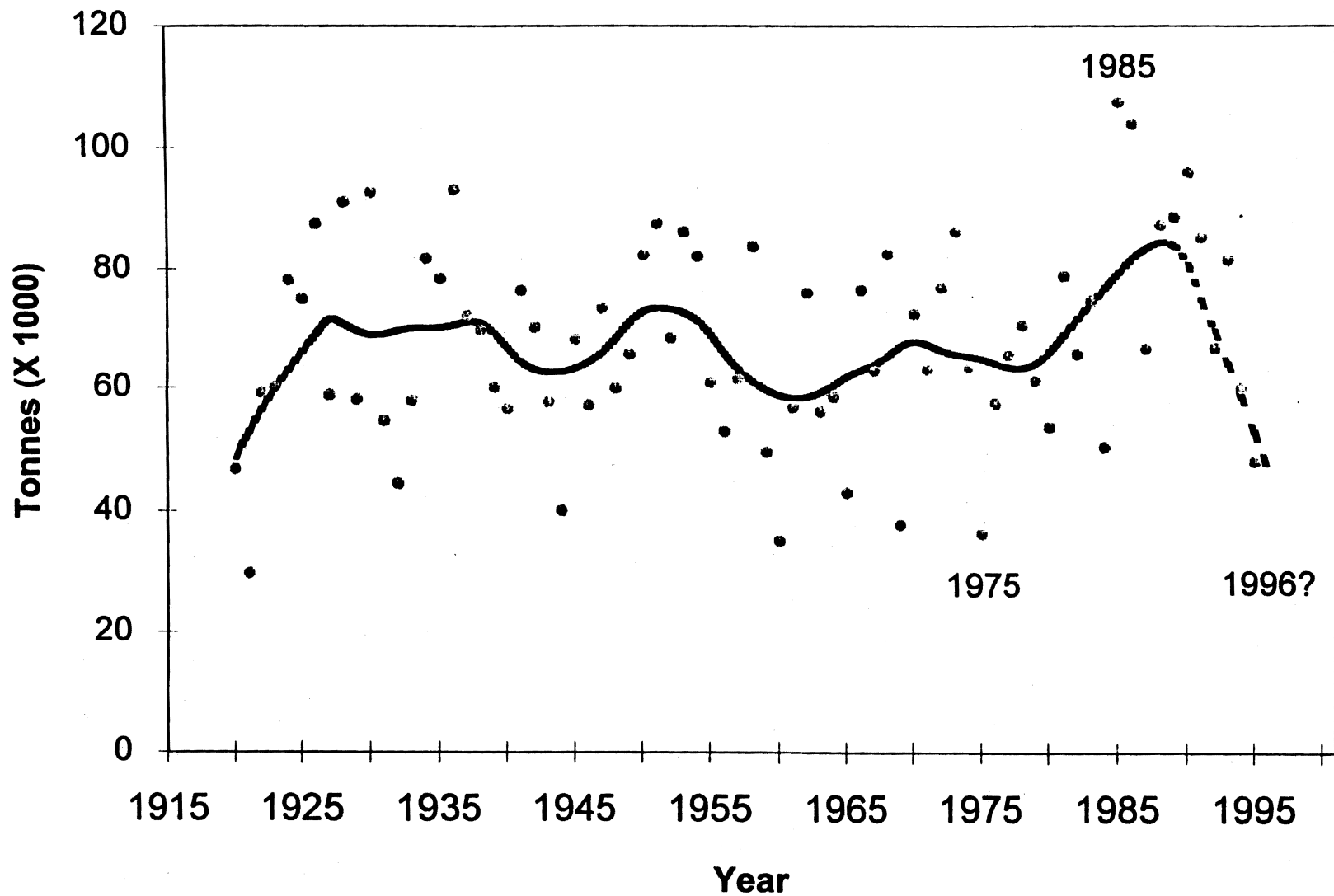

Figure 5. Catch of Pacific salmon in British Columbia from 1920 to 1995. The decline in recent years probably is related to ocean conditions. The 1996 catch should be one of the lowest in the time series in part because of the ocean conditions and in part because of the cyclic nature of pink and sockeye salmon. 1997 catches are expected to be higher, which will mean that the decline shown in the figure will not be as great.

For fish populations, a regime shift is a change in production that is coincident with climate-ocean changes that result in a response that is synchronous for a number of species (or stocks), usually over a relatively large area. According to this definition, it is an abrupt change in equilibrium production that is important and not a reversal in a fluctuating trend.

The changes in both 1976-77 and 1989-90, although different, would be regime shifts according to our definition. In general, the 1976-77 shift included a temperature reversal and a change (increase) in the intensity of the Aleutian low. The 1989-90 change appeared as a change to higher temperatures in some areas as well as a change (decrease) in the intensity of the Aleutian low pressure system.

It is now 20 years after the 1976-77 event occurred and there is still no explanation of the cause of the event. There is growing acceptance of the impact on fishes and increasing evidence linking the climate trends in the tropical Pacific to the changes observed in the ocean, but there is no explanation of the mechanisms involved. Although the events cannot be controlled as we attempt to do for fishing effects, the effects of the regime shifts have profound impacts on regional economies. For example, it is clear when one looks at the history of the total catches of all Pacific salmon in British Columbia (Fig. 5) that the recent low catches and resulting economic hardships are in some way associated with climate effects. There are also associated impacts on the effectiveness of government expenditures and programs and on the credibility of fisheries studies. The most serious impact, however, may be in relation to our ability to detect and adapt to the effects on our fisheries caused by a general warming of our climate.

Citations

- Beamish, R. J., G. A. McFarlane, and D. Noakes. In prep. Evidence that decadal scale changes in global processes are linked to natural shifts in production of Pacific salmon. (Available from Canadian Department of Fisheries and Oceans, Pacific Biological Station, Nanaimo, B.C., Canada V9R 5K6.)
- Beamish, R. J., B. E. Riddell, C. M. Neville, B. L. Thomson, and Z. Zhang. 1995. Declines in chinook salmon catches in the Strait of Georgia in relation to shifts in the marine environment. *Fish. Ocean.* 4(3):243-256.
- Deser, C., M. Alexander, and M. Timlin. 1996. Upper-ocean thermal variations in the North Pacific during 1970-91. *J. Climate* 9:1840-1855.
- Trenberth, K. E., and T. J. Hoar. 1996. The 1990-1995 El Niño-Southern Oscillation event: Longest on record. *Geophys. Res. Letters.* 23(1):57-60.

EARLY OCEAN SURVIVAL OF SALMON OFF BRITISH COLUMBIA
AND IMPACTS OF THE 1983 AND 1991-95 EL NIÑO EVENTS

Brent N. Hargreaves
Canadian Department of Fisheries and Oceans
Biological Sciences Branch
Pacific Biological Station
Nanaimo, BC Canada V9R 5K6

Chinook salmon (*Oncorhynchus tshawytscha*) from the west coast of Vancouver Island (WCVI) have become a major contributor to commercial troll and recreational fisheries in British Columbia and southeast Alaska. The Somass River/Robertson Creek chinook stock is the most important WCVI stock, with total production exceeding 400,000 adults as recently as 1991. However, marine survival rates of this stock have varied by over two orders of magnitude.

Chinook salmon produced by this stock in a given year can return as 2-, 3-, 4-, 5-, or 6-year-old adults. Although only a small percentage return as 2-year-old males (jacks), once returns from these younger fish are known, the total return for that brood year for all years can be reliably forecast. This indicates that marine survival patterns are predominantly determined during the first year of marine life, before the first jacks return.

Variations in ocean conditions appear to strongly affect marine survival of WCVI chinook salmon stocks. The lowest marine survival rates observed previously for the Somass stock (0.1% for the 1983 brood year) coincided with the 1983 El Niño event. This effect was relatively modest, however, since only one brood year was affected. More recent El Niño events in 1991-95 have affected survival for at least three consecutive brood years (1990 to 1992), and this has had a much greater impact. The returns of WCVI chinook salmon in 1995 were low, and returns in 1996 and 1997 are forecast to be extremely poor. Predation on juvenile chinook salmon during the early marine period was likely a major cause of the poor survivals of the 1983 and 1991-93 brood years. The cause of the longer term pattern of declining survival rates which preceded both of these major El Niño events is not known.



Process and Mechanisms--Offshore Marine



OFFSHORE DISTRIBUTION AND MIGRATION PATTERNS AND OCEAN SURVIVAL OF SALMON

Katherine W. Myers

Fisheries Research Institute
University of Washington
Box 357980, Seattle, WA 98195-7980

Almost all data (1955-92) on offshore distribution and migration patterns of northeastern Pacific salmon (*Oncorhynchus* spp.) were obtained by the national research programs of the member nations of the former International North Pacific Fisheries Commission (INPFC). The results of much of the research through the early 1970s are summarized by species in five joint-comprehensive reports issued by INPFC on coho (*O. kisutch*; Godfrey et al. 1975), sockeye (*O. nerka*; French et al. 1976), chum (*O. keta*; Neave et al. 1976), chinook (*O. tshawytscha*; Major et al. 1978), and pink (*O. gorbuscha*; Takagi et al. 1981) salmon. More recently, reports were issued on offshore distribution and migration patterns of steelhead (*O. mykiss*; Burgner et al. 1992), and on the distribution and origins of salmon and steelhead in the area of the former Japanese land-based driftnet salmon fishery, south of lat. 46°N (Myers et al. 1993). The final Bulletin in the INPFC series included information on distribution of salmon and steelhead in the area of the former squid driftnet fisheries (e.g., Pella et al. 1993).

The primary objective of the historical U.S. and Canadian offshore research was to determine if the Japanese high seas driftnet fisheries were catching North American salmon. Before 1978, field research was concentrated in the times (primarily May-July) and areas of the Japanese mothership salmon driftnet fisheries, particularly in the vicinity of the INPFC abstention line along meridian 175°W, which was the eastern boundary of Japanese salmon fishing. With the implementation of U.S.S.R. and U.S. 200-mile zones in 1977-78, the times, areas, and fishing quotas of the Japanese fisheries were reduced. In 1978, the eastern boundary of the fishery was moved to long. 175°E, and research emphasis shifted to identifying the continent of origin of salmonids caught by the expanding Japanese land-based driftnet fishery in the offshore area south of 46°N. In the late 1980s and early 1990s, as the times, areas, and catch quotas of the salmon driftnet fisheries were further reduced, research emphasis shifted again to determining the bycatch of salmonids by the rapidly developing Asian squid driftnet fisheries in the area south of 46°N and west of 140°W.

The historical data are not adequate to provide a good understanding of the offshore distribution and migration patterns of northeastern Pacific salmonids. Most of the research in the Gulf of Alaska, which is the major offshore rearing area for many northeastern Pacific salmon populations, was done opportunistically during the 1950s and 1960s, primarily in spring and summer (April-August). Data from offshore areas south of the Gulf of Alaska (south of 50°N) and off the U.S. West Coast are particularly limited. Spatial and temporal

distribution of sampling effort and the types of gear used to catch salmon varied. Almost all salmon catches were by surface gear (gillnet, longlines, and purse seines), and they do not provide information on vertical distribution of salmon. Sea surface temperature was often the only oceanographic data collected. There have been significant changes in abundance and composition of northeastern Pacific salmon populations since the mid-1960s (e.g., Rogers 1986). In addition, there have been major changes in North Pacific climate and oceanography since the mid-1960s (summarized by Trenberth and Hurrell 1995).

The historical data have been used to develop conceptual models of seasonal offshore distribution and migration patterns of northeastern Pacific salmon by combining observations from all gear types and years (e.g., Neave et al. 1976, French et al. 1976, Takagi et al. 1981). The models do not provide information on discrete populations or on interannual variation in distribution and migration patterns, and they need to be validated with new field data.

High seas tag recovery data (1955-95) provide limited evidence that offshore distribution and migration patterns of Pacific salmon are population-specific. The most extensive data are for sockeye salmon, which were the major focus of the historical U.S. and Canadian research programs. These data clearly show that Asian and North American sockeye have different ocean ranges (Fig. 1A). North American populations from large lake or river systems also have broadly overlapping but different ocean ranges (e.g., Bristol Bay and Fraser River, Fig. 1A). Analyses of the tag data with respect to expected returns indicated that Bristol Bay fish with different early life histories have different ocean distribution and migration patterns (Rogers 1986; Fig. 1B). The high seas tag data are not adequate to determine offshore distributions of discrete populations of northeastern Pacific salmon because the majority of recoveries were made in coastal, mixed-stock fisheries.

Many scientists have concluded from the historical data that offshore movements of Pacific salmon are not random and involve sophisticated orientation or true navigation (e.g., Quinn 1991). Tagging and tracking studies show that movements of individual adult Pacific salmon returning from offshore to coastal waters are rapid and direct (e.g., Ogura and Ishida 1995). Tagging and transplantation experiments on Atlantic salmon (*Salmo salar*) indicate that offshore patterns of migration and orientation of salmonids at sea are stock-specific traits (Kallio-Nyberg and Ikonen 1992, Hansen et al. 1993). Direction of homeward migration from offshore waters involves an inherited crude compass sense of direction (Hansen et al. 1993). Kallio-Nyberg and Ikonen (1992) hypothesized that stock-specific ocean feeding migration patterns result from natural selection of fish having the shortest possible route to sufficiently good feeding areas for growth and reproduction, and that intra-stock variation in these patterns is related to biological and environmental factors. Magnetite crystals in the brain tissues of salmon may provide an internal compass needle that aligns with the earth's magnetic field (e.g., Mann et al. 1988) or, as in pied flycatchers (*Ficedula hypoleuca*), geomagnetically controlled melatonin may transmit genetically encoded orientational data (Schneider et al. 1994). As in loggerhead sea turtles (*Caretta caretta*; Light et al. 1993), salmon may use inherited geomagnetic compass directions and angles of

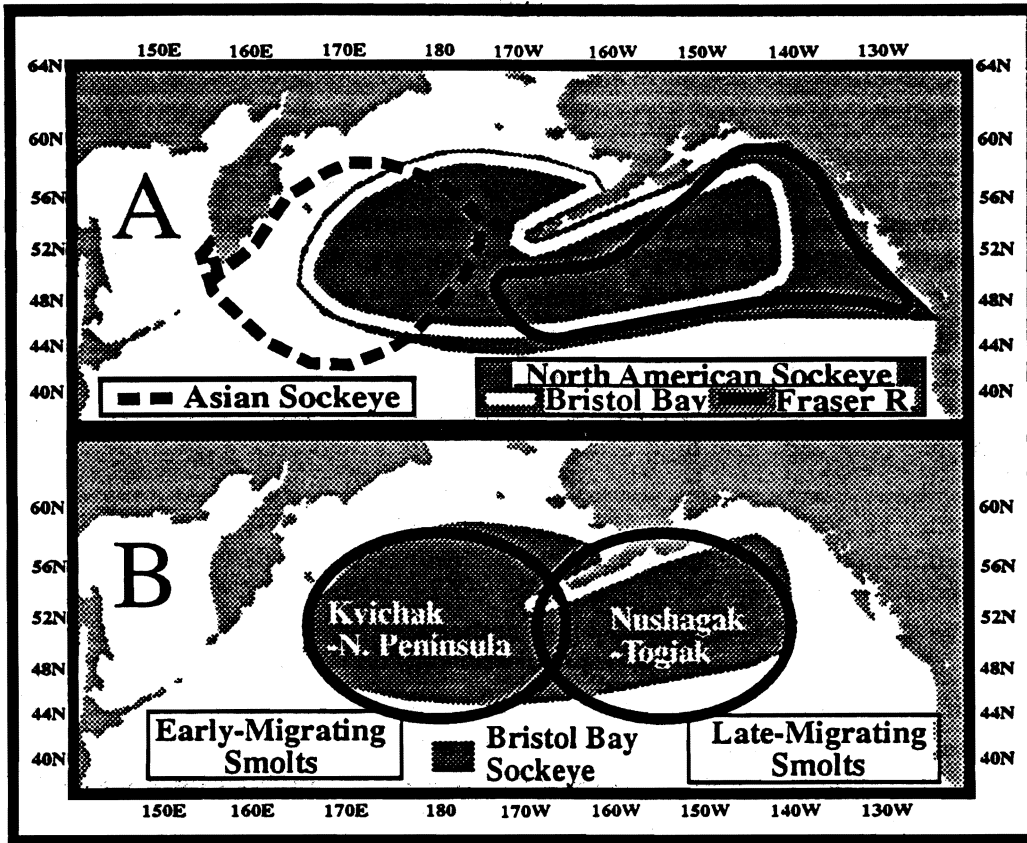

Figure 1. Known ocean ranges of sockeye salmon from coastal recoveries of high seas tagged fish (1954-95). A. Asian and North American sockeye. B. Bristol Bay sockeye, adapted from information in Rogers (1986).

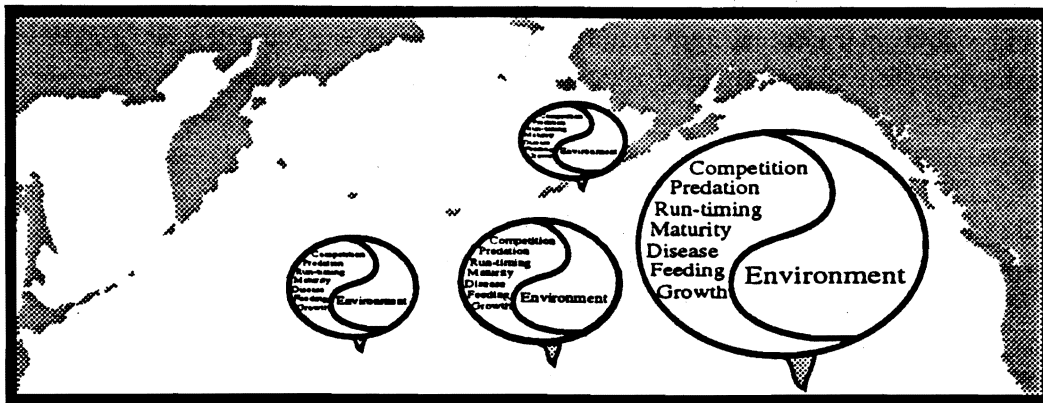

Figure 2. A conceptual model of the relationship between offshore distribution and migration patterns and natural mortality (see text for explanation).

inclination and anomalies of the earth's magnetic field to navigate during their extensive offshore migrations.

Few population-specific estimates of offshore mortality rates have been published. Offshore mortality rates of maturing pink salmon, calculated directly from abundance estimates of fish from the Karaginskii region of eastern Kamchatka, Russia, show considerable annual variation (55.4-95.8%, brood years 1986-91), and in some years are higher than coastal mortality rates of juveniles (Karpenko 1995).

In the past, the Japanese high seas salmon driftnet fisheries were a major cause of offshore mortality. Differences in offshore distribution and migration patterns made some populations more vulnerable to high seas fishing mortality than others. For example, tag return data indicate that the ocean distribution of eastern Kamchatka sockeye salmon directly overlapped the area of the pre-1978 mothership salmon driftnet fishery. Konovalov (1985) estimated an exploitation rate of 90% by the mothership fishery on spring sockeye salmon from Lake Azabayachi. In 1977, the U.S.S.R. 200-mile zone was closed to fishing, and after 1977 no fishing was allowed in the area north of 46°N in May, when the traditional fishery targeted sockeye salmon. After these closures, populations of Lake Azabayachi spring sockeye recovered rapidly (estimated abundance of spawning adults increased by 25 times from 1977 to 1984; Konovalov 1985).

The last year of operation of the high seas salmon driftnet fisheries was 1991, and the last year of operation of the high seas squid driftnet fisheries, which had a bycatch of salmon, was 1992. The Convention for Conservation of Anadromous Stocks in the North Pacific Ocean (CCAS, signed by Canada, Japan, Russia, and the United States in 1992) prohibits all directed fishing for salmon in international waters of the North Pacific Ocean and Bering Sea. In addition, United Nations (UN) Resolution 46/215, passed in December 1991, called for a worldwide moratorium on all high seas large-scale driftnet fishing. Prior to the CCAS and UN moratorium, substantial "unauthorized" salmon driftnet fishing operations were being conducted on the high seas in violation of international treaties on salmon fishing (Pella et al. 1993). The new international agreements, combined with the current low market value of salmon, have effectively eliminated illegal offshore fishing for salmon.

Predation by other dominant epipelagic species (e.g., killer whales (*Orcinus orca*), northern fur seals (*Callorhinus ursinus*), and salmon sharks (*Lamna ditropis*)) is likely an important cause of natural mortality of salmon during offshore feeding and adult return migrations. Other factors such as disease, parasites, starvation, and unusual environmental events (e.g., El Niño) may also play a major role, but the direct causes of natural mortality in offshore waters remain largely unknown.

Environmental changes that adversely affect complex biological processes (e.g., feeding, growth, maturation, run-timing, competition, predation, and disease) are likely the major mechanisms underlying natural mortality in offshore waters. Figure 2 is a conceptual

model of natural mortality in offshore waters. The ellipses represent the distribution of a discrete population at various critical life history stages. The Chinese yin-yang symbol within the ellipses represents the dynamic interaction between environment and biological processes. Within an area of distribution, changing environmental conditions affect various complex biological processes, which in turn may change environmental conditions. Through this iterative process, distributions of discrete populations expand, contract, or shift, and offshore survival increases or decreases.

Phases in offshore distribution and migration patterns critical to survival are 1) juvenile emigration, 2) summer feeding, 3) overwintering, and 4) adult migration. In conceptual models of migration patterns developed from historical data, offshore movement and distribution of northeastern Pacific juvenile salmon is inferred from the distribution of immature age 0.1 fish in the following spring. Early juvenile migrants may have moved well offshore by January, whereas late migrants may remain for the entire winter in protected inshore or coastal areas, and move directly offshore in the spring. Interannual variation in timing of juvenile outmigrations and environmental conditions and, subsequently, the distribution of juvenile salmon populations at the end of their first winter or beginning of the first spring at sea may play a critical role in migration patterns and run-timing of returning adults (Rogers 1986). Most offshore growth in salmon occurs during summer months. Summer movements from one offshore feeding area to another through coastal waters may result in increased predation or fishing mortality. Competition in offshore feeding areas may result in decreased growth and increased age at maturity, and mortality may increase because fish must remain at sea longer before maturing. Salmon are probably most susceptible to predation, starvation, and disease in winter, and some populations may move from offshore into coastal areas, where increased rates of marine mammal predation and fishing mortality may occur. Interannual variation in timing and offshore location of adult movements may affect location of entry into coastal areas, and, subsequently, interception in coastal fisheries and timing of runs to river mouths (Blackbourn 1987). New offshore research should focus on obtaining population-specific information on offshore distribution and migration patterns and associated biological processes and environmental conditions during critical life history phases.

Citations

- Blackbourn, D. J. 1987. Sea surface temperature and pre-season prediction of return timing in Fraser River sockeye salmon (*Oncorhynchus nerka*). Can. Spec. Publ. Fish. Aquat. Sci. 96:296-306.
- Burgner, R. L., J. T. Light, L. Margolis, T. Okazaki, A. Tautz, and S. Ito. 1992. Distribution and origins of steelhead trout (*Oncorhynchus mykiss*) in offshore waters of the north Pacific Ocean. Int. North Pac. Fish. Comm. Bull. 51:1-92.

- French, R., H. Bilton, M. Osako, and A. Hartt. 1976. Distribution and origin of sockeye salmon (*Oncorhynchus nerka*) in offshore waters of the North Pacific Ocean. Int. North Pac. Fish. Comm. Bull. 34:1-113.
- Godfrey, H., K. A. Henry, and S. Machidori. 1975. Distribution and abundance of coho salmon in offshore waters of the North Pacific Ocean. Int. North Pac. Fish. Comm. Bull. 31:1-80.
- Hansen, L. P., N. Jonsson, and B. Jonsson. 1993. Oceanic migration in homing Atlantic salmon. Anim. Behav. 45:927-941.
- Kallio-Nyberg, I., and E. Ikonen. 1992. Migration pattern of two salmon stocks in the Baltic Sea. ICES J. Mar. Sci. 49:191-198.
- Karpenko, V. I. 1995. Estimates of ocean mortality of northeast Kamchatka pink salmon. North Pac. Anad. Fish. Comm. Doc. 168:1-6. (Available from Kamchatka Research Institute of Fisheries and Oceanography, 18 Naberezhnaya, Petropavlovsk-Kamchatskii, Russia 683602.)
- Konovalov, S. M. 1985. Scientific principles of the rational exploitation of Pacific salmon and its basic scheme. Soviet J. Mar. Biol. 11(3):119-128.
- Light, P., M. Salmon, and K. J. Lohmann. 1993. Geomagnetic orientation of loggerhead sea turtles: Evidence for an inclination compass. J. Exp. Biol. 182:1-9.
- Major, R. L., J. Ito, S. Ito, and H. Godfrey. 1978. Distribution and abundance of chinook salmon (*Oncorhynchus tshawytscha*) in offshore waters of the North Pacific Ocean. Int. North Pac. Fish. Comm. Bull. 38:1-54.
- Mann, S., N. H. G. Sparks, M. M. Walker, and J. L. Kirschvink. 1988. Ultrastructure, morphology and organization of biogenic magnetite from sockeye salmon, *Oncorhynchus nerka*: Implications for magnetoreception. J. Exp. Biol. 140:35-49.
- Myers, K. W., C. K. Harris, Y. Ishida, L. Margolis, and M. Ogura. 1993. Review of the Japanese landbased driftnet salmon fishery in the western North Pacific Ocean and the continent of origin of salmonids in this area. Int. North Pac. Fish. Comm. Bull. 52:1-86.
- Neave, F., T. Yonemori, and R. G. Bakkala. 1976. Distribution and origin of chum salmon in offshore waters of the North Pacific Ocean. Int. North Pac. Fish. Comm. Bull. 35:1-79.

- Ogura, M., and Y. Ishida. 1995. Homing behavior and vertical movements of four species of Pacific salmon (*Oncorhynchus* spp.) in the central Bering Sea. *Can. J. Fish. Aquat. Sci.* 52:532-540.
- Pella, J., R. Rumbaugh, L. Simon, M. Dahlberg, S. Pennoyer, and M. Rose. 1993. Incidental and illegal catches of salmonids in North Pacific driftnet fisheries. *Int. North Pac. Fish. Comm. Bull.* 53(III):325-358.
- Quinn, T. P. 1991. Models of Pacific salmon orientation and navigation on the open ocean. *J. Theor. Biol.* 150:539-545.
- Rogers, D. E. 1986. Pacific salmon. *In* D.W. Hood and S. T. Zimmerman (editors), *The Gulf of Alaska, physical environment and biological resources*, p. 461-476. NOAA, Ocean Assessments Division, Alaska Office. (Available from the Nat. Tech. Info. Serv., U.S. Dep. Commerce, Springfield, VA 22161.)
- Schneider, T., P. Thalau-Hans, P. Semm, and W. Wiltschko. 1994. Melatonin is crucial for the migratory orientation of pied flycatchers (*Ficedula hypoleuca pallas*). *J. Exp. Biol.* 194:255-262.
- Takagi, K., K. V. Aro, A. C. Hartt, and M. B. Dell. 1981. Distribution and origin of pink salmon (*O. gorbuscha*) in offshore waters of the North Pacific Ocean. *Int. North Pac. Fish. Comm. Bull.* 40:1-195.
- Trenberth, K. E., and J. W. Hurrell. 1995. Decadal coupled atmosphere-ocean variations in the North Pacific Ocean. *In* R. J. Beamish (editor), *Climate change and northern fish populations*, p. 15-24. *Can. Spec. Publ. Fish. Aquat. Sci.* 121.

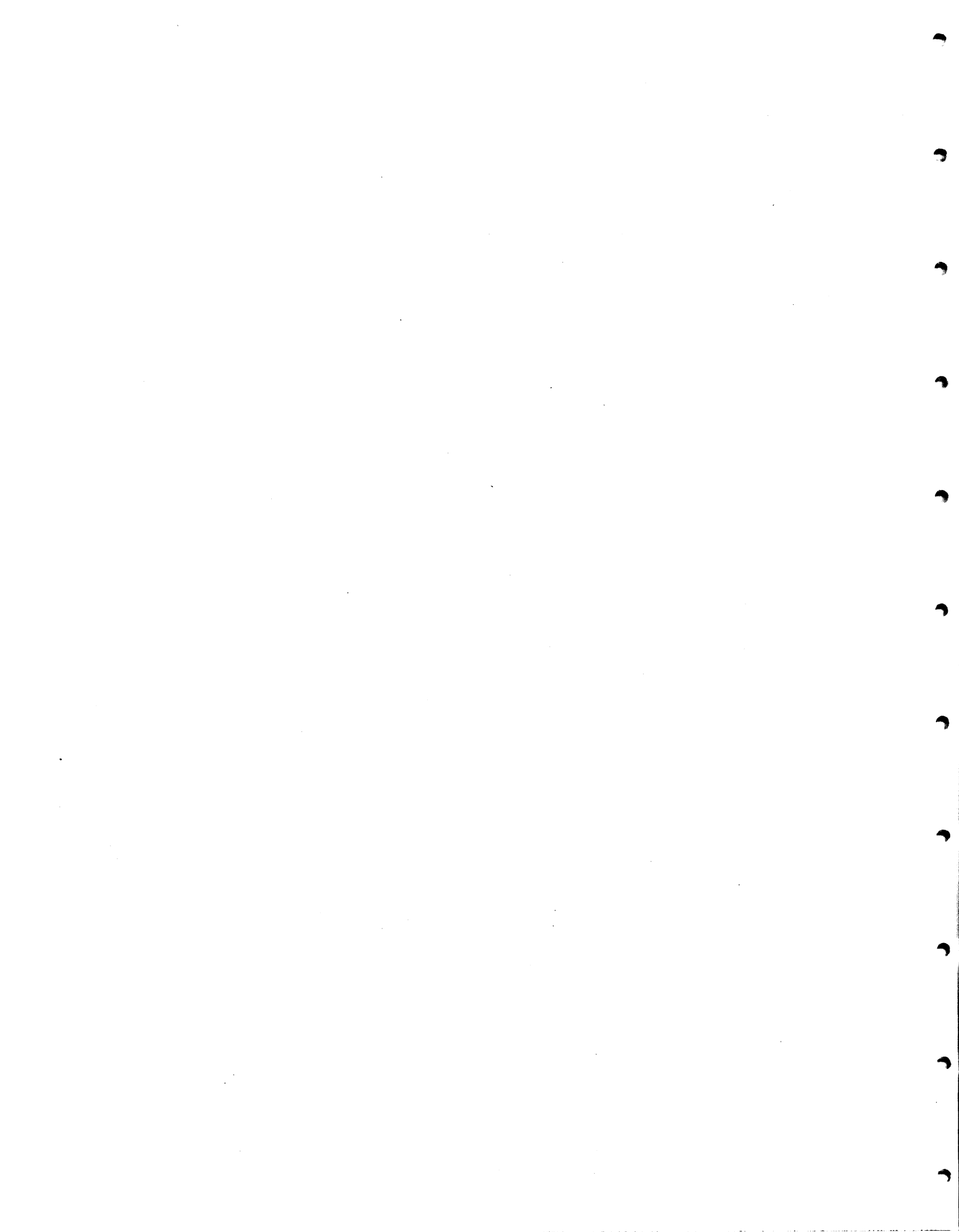

MODELING TEMPORAL AND SPATIAL PATTERNS
OF SALMON MIGRATION, FEEDING, AND GROWTH
IN THE NORTHEAST PACIFIC OCEAN

Peter S. Rand, James P. Scandol, and Scott G. Hinch

Fisheries Centre and Westwater Research Unit
University of British Columbia
Vancouver, BC Canada V6T 1Z4

Processes of migration, growth, and survival of Pacific salmon in off-shore marine environments are poorly understood. Because of logistical difficulties in sampling and experimentation on the high seas, very few directed field efforts have been conducted to try to gain insight into biological mechanisms regulating growth and survival of salmon in this environment. Many of the measures of final ocean weight of salmon stocks from British Columbia suggest a long-term reduction in mean size, perhaps related to climate change (Hinch et al. 1996, Cox and Hinch in review). Many questions of critical importance both to basic science, as well as to developing better practical management policies, need to be addressed to gain a more comprehensive understanding of growth and survival of these and other important stocks during their high seas life history stage.

We contend that much can be gained through reanalysis of past data bases involving extensive biological sampling, coupled with the application of state-of-the-art approaches in statistics, modeling, and data visualization that can offer fresh insights into spatial and temporal patterns in the data. In this paper we describe a series of data bases that have been developed over the past 40+ years and some preliminary results from analyses. We also describe the development of an interactive software shell that allows users to test hypotheses concerning migration and growth processes of salmon on the high seas. We apply the results of the data analyses and modeling exercises to test the following hypotheses: 1) British Columbia sockeye salmon (*Oncorhynchus nerka*) complete two loops around the Alaskan Gyre as a result of simple behavioral rules of compass orientation and swim speed and estimated off-shore current fields, 2) meso- (100-300 km) and gyre-scale (>1000 km) patterns exist in zooplankton biomass and salmon feeding and growth that arise from physical oceanographic processes, 3) the sharply defined southern limits of salmon biomass is a result of a reduction in growth-rate potential across latitude, and 4) during spring of 1962, the area of highest growth rate potential for salmon can be found in the center of the gyre, resulting from an optimal mix of prey abundance and thermal properties.

Data Sources and Analytical Methods

We compiled data on sea surface temperatures (SST, COADS database), off-shore current fields (Thomson et al. 1994), zooplankton biomass (LeBrasseur 1965a, Brodeur and

Ware 1992), and salmon diets (LeBrasseur 1965b). The latter two data sets were based on archived data records from the Pacific Biological Station at Nanaimo, British Columbia. The period of biological sampling occurred during 1956-64. The sampling was extensive in space (lat. 40-60°N, long. 120-160°W) and time (1957-64, all seasons). We focused data analysis on the biological measures of prey (zooplankton) and predator (salmon) and tested for significant spatial patterns and responses along latitudinal environmental gradients. We expressed the diet data in terms of a measure of stomach fullness (proportion of maximum daily ration), which accounts for body size-allometric effects on feeding rates (Hewett and Kraft 1993). We applied Mantel's tests (Mantel 1967) to detect spatial dependence in the zooplankton and salmon gut fullness data, and developed correlograms using distance class intervals to gain insight into the nature of the spatial patch structure. We also explored the relationship between SST and latitude and these biological measures.

Patterns in Zooplankton Prey and Salmon Stomach Fullness

We found evidence of spatial patterns (i.e., data were spatially autocorrelated) in a majority of the zooplankton biomass data sets. There appear to be two consistent scales at which spatial dependence is evident. We detected meso- (100-300 km) and gyre-scale (>1000 km) spatial dependence (Fig. 1). These results are consistent with the hypothesis that meso-scale physical structure (e.g., eddies) may lead to the formation of meso-scale food "patches," while dominant offshore current fields within the Gulf of Alaska may provide a physical template for the distribution of zooplankton at much larger scales of observation.

Analyses of pink (*O. gorbuscha*) and sockeye salmon stomach fullness during spring and summer of 1962 indicated spatial similarities at a scale of approximately 1,200 km (Fig. 1). The presence of coherence in the data at this scale suggests that predators are responding to the general gyre-scale patterns detected in the prey "landscape." We also found a four- to five-fold reduction in stomach fullness measures between approximately 9°C and 10°C SST for sockeye salmon and between 10°C and 12°C SST for pink salmon. We also discovered a sharp reduction in stomach contents below lat. 50°N, which was coincident with a reduction in zooplankton biomass. We used the results of these analyses to develop temperature- and prey-dependent foraging functions that were applied in the models described below.

Modeling Methods and Results

The model tracks individual migration and growth trajectories of salmon beginning on 15 August in the vicinity of the Queen Charlotte Islands and is terminated 660 days later (15 June) at predicted endpoints on the high seas. The model is individual-based (IBM) and operates on a 5-day time step at a spatial resolution of 1° lat. by 1° long. The structure of the migration submodel has been described elsewhere (Walter et al. in review). Algorithms to estimate swim speed and bioenergetic losses can be found in a number of publications (e.g., Beauchamp et al. 1989). The model predicts ration and growth based on occupied

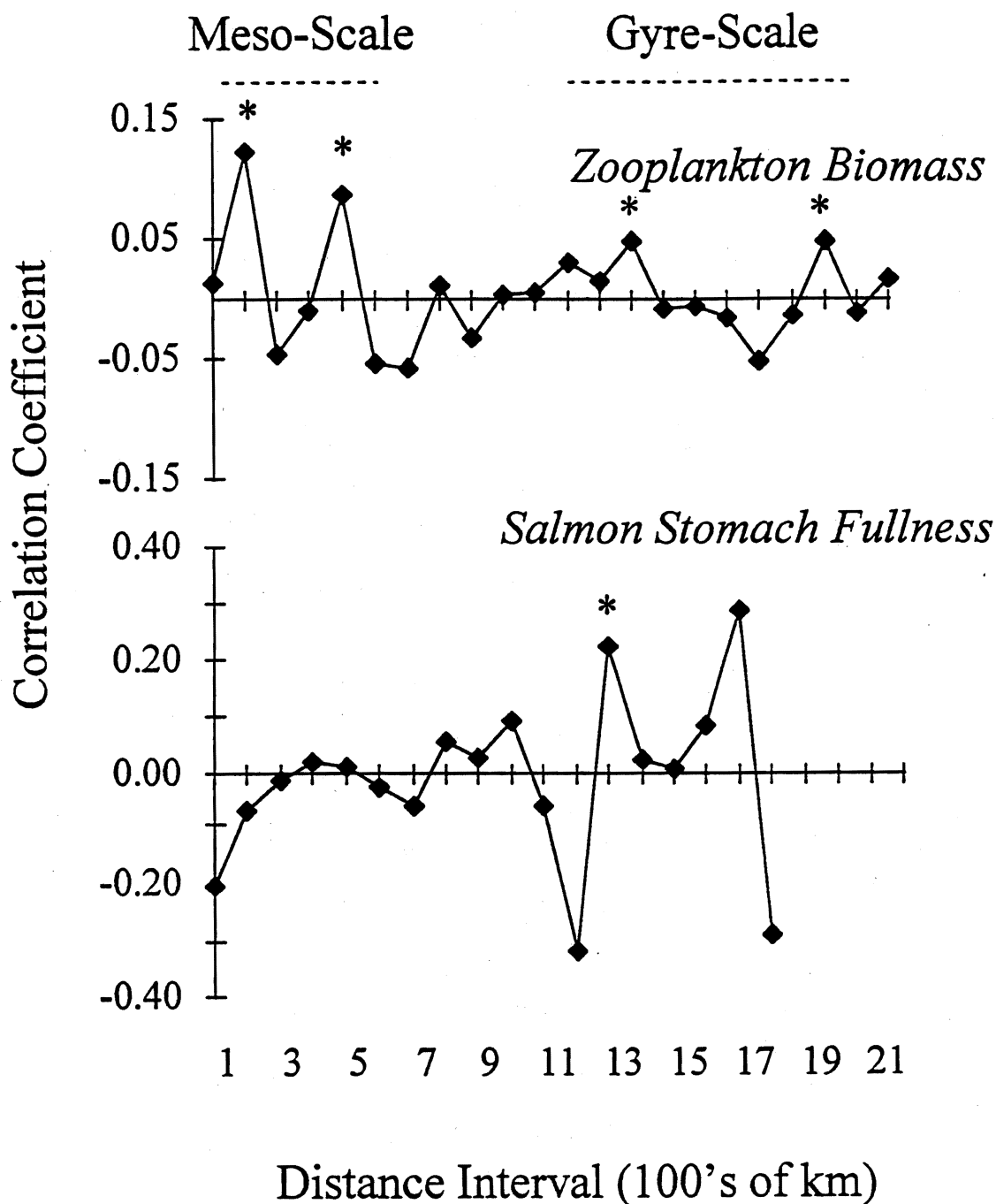

Figure 1. Correlograms describing meso- (100-300 km) and gyre- (>1000 km) scale dependent patch structures in zooplankton biomass and pink salmon stomach fullness during May-June 1962 in the Northeast Pacific Ocean. High positive correlation coefficients (* = significance at $P = 0.05$) indicate coherence in response variables at sampling stations separated at a given distance interval. Note coherence in gyre scale patterns between prey biomass and predator feeding.

temperature and prey biomass within each cell in the spatial matrix (Fig. 2). We express growth rates in two different ways. The first is the observed mean and range of projected weights across all individuals in an IBM simulation. The second is the growth rate potential (e.g., Brandt et al. 1992) for a representative 500-g sockeye salmon within each cell in the ocean matrix given the spatial variability in SST and zooplankton biomass, which provides a visual "snapshot" of growth conditions across the Northeast Pacific Ocean.

We tracked the migration trajectory, feeding, bioenergetics, and growth of 200 individual sockeye salmon over 660 days in the coast and high seas environments of the Northeast Pacific Ocean. The model results suggest that salmon are more likely to complete only one loop around the Gulf of Alaska prior to their spawning migration (Fig. 3). In order for individuals in the model to complete two loops around the gyre, it was necessary to invoke directed swimming behaviors that moved salmon in a direction parallel to the dominant gyre currents. We report here the results of the IBM using the former, simpler migration model. In the IBM simulation, variability in occupied temperatures was relatively low, while variability in encounters with prey was highly variable (Fig. 4), resulting from the prey patch structure defined above. Growth rate in the model appeared to conform to a seasonal cycle, with highest rates of growth observed during the spring and summer, and lowest growth rates during fall and winter.

We computed spatially explicit growth-rate potential for a 500-g sockeye salmon in the Northeast Pacific Ocean during four seasons. Growth-rate potential was clearly highest and most spatially heterogeneous during the spring (Fig. 5). The greatest potential for growth during this season appeared to be centered in the mid- to lower-region of the Alaskan Gyre. This central region appeared to correspond to an optimal mix of sufficient levels of prey abundance and preferable thermal properties. A very sharp reduction in growth rate potential is evident in the southern latitudes, where growth rate declines from a high of nearly 2% body weight per day to -0.5% body weight per day along a transect of approximately 300 km. This feature arises from the interaction between levels of zooplankton biomass (and related feeding rates) and temperature-dependent metabolic demands. This may provide a plausible hypothesis to explain the sharp "thermal" limits in the oceanic distribution of salmon as described by Welch et al. (1995). One can also discern an area in the center of the gyre that supports relatively high growth-rate potential for salmon, surrounded by concentric "rings" of lower potential (Fig. 5). These general patterns in growth-rate potential emerge from the results described above identifying the importance of prey abundance and temperature on salmon feeding.

Discussion

The present model represents the product of collaborative efforts by physical, biological, and fisheries oceanographers, along with expertise in computer software design and data visualization. This effort represents a rare, successful marriage between biology and technology, and will allow new insights into the ecology of Pacific salmon in coastal and high

Spatial Model Framework

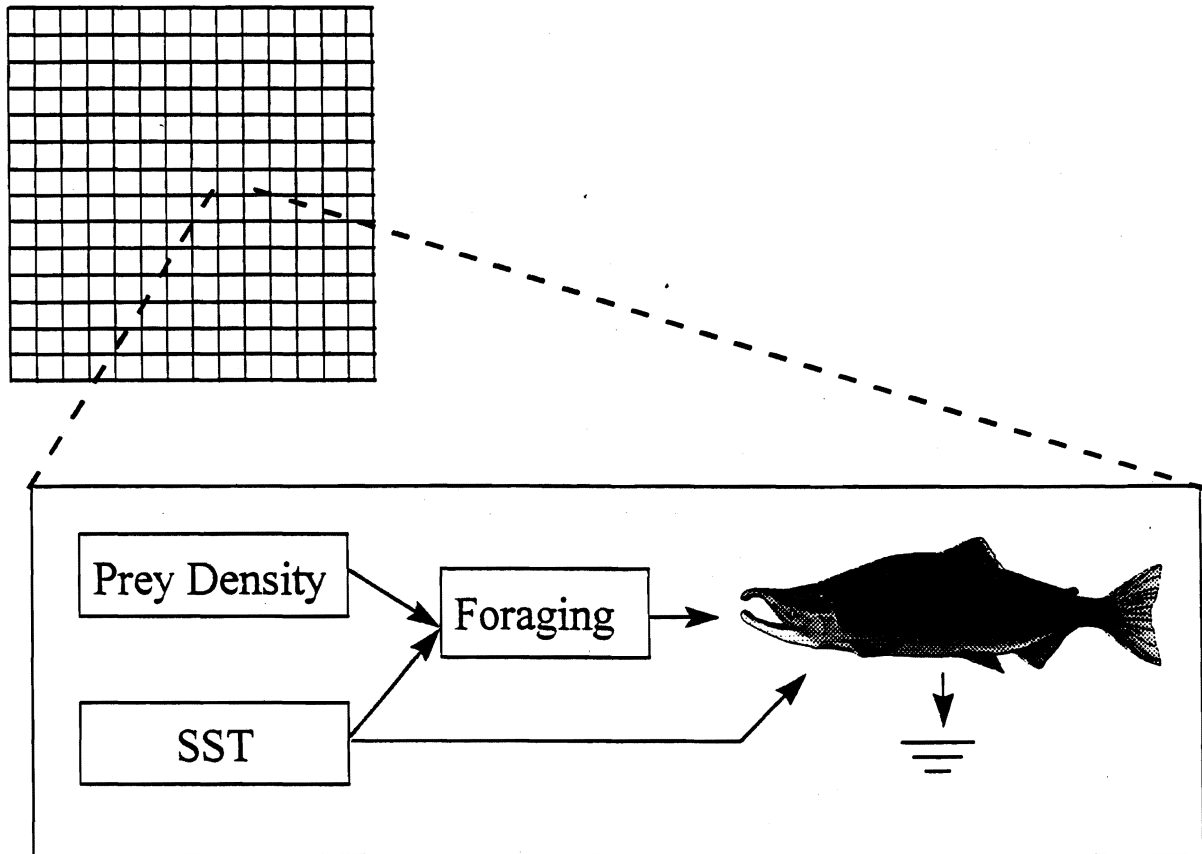

Figure 2. Diagram representing approach to modeling spatially explicit, individual-based responses of salmon to prey and temperature in the North Pacific Ocean. The spatial (1° lat. by 1° long.) and temporal (5 day) resolution of the model was chosen to achieve a balance between capturing relatively fine-scale biological processes while minimizing computational burden. Prey and temperature were integrated through foraging and bioenergetic algorithms to estimate growth potential for each cell in the ocean matrix.

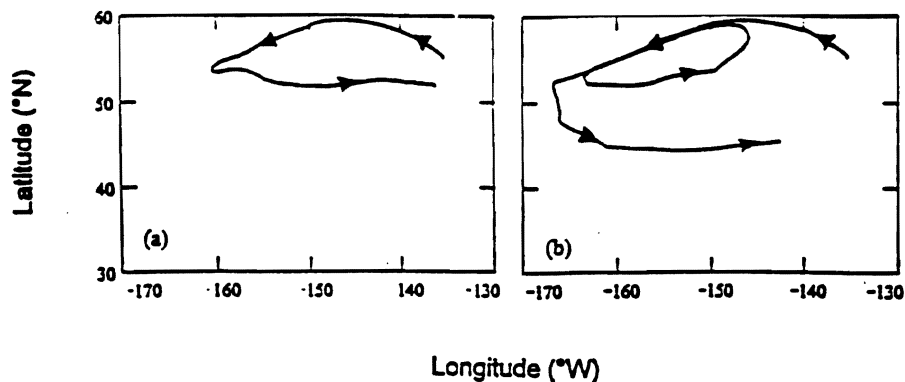

Figure 3. Plots of mean trajectory followed by simulated sockeye moving in accordance with two different sets of migration rules from Aug-00 to June-02 (21.5 months). Swimming speed was 0.3 body lengths/s in all simulations. (a) Preferred direction northwest Aug-00 to Nov-00, random thereafter. (b) Preferred directions northwest for Aug-00 to Nov-00, west for Dec-00 to Feb-01, south for Mar-01 to May-01, east for Jun-01 to Aug-01, north Sep-01 to Nov-01 and repeat series from Dec-00.

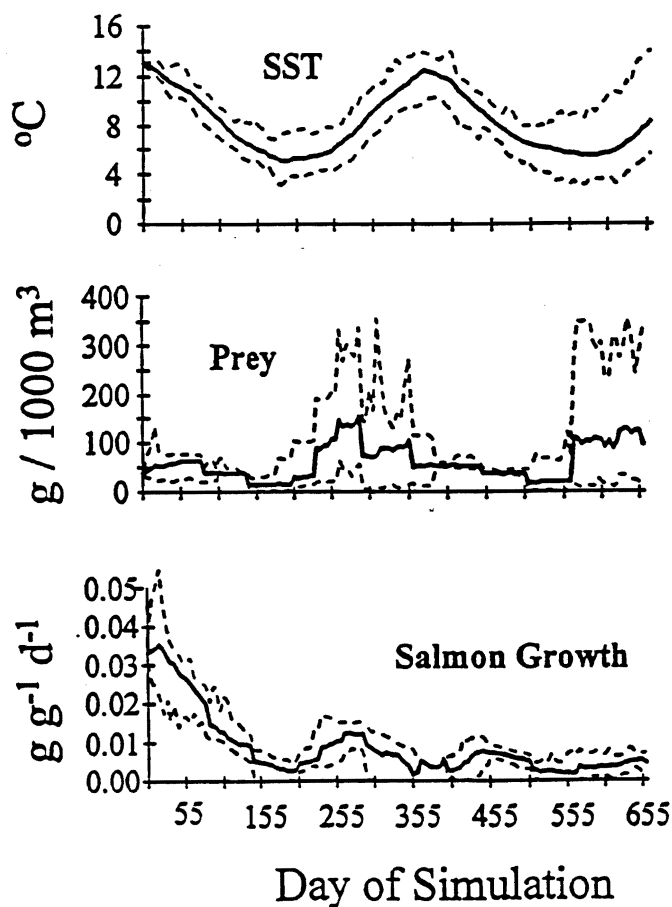

Figure 4. Mean (solid line) and range (dashed line) of exposure to environmental variables and estimated salmon growth rate for 200 salmon in a modeled cohort. Top panel is occupied temperature, middle panel is the history of exposure to prey biomass during the simulation, and bottom panel reflects related growth response by individuals within the population.

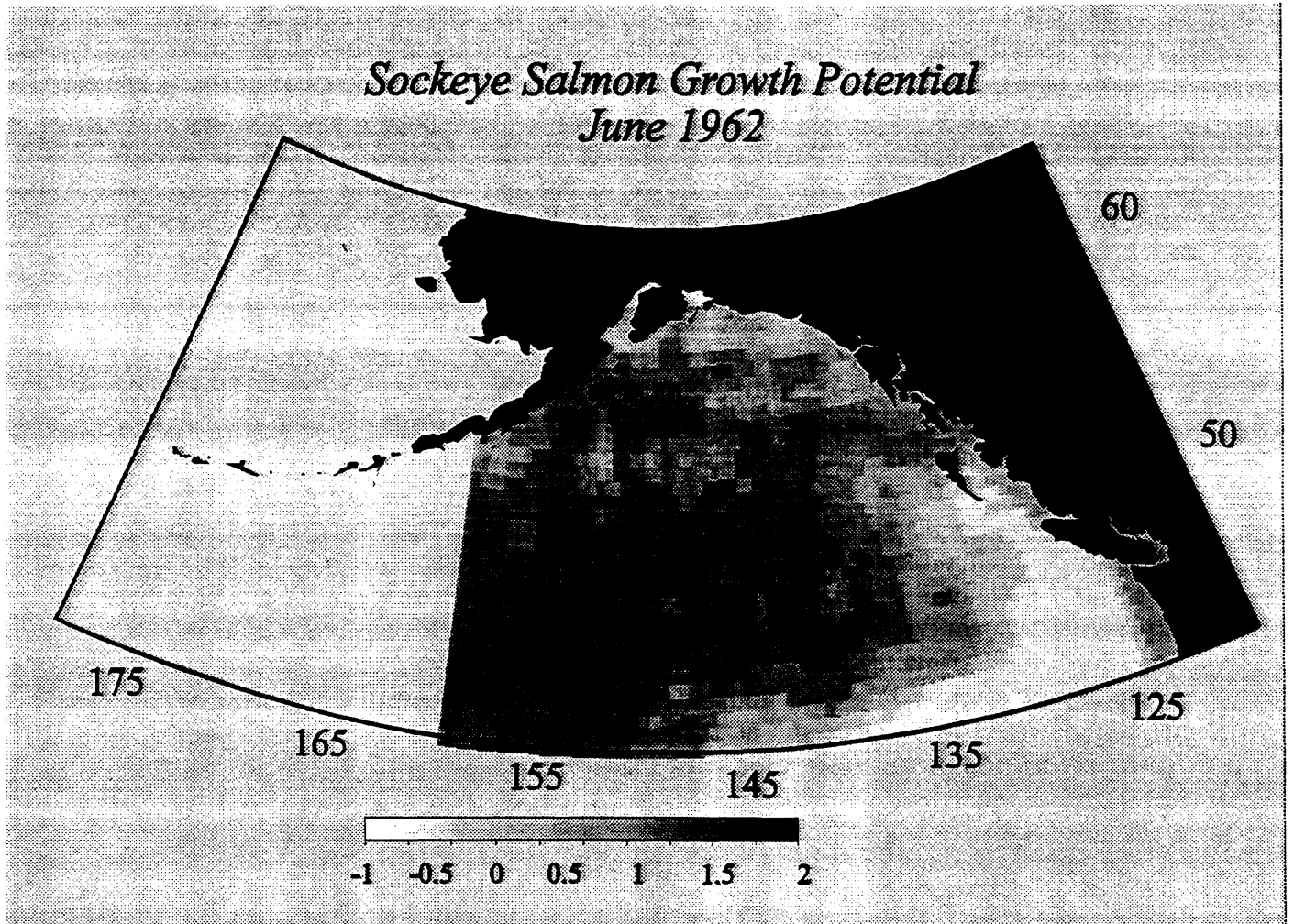

Figure 5. Spatially explicit growth rate potential for a representative 500 g sockeye salmon across the Northeast Pacific Ocean during June 1962. Growth is in percent body weight per day. Note region that supports high growth potential near the center of the gyre, the concentric “rings” of poor growth potential surrounding it, and the sharp reduction in growth potential at southern latitudes.

seas environments. These efforts will culminate in explicit predictions in spatial distribution and growth rates that can be rigorously tested with innovative field programs employing new sampling technologies such as acoustics and smart tags (e.g., MacLennan and Simmonds 1992, DeLong et al. 1992). Although much of what was described above addresses issues related to growth and migration, we intend to apply the model to gain insights into mechanisms responsible for regulating mortality, which is the explicit focus of this scientific conference. We have begun to explore the trade-off between growth and mortality in Pacific salmon using techniques of dynamic programming (Scandol et al. in review). If indeed the critical period in the Pacific salmon life history is during the first month or months at sea, we could gain insights into mechanisms of this process by hindcasting growth conditions in past years. There is a substantial literature that supports the notion that mortality is strongly size dependent, and hence growth conditions experienced by juveniles during this period may serve as an accurate predictor of year-class strength. We are presently working with Canada's Department of Fisheries and Oceans and the Pacific Salmon Commission to compile data sets on smolt migration timing, size distribution, abundance, and subsequent survival rates for select salmon stocks. This information, coupled with our simulation model, may allow us to better explain the observed variance in smolt-to-adult survival.

One element shared by most conference presentations was a deep appreciation for the variability that salmon survival exhibits in both space and time. This became clear through comparisons of salmon survival across, for example, northern vs. southern salmon stocks, pre- vs. post-1977 oceanographic conditions, and El Niño vs. La Niña climate scenarios. This argues for future efforts that explicitly integrate effects of both space and time in the analyses, to help explain changes in growth and survival of these important fish populations. We hope the present effort can be successful at accomplishing this goal to help improve conservation efforts and develop better policies for stock management.

Citations

- Beauchamp, D. A., D. J. Stewart, and G. L. Thomas. 1989. Corroboration for a bioenergetics model for sockeye salmon. *Trans. Am. Fish. Soc.* 118:597-607.
- Brandt, S. B., D. M. Mason, E. V. Patrick. 1992. Spatially-explicit models of fish growth rate. *Fisheries (Bethesda)* 17(2):23-31, 34-35.
- Brodeur, R. D., and D. M. Ware. 1992. Long-term variability in zooplankton biomass in the subarctic Pacific Ocean. *Fish. Oceanogr.* 1:32-38.
- Cox, S. P., and S. G. Hinch. In review. Size at maturity of Fraser River sockeye salmon: Interannual trends and the potential effects of temperature. *Can. J. Fish. Aquat. Sci.*
- DeLong, R. L., B. S. Stewart, and R. D. Hill. 1992. Documenting migrations of northern elephant seals using day length. *Mar. Mammal Sci.* 8:155-159.

- Hewett, S. W., and C. E. Kraft. 1993. The relationship between growth and consumption: Comparisons across fish populations. *Trans. Am. Fish. Soc.* 122:814-821.
- Hinch, S. G., M. C. Healey, R. E. Diewert, K. A. Thomson, R. Hourston, M. A. Henderson, and F. Juanes. 1996. Potential effects of climate change on marine growth and survival of Fraser River sockeye salmon. *Can. J. Fish. Aquat. Sci.* 52:2651-2659.
- LeBrasseur, R. J. 1965a. Biomass atlas of net zooplankton in the northeastern Pacific Ocean, 1956-1964. *Fish. Res. Board Can. Manuscr. Rep. Ser. (Oceanogr. Limnol.)* 201:1-260.
- LeBrasseur, R. J. 1965b. Data Record. Stomach contents of salmon from the northeastern Pacific Ocean, 1958-64. Circular (Statistical Series), Nos. 15-23, Fish. Res. Board Canada, Biological Station, Nanaimo, BC.
- MacLennan, D. N., and E. J. Simmonds. 1992. Fisheries Acoustics. Chapman & Hall Fish and Fisheries Series 5:1-325.
- Mantel, N. 1967. The detection of disease clustering and a generalized regression approach. *Cancer Res.* 27:209-220.
- Scandol, J. P., P. S. Rand, F. Juanes, M. C. Healey, and L. Huato. In review. Examining sockeye salmon growth and survival using dynamic optimisation to solve for bioenergetic activity. *Can. J. Fish. Aquat. Sci.*
- Thomson, K. A., W. J. Ingraham Jr., M. C. Healey, P. H. LeBlond, C. Groot, and C. G. Healey. 1994. Computer simulations of the influence of ocean currents on Fraser River sockeye salmon (*Oncorhynchus nerka*) return times. *Can. J. Fish. Aquat. Sci.* 51:441-449.
- Walter, E. E., J. P. Scandol, and M. C. Healey. In review. Ocean migration patterns of Fraser River sockeye salmon: A reanalysis of accepted patterns. *Can. J. Fish. Aquat. Sci.*
- Welch, D. W., A. I. Chigirinsky, and Y. Ishida. 1995. Upper thermal limits on the oceanic distribution of Pacific salmon (*Oncorhynchus* spp.) in the spring. *Can. J. Fish. Aquat. Sci.* 52:489-503.

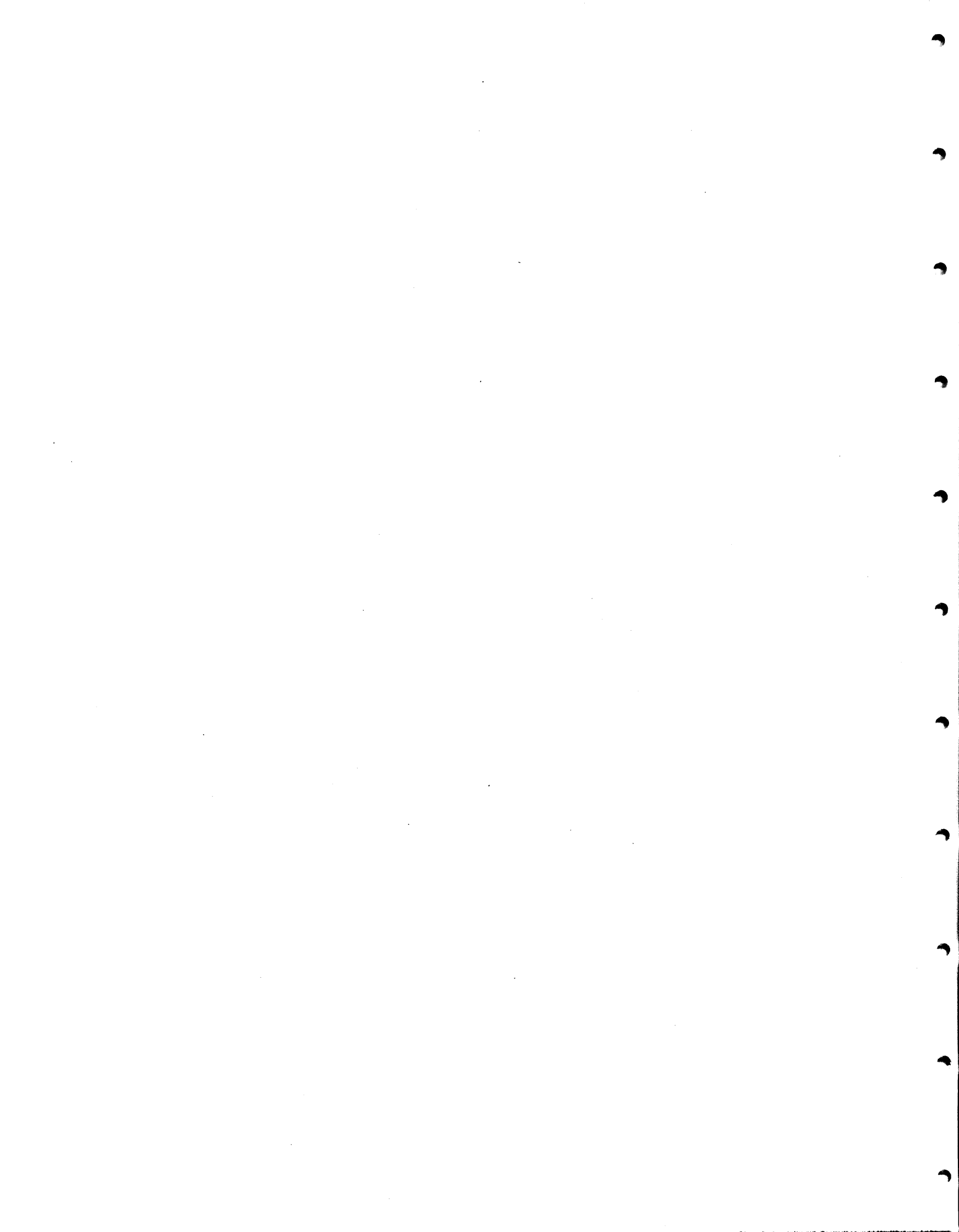

PATTERNS OF COVARIATION IN COMPONENTS OF RECRUITMENT AMONG
SOCKEYE SALMON STOCKS IN BRITISH COLUMBIA AND ALASKA

Randall M. Peterman, Brian J. Pyper, Michael F. Lapointe¹, and Milo D. Adkison²

School of Resource and Environmental Management
Simon Fraser University Burnaby, BC, Canada V5A 1S6

Current addresses:

¹Pacific Salmon Commission
600-1155 Robson St., Vancouver, BC, Canada V6E 1B5

²National Biological Service
1011 East Tudor Road, Anchorage, AK 99503, U.S.A.

Interannual variability can be large for survival rate or body size of adults in stocks of Pacific salmon (*Oncorhynchus* spp.). Within-stock or between-stock density-dependent processes usually explain little of this variation, suggesting that environmental processes are important (Peterman 1987). Our purpose was to identify patterns of covariation across years and among salmon stocks in components of recruitment of fishable biomass, such as survival rate and body size of adults. Such patterns can help characterize the spatial and temporal scale over which environmental processes influence recruitment.

We explored patterns of covariation in two components of recruitment, an index of survival rate and an index of body size of adults, across 21 sockeye salmon (*O. nerka*) stocks from British Columbia (BC) (20 stocks from the Fraser River plus Skeena River, for brood years 1948-86) and 9 sockeye salmon stocks from Bristol Bay, Alaska (brood years 1954-83). Stocks from these two regions overlap for much of their marine life history. For each stock, an index of survival rate was calculated to account for lognormal error structure and correct for possible within-stock density-dependent effects. This index was the brood-year residuals from a Ricker stock-recruitment model fit by linear regression of $\log_e(\text{recruits per spawner})$ vs. spawners. The index of body size was average length of female spawners by age.

Correlation coefficients were calculated for pairwise comparisons among the 21 BC stocks (210 possible comparisons), among the 9 Bristol Bay stocks (36 possible comparisons), and between the BC and Bristol Bay stocks (189 possible comparisons) for a) the survival index calculated for sub-2 returns (e.g., age 4₂ and 5₂ fish) by brood year and b) length data for age 4₂ female spawners by brood year. In addition, to determine which lifestage, freshwater or marine, may be the largest contributor to interannual variability, within-stock comparisons for Bristol Bay stocks were made by correlating the survival rate of sub-2 and sub-3 returns with a) the same brood year and b) the same ocean-entry year (OEY). For body size, these same within-stock correlations were done in addition to correlations between sub-2 and sub-3 fish with the same return year.

There were large positive correlations in survival rate index among the Bristol Bay stocks and, to a lesser extent, among the BC stocks, with a tendency toward negative correlations between Bristol Bay and BC stocks (Fig. 1). This suggests that within each region (i.e., Bristol Bay or BC) the interannual variability in survival rate of sockeye stocks is influenced by common environmental processes, but that these processes are distinct for the stocks of each region. For eight of the nine Bristol Bay stocks, the survival index of sub-2 adults was more highly correlated (average $r = 0.47$) with the survival index of sub-3 adults of the same stock that had the same ocean-entry year versus adults that had the same brood year (average $r = 0.25$). This indicates that the late freshwater or early marine lifestage (shared by age groups with the same OEY) may be more important than the early freshwater lifestage (shared by age groups with the same brood year) for determining variability in survival rate.

Body size tended to be positively correlated among BC stocks and Bristol Bay stocks, but there was no consistent correlation between Bristol Bay and BC stocks (Fig. 2). As with the survival index, these results suggest that environmental processes influence the interannual variability in body size of adult sockeye within each region, but not between regions. For the Bristol Bay stocks, within-stock correlations of lengths of female spawners were all positive and large between age groups that shared the same return year and OEY (e.g., age 4_2 vs. 5_3 and 5_2 vs. 6_3 , average $r = 0.66$). However, for age groups that shared the same brood year and OEY but not the same return year, the correlations were considerably weaker (e.g., 4_2 vs. 5_2 , and 5_3 vs. 6_3 , average $r = 0.19$). This suggests that the final year of ocean residence (shared by age groups with the same return year) is the most critical period for determining interannual variability in age-specific size of adults.

Patterns of covariation can also be examined by fitting different types of models that include environmental effects to data for the residuals in $\log_e(\text{recruits/spawner})$ (details given in Adkison et al. in press). For Bristol Bay sockeye salmon, the best-fit model was a one-time shift in parameters of the Ricker stock-recruitment curve, coinciding with the rapid change in the mid-1970s in intensity of the Aleutian low-pressure weather systems and associated wind-driven processes (Trenberth and Hurrell 1994, Hare and Francis 1995). On average across the nine Bristol Bay sockeye salmon stocks, the Ricker 'a' parameter (an index of productivity) increased threefold between the early and late 1970s, whereas the Ricker 'b' parameter did not change appreciably or consistently among stocks. This increased productivity is consistent with Brodeur and Ware's (1992) finding that zooplankton abundance increased between those two periods in the Gulf of Alaska.

These results suggest that large-scale environmental processes can strongly influence survival and growth rates of sockeye salmon. Analyses of historical data as well as forecasts by management agencies and the fishing industry must therefore take the spatial and temporal scales of those environmental processes into account.

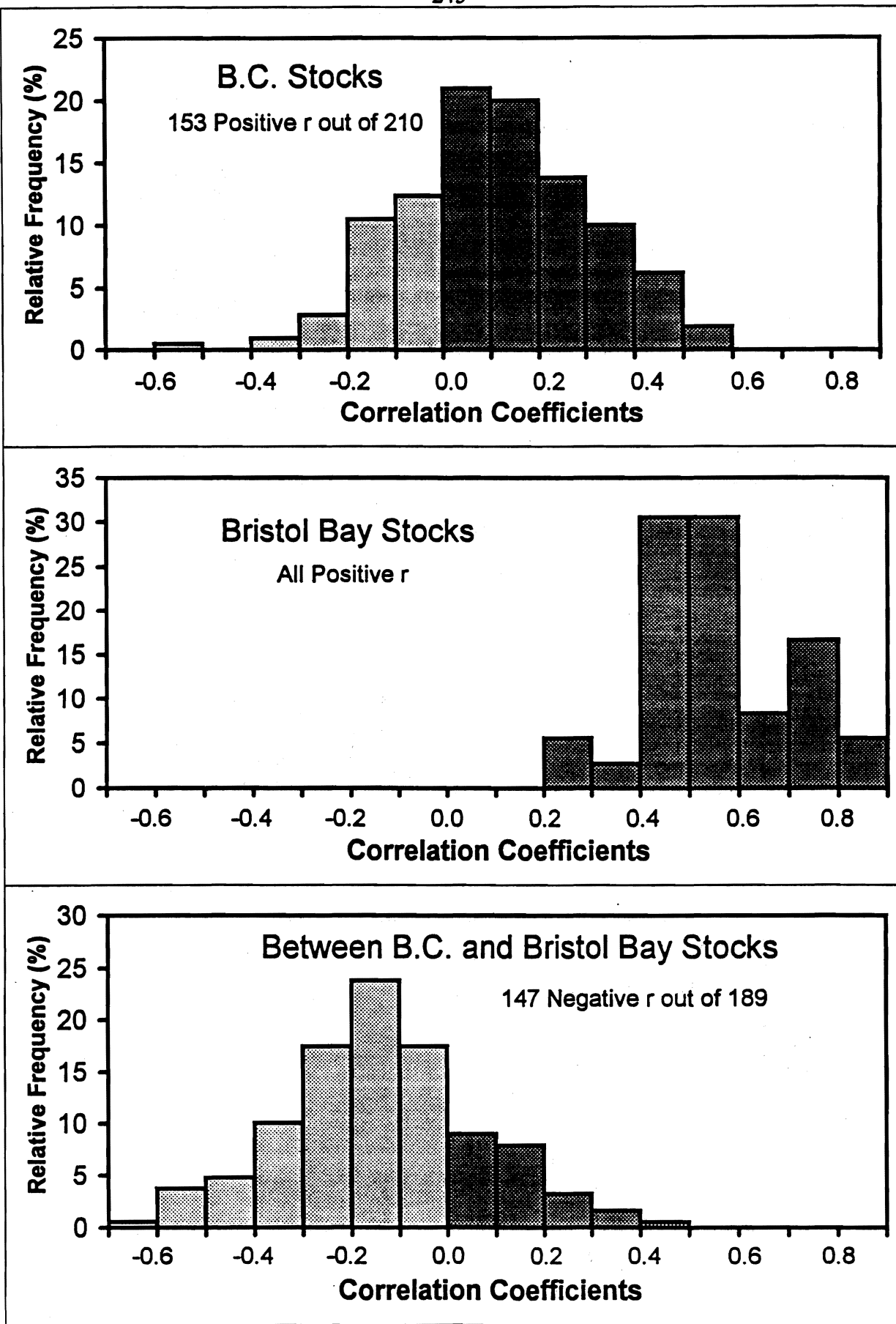

Figure 1. Frequency distributions of correlation coefficients (r) for the survival rate index (residual from the Ricker stock-recruitment curve) among BC stocks (top panel), Bristol Bay stocks (middle panel), and between BC and Bristol Bay stocks (bottom panel).

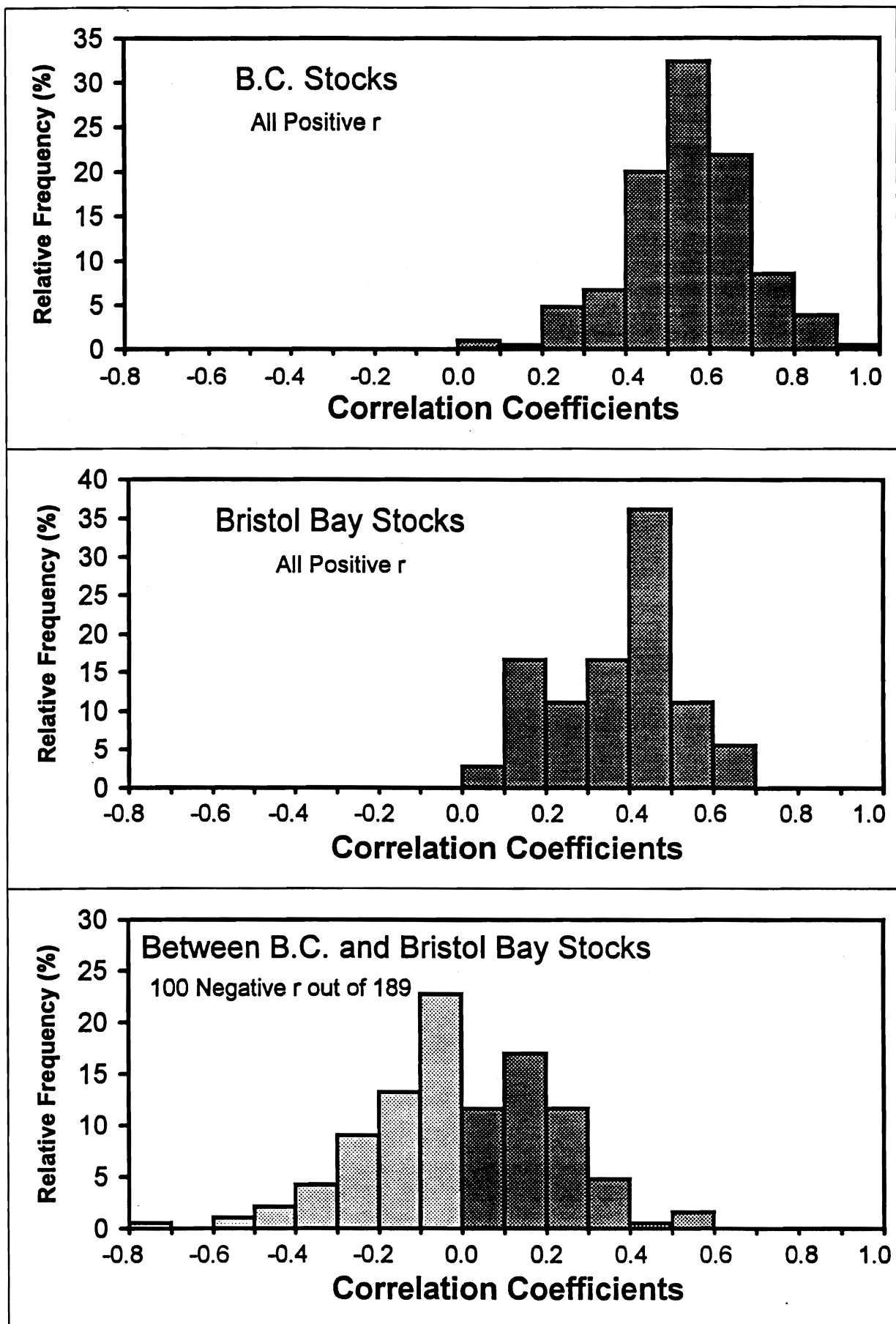

Figure 2. Frequency distributions of correlation coefficients (r) for lengths of age 4_2 female spawners among BC stocks (top panel), Bristol Bay stocks (middle panel), and between BC and Bristol Bay stocks (bottom panel).

Funding was provided by grants to R. M. Peterman from the Ocean Production Enhancement Network, one of Canada's Networks of Centres of Excellence, and the Natural Sciences and Engineering Research Council of Canada.

Citations

- Adkison, M. D., R. M. Peterman, M. F. Lapointe, D. M. Gillis, and J. Korman. In press. Alternative models of climatic effects on sockeye salmon (*Oncorhynchus nerka*) production in Bristol Bay, Alaska, and the Fraser River, British Columbia. *Fish. Oceanogr.* 5.
- Brodeur, R. D., and D. M. Ware. 1992. Interannual and interdecadal changes in zooplankton biomass in the subarctic Pacific Ocean. *Fish. Oceanogr.* 1:32-38.
- Hare, S. R., and R. C. Francis. 1995. Climate change and salmon production in the Northeast Pacific Ocean. *In* R. J. Beamish (editor), *Climate change and northern fish populations*. *Can. Spec. Publ. Fish. Aquat. Sci.* 121:357-372.
- Peterman, R. M. 1987. Review of the components of recruitment of Pacific salmon. *In* M. Dadswell, R. Klauda, C. Moffitt, R. Saunders, R. Rulifson, and J. E. Cooper (editors), *Common strategies of anadromous and catadromous fishes*, p. 417-429. *Am. Fish. Soc. Symp.* 1.
- Trenberth, K. E., and J. W. Hurrell. 1994. Decadal atmosphere-ocean variations in the Pacific. *Climate Dynamics* 9:303-319.



GROWTH AND ENERGETICS OF SALMON IN THE SEA

David W. Welch

Ocean Sciences and Productivity Division
Department of Fisheries and Oceans
Pacific Biological Station
Nanaimo, BC Canada V9R 5K6

Interest is growing in the question of whether the ocean as well as fresh water can limit Pacific salmon (*Oncorhynchus* spp.) production. Both the North Pacific marine science organization, PICES, and the North Pacific Anadromous Fish Commission (NPAFC) have on their research agendas proposals to develop joint international efforts to try to answer this question. It is likely that there are few more technically difficult questions to answer in fisheries oceanography and few that are of potentially greater importance to salmon-producing countries.

The primary effects of the ocean on salmon productivity involve both growth and survival of salmon. The decline in salmon survival in Washington and Oregon since 1977 is probably caused by as yet poorly understood processes in the marine (as opposed to freshwater) environment. The need to understand the causes of survival variations in fish are apparent; however, comparatively little effort has been focused on understanding the changes in growth that have occurred. Variation in growth has been assumed to be of relatively little importance to the regulation of productivity in fish populations in general. Yet, body size at maturity directly affects the meat yield of salmon and indirectly, and probably even more important, the biological productivity: changes in fecundity, average age at maturity, and ability to swim upriver and prepare and defend nest sites (Forbes and Peterman 1994).

Salmon are fundamentally marine animals whose reproduction is tied to fresh water. Viewed as a whole, salmon spend most of their lives getting out of fresh water. Most species probably do not even remain in the coastal environment for any significant time, instead using the coastal environment as a transit zone during their passage offshore and again on the return trip inshore to spawn.

From a Darwinian viewpoint, this behavior is interesting. It suggests that there are great benefits to getting to the offshore pelagic zone as quickly as possible. Because our most productive species are pink (*O. gorbuscha*), chum (*O. keta*), and sockeye (*O. nerka*) salmon (which spend the smallest amount of time in coastal waters), this suggests that the offshore open ocean is the most productive environment. However, since the productivity of the offshore is much lower than the coastal region per unit area, salmon must move offshore to either reduce rates of predation or increase growth rates because of density-dependent interactions in the coastal zone, or both.

In the following sections, I review some of the evidence that a) salmon show sharp thermal limits which appear to be the result of reducing their basal metabolic rates in times of low food abundance, b) significant changes in rates of annual growth occur in the ocean, c) density-dependent changes in growth are limited to the first and last years of life in the ocean when salmon must pass through the coastal zone to the offshore, and d) evolutionary selection has resulted in extremely sensitive responses by salmon to factors affecting their growth rates in the offshore areas.

Effects of Ocean Temperature

Between 1955 and the late 1960s, Canada, Japan, and the United States mounted an intensive ocean research program on the distribution of Pacific salmon. It was during this time that North American scientists first discovered that salmon undertook extensive ocean migrations and were not simply residents of the nearshore coastal zone during the marine phase of their life history.

Although substantial effort was put into ocean surveys of salmon, there was little evidence of strong limits to the distribution of salmon until recently. However, evidence for quite strong thermal limits on their ocean distributions was found during a survey of salmon distributions in the spring of 1990 (Welch et al. 1995). Based on these preliminary results, Canada and Japan mounted a series of 11 one-month surveys in 1992 to further examine the limits on the salmon distribution in different seasons and areas of the North Pacific. In addition, we supplemented these surveys by combining all of the available Canadian and U.S. salmon surveys for the 1950s and 1960s, and the more limited data collected by Canada in the 1980s and 1990s. An extensive data set was also available from Japan, which has been conducting substantial salmon surveys since 1972. (Surveys for prior years are available, but they are not amenable to computer analysis.)

The geographic distribution of this data set, which comprises some 20,636 observations on ocean salmon abundance, is shown in Figure 1. At each location, the catch of each species of salmon is recorded, along with the amount of fishing effort and a number of oceanographic variables, chiefly sea surface temperature (SST).

Our current findings indicate that the primary control on salmon distribution is temperature, but that the upper thermal limit varies throughout the year. To illustrate this point, Figure 2a-c shows the distribution of $\log(\text{salmon catch})$ against SST, but with the catches split out in a trellis plot by five decades (rows) and four geographic regions (columns) for three seasons of the year: winter, spring, and summer. (We actually plot $\ln(\text{catch}+1)$ to preserve the zeros in the log transformation.) Figure 2a-c refers specifically to sockeye salmon, but our general findings also apply to all the other species of Pacific salmon. Although the temperature defining the thermal limit in any given month differs significantly between species in the spring and summer, and shows some smaller variation between

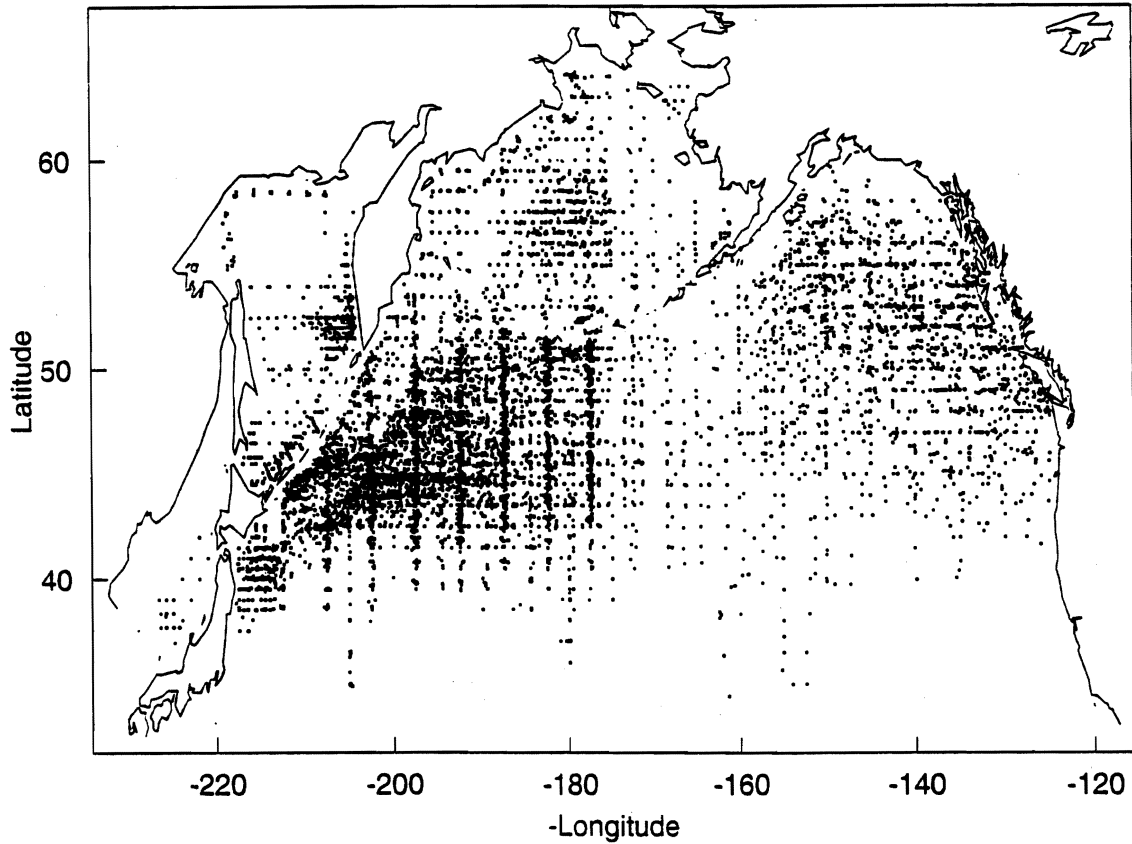

Figure 1. The geographic distribution of 20,636 observations on abundance (catch per unit effort) for each species of Pacific salmon (*Oncorhynchus* spp.) At each location, information on temperature and a limited range of other data were collected. The true density of the data set is not well represented in this plot because many stations are overplotted dozens of times (from Welch, Ishida, and Nagasawa; submitted to *Science*).

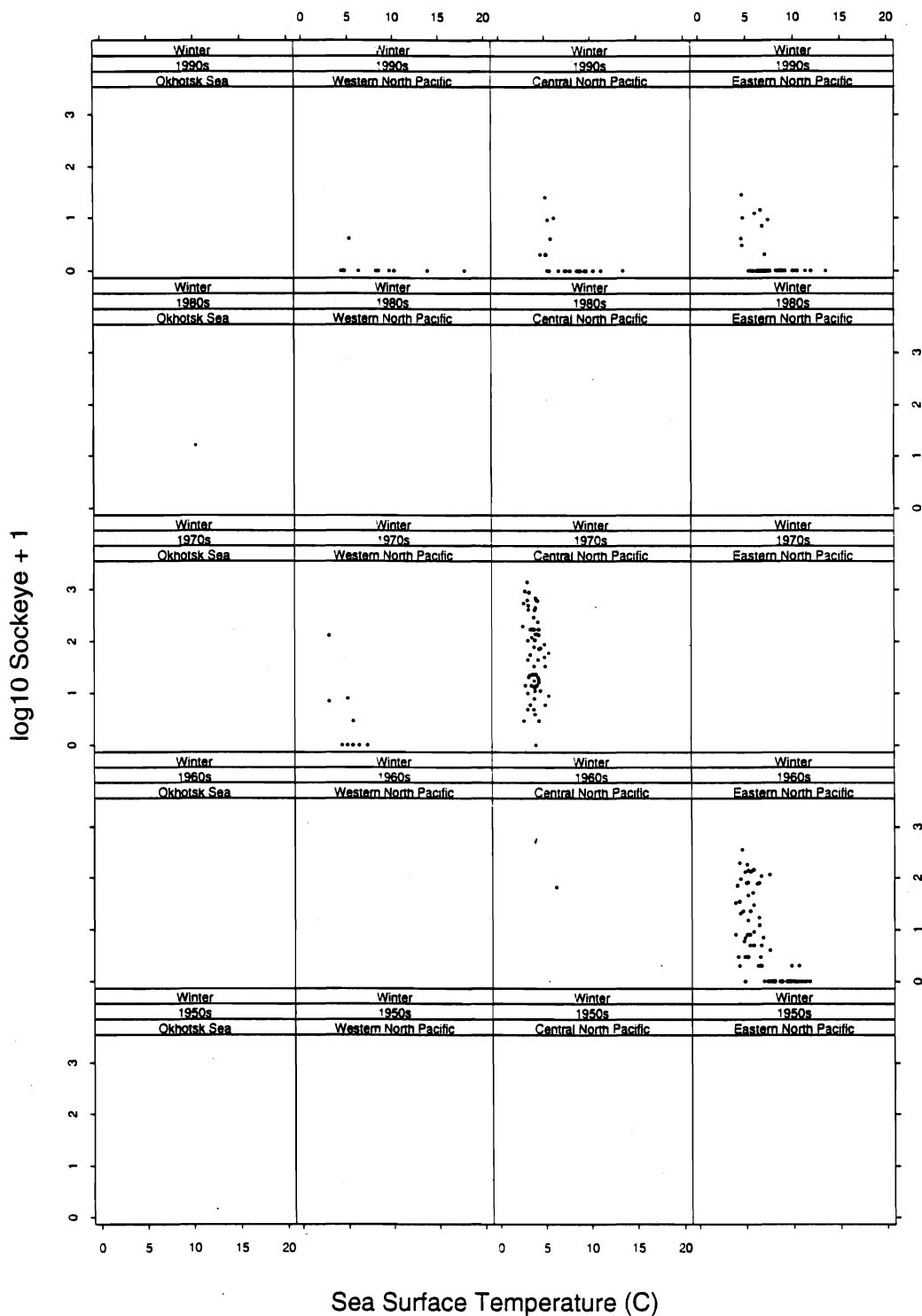

Figure 2a. A comparison of $\ln(\text{sockeye catch} + 1)$ vs. temperature, splitting out the data by season (winter: N,D,J,F,M; spring: A,M,J; summer: J,A,S). Note the sharpness of the upper thermal limit on salmon abundance. In most cases the salmon density drops by two orders of magnitude in a fraction of a degree Celsius. The temperature defining the upper thermal limit varies throughout the year in a regular cycle, but in all months it is well below lethal temperatures ($>20^{\circ}\text{C}$) (Brett 1956). (From Welch, Ishida, and Nagasawa; submitted to *Science*.)

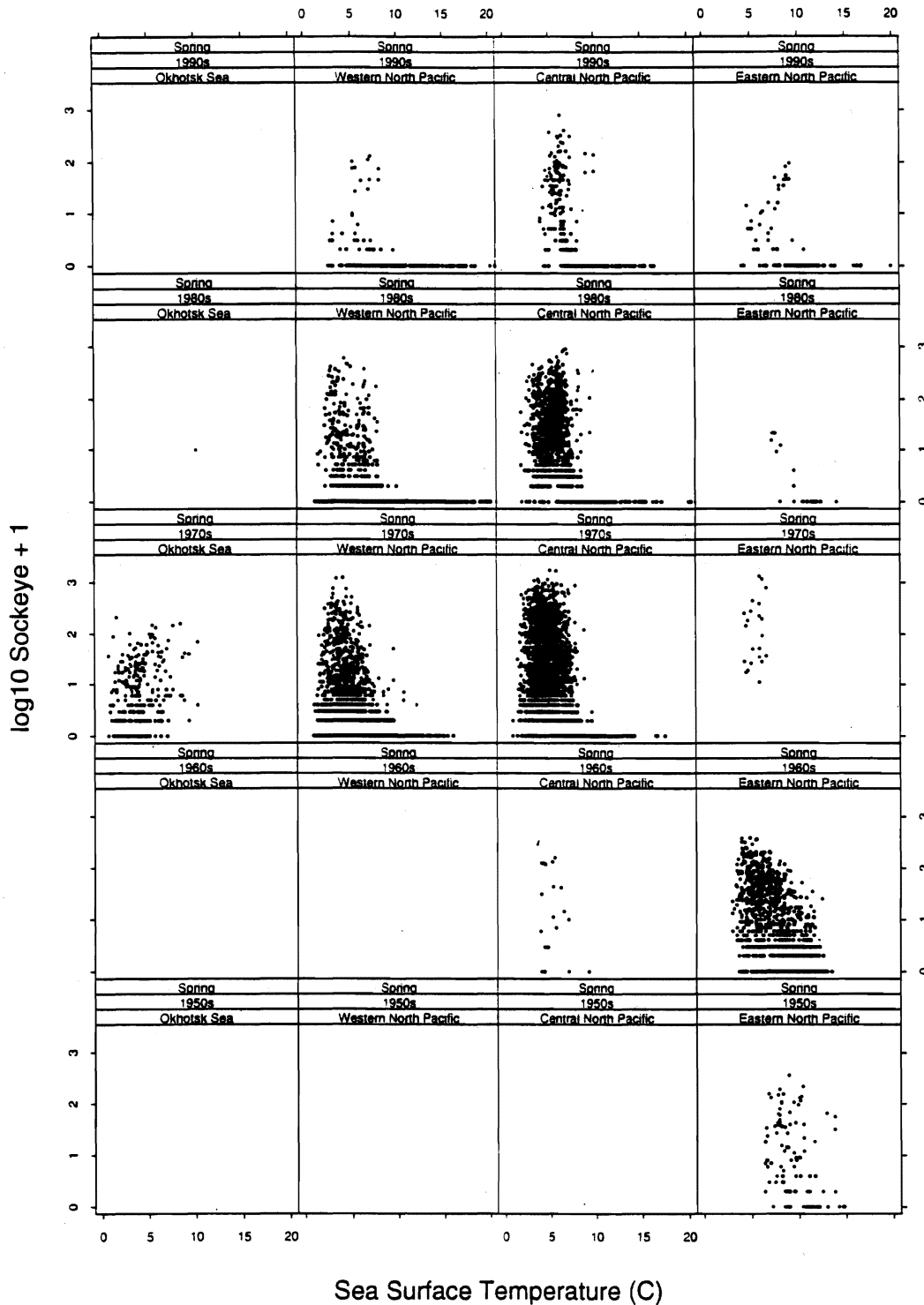

Figure 2b. A comparison of $\ln(\text{sockeye catch} + 1)$ vs. temperature, splitting out the data by season (winter: N,D,J,F,M; spring: A,M,J; summer: J,A,S). Note the sharpness of the upper thermal limit on salmon abundance. In most cases the salmon density drops by two orders of magnitude in a fraction of a degree Celsius. The temperature defining the upper thermal limit varies throughout the year in a regular cycle, but in all months it is well below lethal temperatures ($>20^{\circ}\text{C}$) (Brett 1956). (From Welch, Ishida, and Nagasawa; submitted to *Science*.)

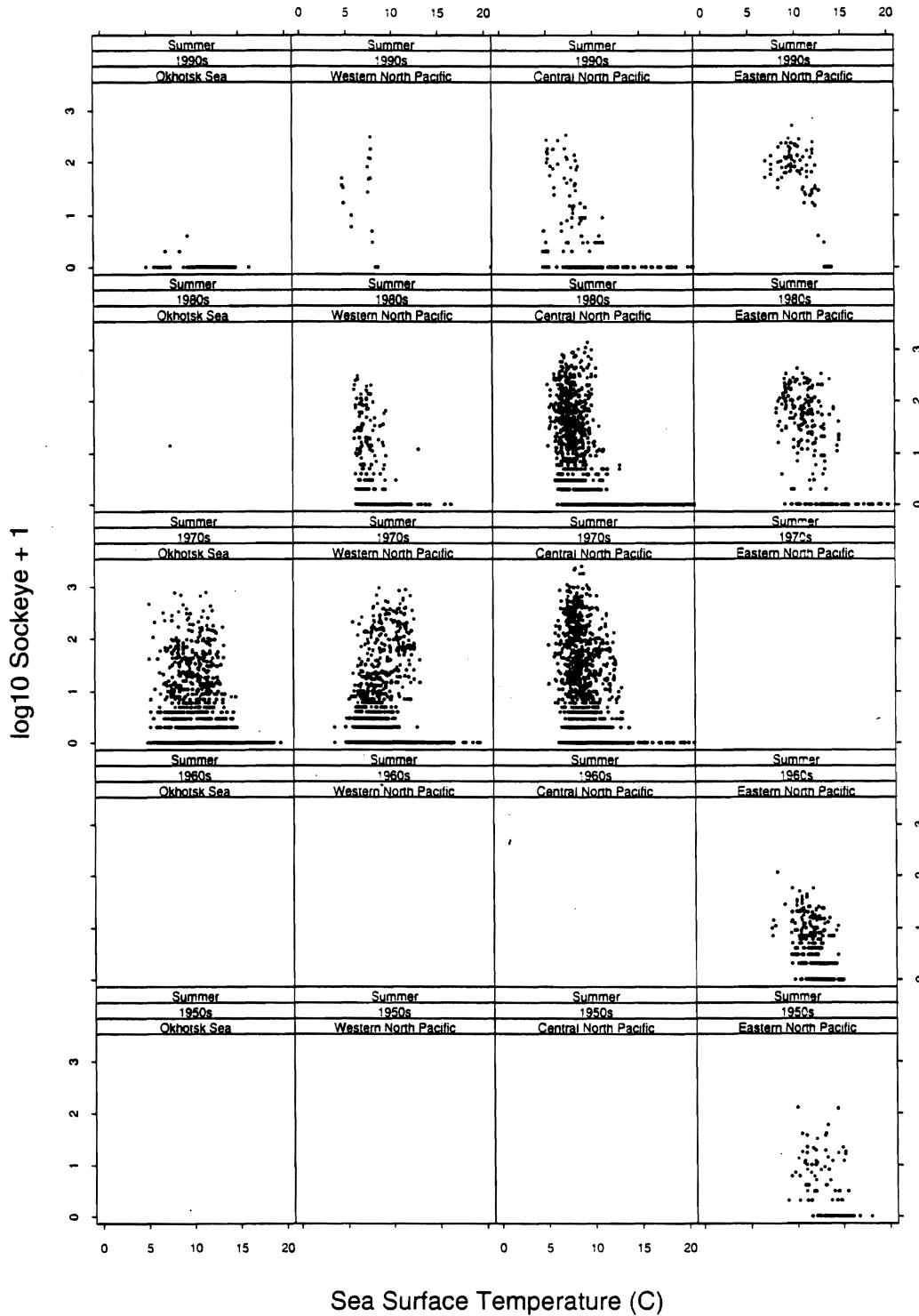

Figure 2c. A comparison of $\ln(\text{sockeye catch} + 1)$ vs. temperature, splitting out the data by season (winter: N,D,J,F,M; spring: A,M,J; summer: J,A,S). Note the sharpness of the upper thermal limit on salmon abundance. In most cases the salmon density drops by two orders of magnitude in a fraction of a degree Celsius. The temperature defining the upper thermal limit varies throughout the year in a regular cycle, but in all months it is well below lethal temperatures ($>20^{\circ}\text{C}$) (Brett 1956). (From Welch, Ishida, and Nagasawa; submitted to *Science*.)

decades and areas of the ocean, the existence and remarkable sharpness of this limit is the same in all species.

With the exception of October, when we have no data, a thermal limit is evident in all months. For the "winter" months of November through March, sockeye are confined to ocean regions of $<7^{\circ}\text{C}$. These thermal limits then begin to change, with the thermal limits increasing from April through September, when they reach a maximum of about 15°C . Thermal limits then begin to decline again until they finally reach the 7°C level by November. Unfortunately, the paucity of data in the autumn prevents us from fully defining how salmon respond to temperature during the fall, as their thermal limits must cycle back to the winter temperature limits.

What is most remarkable about this extensive data set is just how sharp these thermal limits are, particularly when we consider that the data extend over five decades and include data from all parts of the North Pacific Ocean and the Okhotsk Sea. (Temperatures in the Bering Sea never increased to levels of thermal limits recorded in the other regions of the North Pacific.)

In British Columbia (BC) alone, there are approximately 3,150 genetically separate stocks of the five most abundant species of salmon (Healey 1982). British Columbia formerly produced about 15% of the total salmon from the North Pacific Ocean, which makes for a rough estimate of 21,000 genetically separate salmon stocks occupying the North Pacific. As the thermal limits are extremely sharp for all species, with abundances dropping by one to two orders of magnitude in approximately 1°C , essentially all genetically separate stocks must be responding to the same thermal limit--otherwise, such a sharp drop in abundance would not be observed across so many populations. Whatever the specific causes of the thermal limits are, their effects on productivity and survival for each species must be very large, or such uniformity in the response to temperature would not be observed.

What is not clear is how such a sharp response can also exist if the different stocks have different patterns of spatial distribution, since this would presumably make their thermal limits different. Perhaps the stocks differentially distribute themselves within the salmon distribution not only relative to temperature, but also in such a way as to minimize their competition for food and thereby maximize their growth rates (see below), thereby smoothing out local variation in the relative abundance of different stocks.

The sharpness of the roll-off in salmon abundance with temperature is best shown by example (Fig. 3, from Welch et al. 1995). Applying the observed roll-off in abundance with temperature to the observed temperature field present in the spring of 1990, all species of salmon show extremely sharp declines in abundance with temperature. (The survey area shown covered most of the central and southern Gulf of Alaska, out to about 300 nautical miles west of Station Papa, or 2,000 km from east to west, and 1,300 km from north to south.)

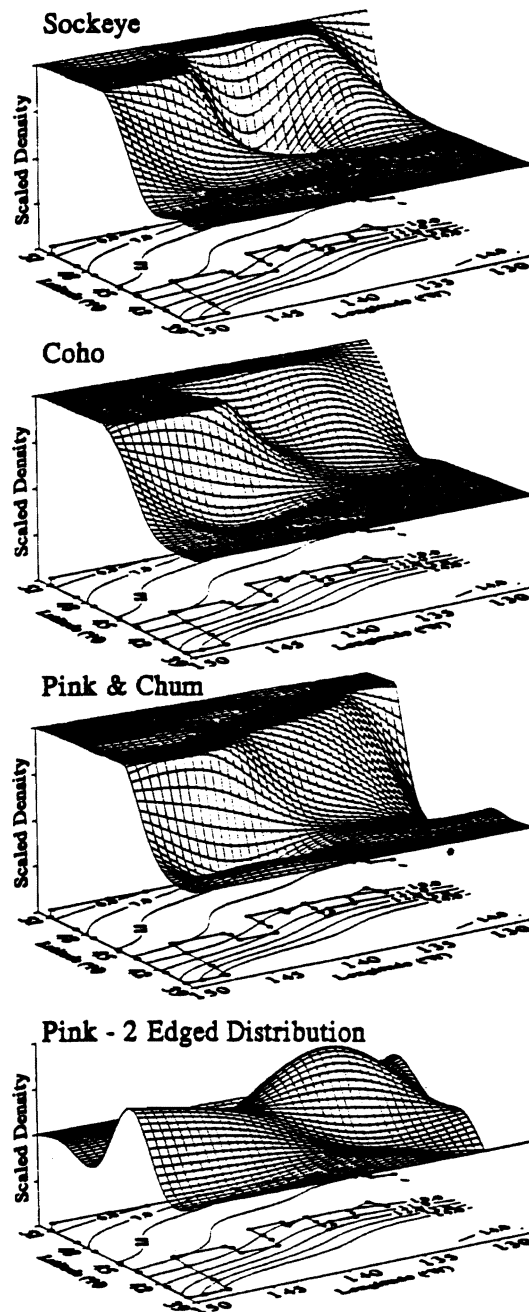

Figure 3. The predicted geographic distribution of salmon in April 1990, based on the R/V *TINRO* data. Contour plots show the predicted temperature field, while the surface plot shows the predicted mean response of salmon abundance to temperature. Fine details in the abundance surfaces are dependent on the accuracy of the interpolation of the temperature field (from Welch et al. 1995).

General circulation models of the world's atmosphere predict that the oceans will warm by 2°-3°C as the carbon dioxide content of the atmosphere doubles. What will happen to the available thermal habitat (ATH) for salmon under a doubling of atmospheric CO₂? The predicted effect of this level of warming is quite surprising. The ATH is predicted to shrink dramatically in both summer and winter (Fig. 4), raising the prospect that salmon will be pushed out of the subarctic Pacific, increasing trophic competition and potentially reducing growth rates. Thus, although much attention has been paid to the possibility that some stocks of salmon near the southern end of their freshwater distribution may be disrupted (Fraser River sockeye being a prime candidate (Levy 1992)), events happening in the marine phase may be even more disruptive. At present, we have no evidence for BC salmon entering the Bering Sea, apart from some stocks of chinook.

If the oceans warm past these sharply maintained thermal limits, BC, Washington, and Oregon salmon would appear to have three choices: 1) develop (or express) the ability to migrate into the Bering Sea (and return), 2) begin to vertically migrate to stay below the permanent thermocline at about 100 m, or 3) simply incur the energetic or other penalties that they now strongly avoid by remaining at higher temperatures.

We have no way of establishing at present which of these three mechanisms may occur, but it seems safe to assume that since such behavior does not seem to occur now, expressing this behavior in the future will have negative effects on salmon production. And as BC salmon are distributed in the Gulf of Alaska, where there is no route into the Bering Sea except at the farthest western extent of their distribution, it would seem reasonable that further study of these possibilities is called for. It is also of some interest that marine survival of Atlantic salmon (*Salmo salar*) has been correlated with interannual variation in the size and position of 4°-8°C water in the North Atlantic (Friedland et al. 1993).

Thermal migrations and growth maximization in the ocean

The observed thermal limits are, however, qualitatively consistent with that predicted by Welch et al. (1995), who suggested that salmon could maximize their growth rates by lowering their body temperature and reducing basal metabolic rates in those seasons when food levels are lower. By doing so, salmon increase the amount of food energy left for growth, and thereby increase their somatic growth rates to a greater extent than would otherwise be possible if they remained at constant temperature (Brett 1956, 1971). There is also substantial evidence that fish placed in thermal gradients in the laboratory move to that temperature yielding maximum growth rates (reviews by Beitinger and Fitzpatrick 1979, Brett et al. 1969).

Unfortunately, this neat qualitative picture tends to fall apart in the details--the field data are in some ways *too* good. Graphs of growth rate vs. temperature show a roughly parabolic and symmetric response of growth to environmental temperature (Brett et al. 1969), so a 1°C increase or decrease in temperature from that giving the maximum growth rate

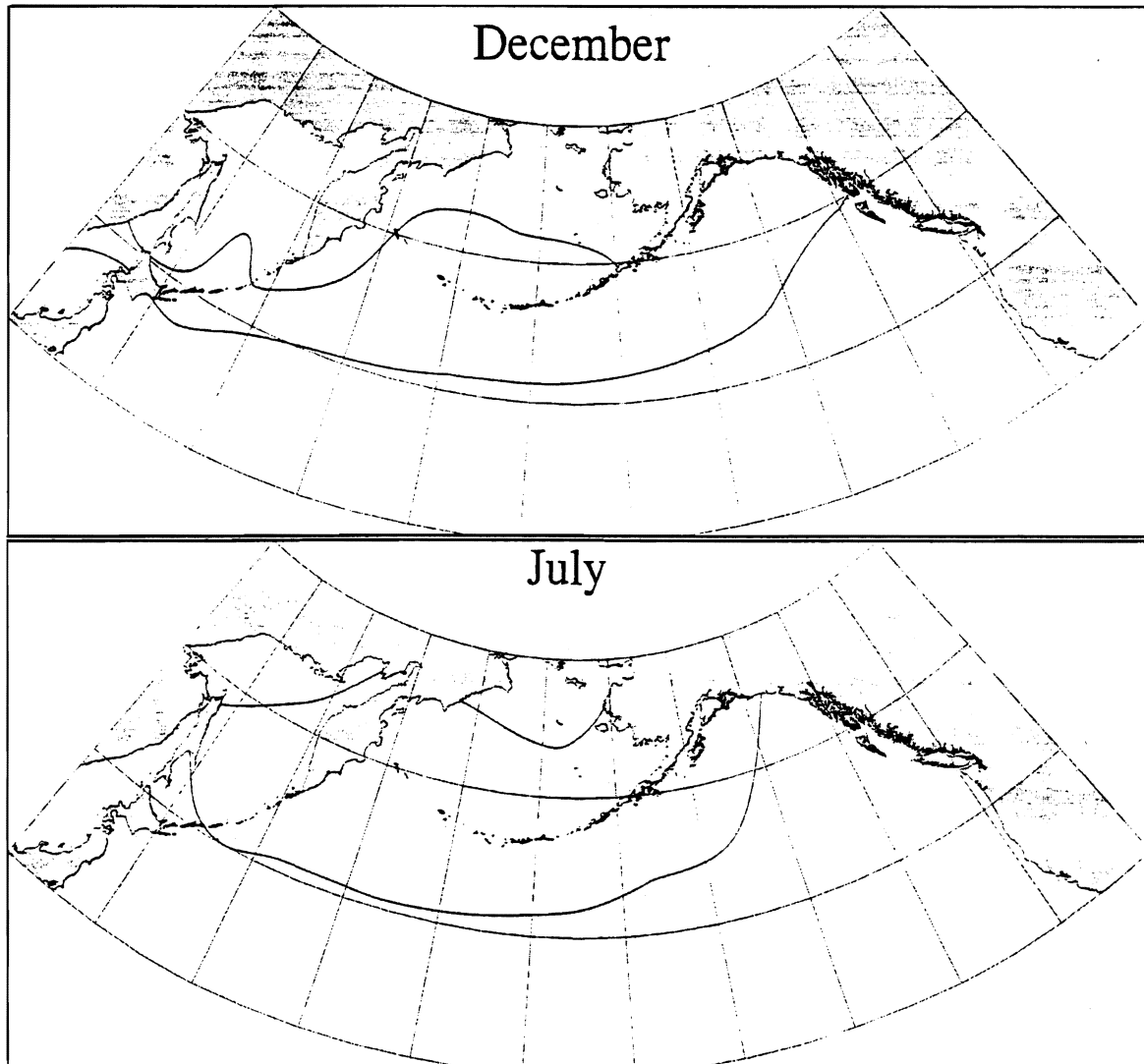

Figure 4. A comparison of the predicted distribution of sockeye salmon under current and future climates (December: 7°C; July: 10°C). Under a doubling of CO₂, predicted to occur around the year 2070 if current trends continue, the distribution of Pacific salmon is predicted to be drastically reduced, and thermal habitat in the North Pacific Ocean virtually eliminated. The SST predictions are based on the Canadian Climate Centre's coupled ocean-atmosphere general climate model (Boer et al. 1992, McFarlane et al. 1992) (from Welch, Ishida, and Nagasawa; submitted to *Science*).

should cause a similar reduction in growth rate. The response of each species of salmon to temperature is clearly a step-function--temperature has no measurable effect on abundance in the interior of the distribution (away from the edge), yet all individuals are stopping in a fraction of a degree Celsius at the edge. The sharpness of the edge is inconsistent with growth maximization, although the qualitative prediction is correct. It may be that salmon simply distribute themselves in areas where they do not incur a growth *deficit*; that is, as long as growth rate is positive, salmon forage independently of temperature. However, I think that the key point for this workshop is that if all species and genetic populations of salmon are responding with such exquisite sensitivity to factors affecting growth, then such factors may play a very large role in the evolutionary biology, and therefore productivity.

Growth variations in salmon

Almost all salmon growth is completed in the ocean, and the final size of salmon at return can be measured relatively accurately. In addition, the growth of scales leaves a permanent record of the amount of growth achieved in different years at sea and, therefore, allows us to partition the integrated growth of the body between years at sea. In essence, although we do not know what the migration pathways of salmon are at sea in any detail, the scale growth records allow us to treat salmon as biological conductivity, temperature, and depth (CTD) sensors which go out to sea and record growth conditions in their scales. If we cannot identify the influential oceanographic factors for growth, it seems unlikely that we will ever be able to identify important factors for survival, given the difficulty with accurately measuring the latter.

Figure 5 shows an idealized input-output sketch of the relationship between salmon growth and a variety of underlying factors in the ocean, viewing the ocean as a chemostat. Fish growth will not reach its maximum potential if food density (food available divided by ocean volume) is insufficient to provide the maximum daily ration. If this critical level of food is *not* exceeded, then the potential for the oceans to limit salmon growth exists. As the examples shown later demonstrate, food availability in the ocean appears to be limiting growth because there are large year-to-year variations in salmon size at maturity.

At food levels below critical, a general framework can be erected to describe how salmon growth can be impacted. First, physical factors may change the productivity of the oceans from year to year, changing the amount of food available. Second, if the geographic distribution of salmon is limited, physical forcing of the southern (or northern) boundaries can change the area available for grazing. Variation in physical variables can then impact salmon growth by changing the amount of available habitat from year to year. Third, ocean temperature may affect growth by increasing basal metabolic rates at higher temperatures, resulting in less energy being available for growth. Finally, the number of salmon entering the ocean may impact growth through competition for the available food.

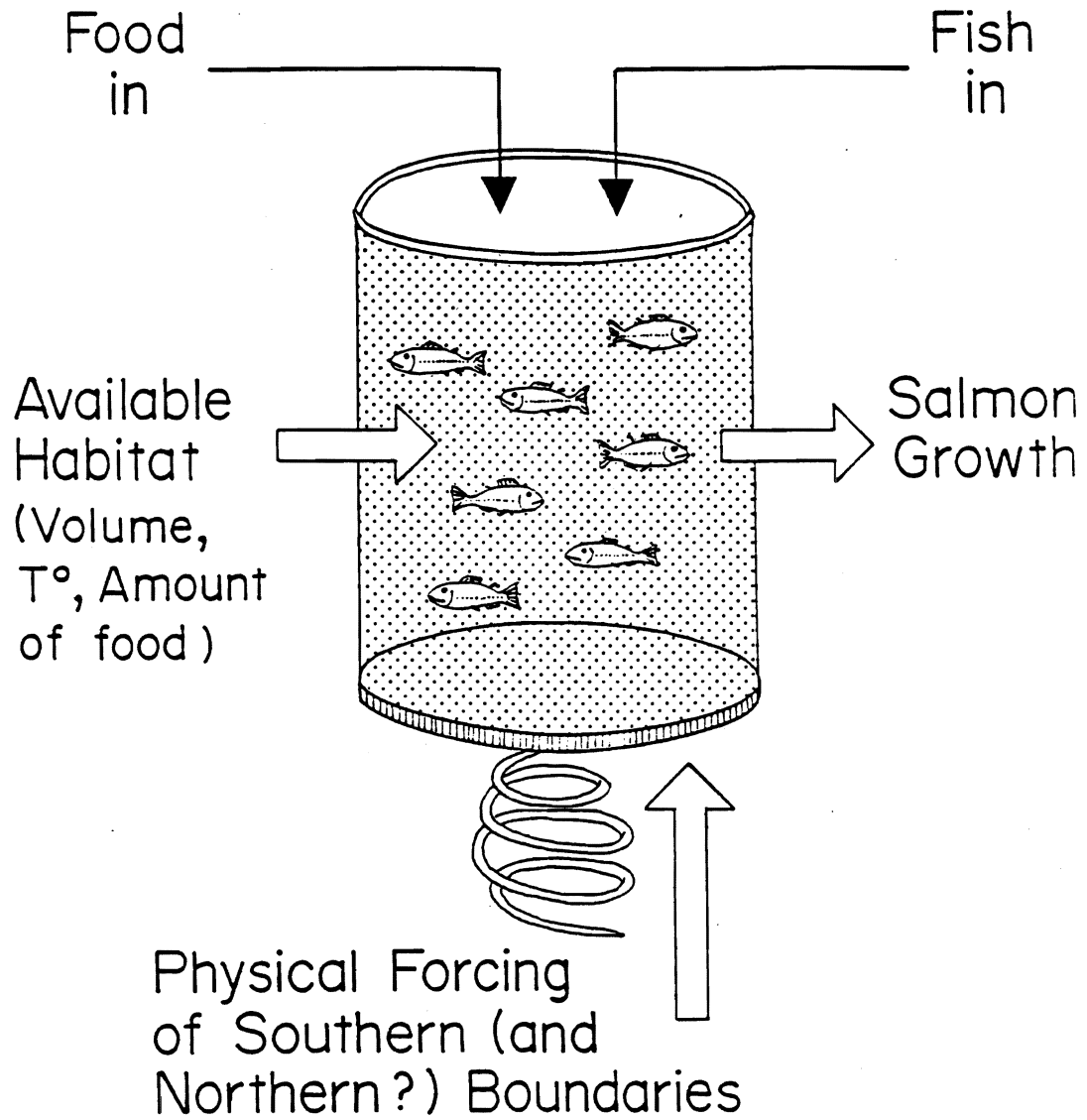

Figure 5. The effect of the ocean on salmon growth, viewing the ocean as a chemostat.

All of these factors may impact growth. However, only the number of salmon entering the ocean is amenable to human intervention (through manipulation of adult escapement and ocean ranching), although it is an important variable. Increases in salmon abundance by one country may reduce the growth rates of both their own and other countries' salmon. The scientific issue is to disentangle and evaluate the relative contributions of these variables on ocean salmon growth.

Effects on Growth

Accurate predictions of the future effect of climate warming on salmon are difficult. One possible approach is to examine the response of salmon to changes in ocean climate through retrospective analyses. The size of salmon at return to the coast varies substantially between years (Ricker 1995). However, the effects of ocean climate on growth are confounded with time because salmon spend 2 to 4 years at sea before their return, depending upon species and life history type (Healey 1986). When is this variation in size expressed?

Measurements of annual growth rings on sockeye salmon scales archived at the Department of Fisheries and Oceans and the Pacific Salmon Commission suggest that substantial growth variation occurs at all ages (Welch 1994). However, in those stocks we have examined so far, variations in the amount of salmon scale growth achieved in any 1 year by a given fish is uncorrelated with the amount of growth observed at other ages for the same fish (e.g., Figs. 6-7). Thus, there does not appear to be any evidence that consistently faster- or slower-growing fish of a given stock occur, nor that the factors affecting scale growth in different years are correlated--the spectrum for the ocean factors influencing scale growth appears to be white rather than red on short-time scales.

Several general effects on scale growth do appear to be noteworthy, however. First, long-term declining trends in scale growth appear to be largely confined to those ages when a given life history type transits the coastal zone on its way offshore or on the return trip to spawn. This would be consistent if it is the coastal zone that is primarily food limited, and the recent increases in salmon abundance have resulted in increased trophic competition while in coastal waters. Supporting this conjecture, long-term trends in scale growth appear to be largely absent for those ages when all growth occurs in offshore regions (M2 (second marine year) growth for age 4.2 and 5.3 sockeye, and M2 and M3 growth for age 5.2 sockeye).

Interannual Changes in Ocean Temperature Fields

As the previous section shows, there are large inter-annual changes in final body size, suggesting that food is limiting at some point in the life history (otherwise salmon should always grow at their maximum growth rates). These variations in growth also raise the possibility of conducting retrospective analyses to statistically identify those oceanographic variables that influence growth.

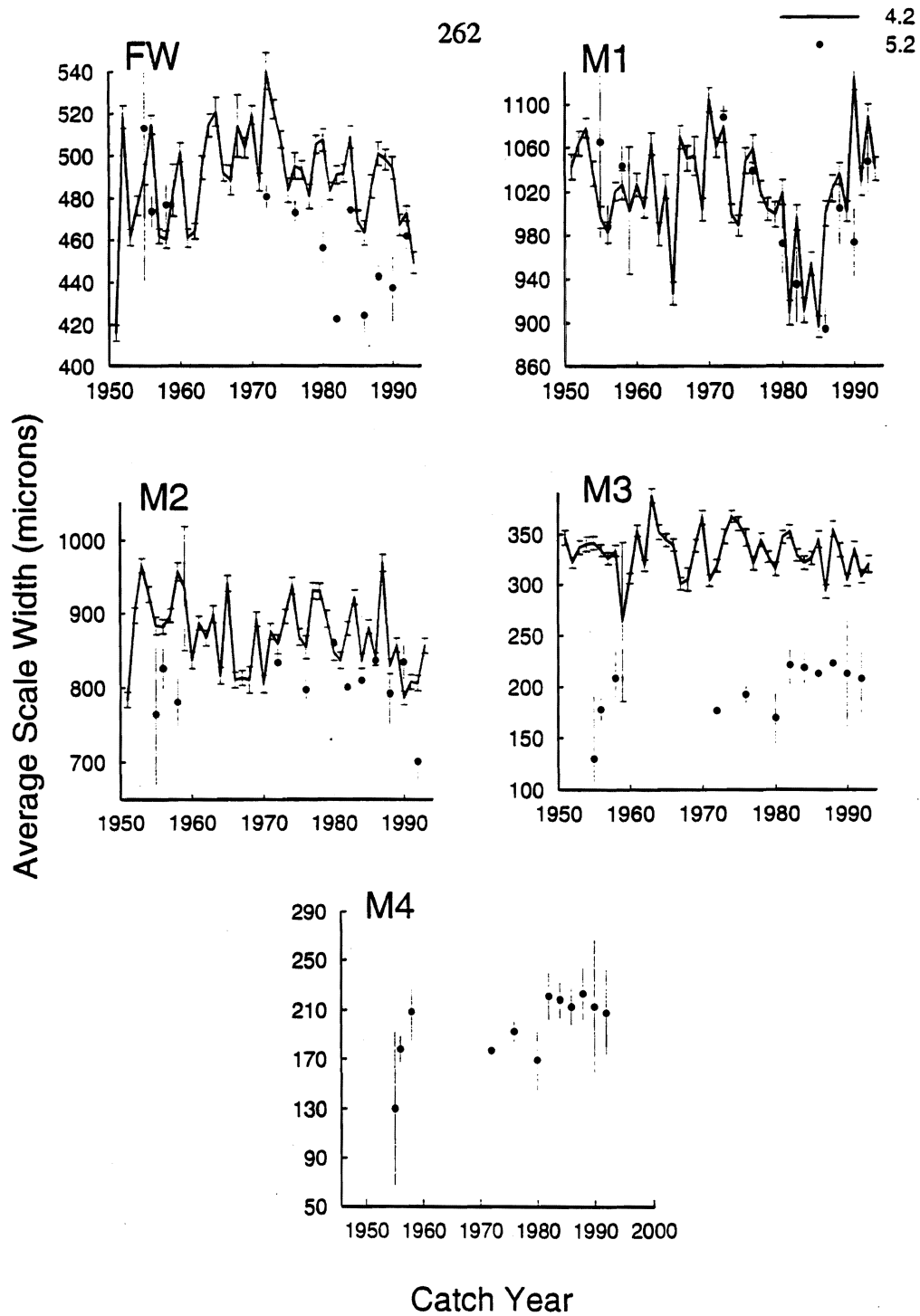

Figure 6. Variation in annual rates of marine growth by year of capture for the Early Stuart stock of Fraser River sockeye salmon. The pattern of variation at different ages is uncorrelated.

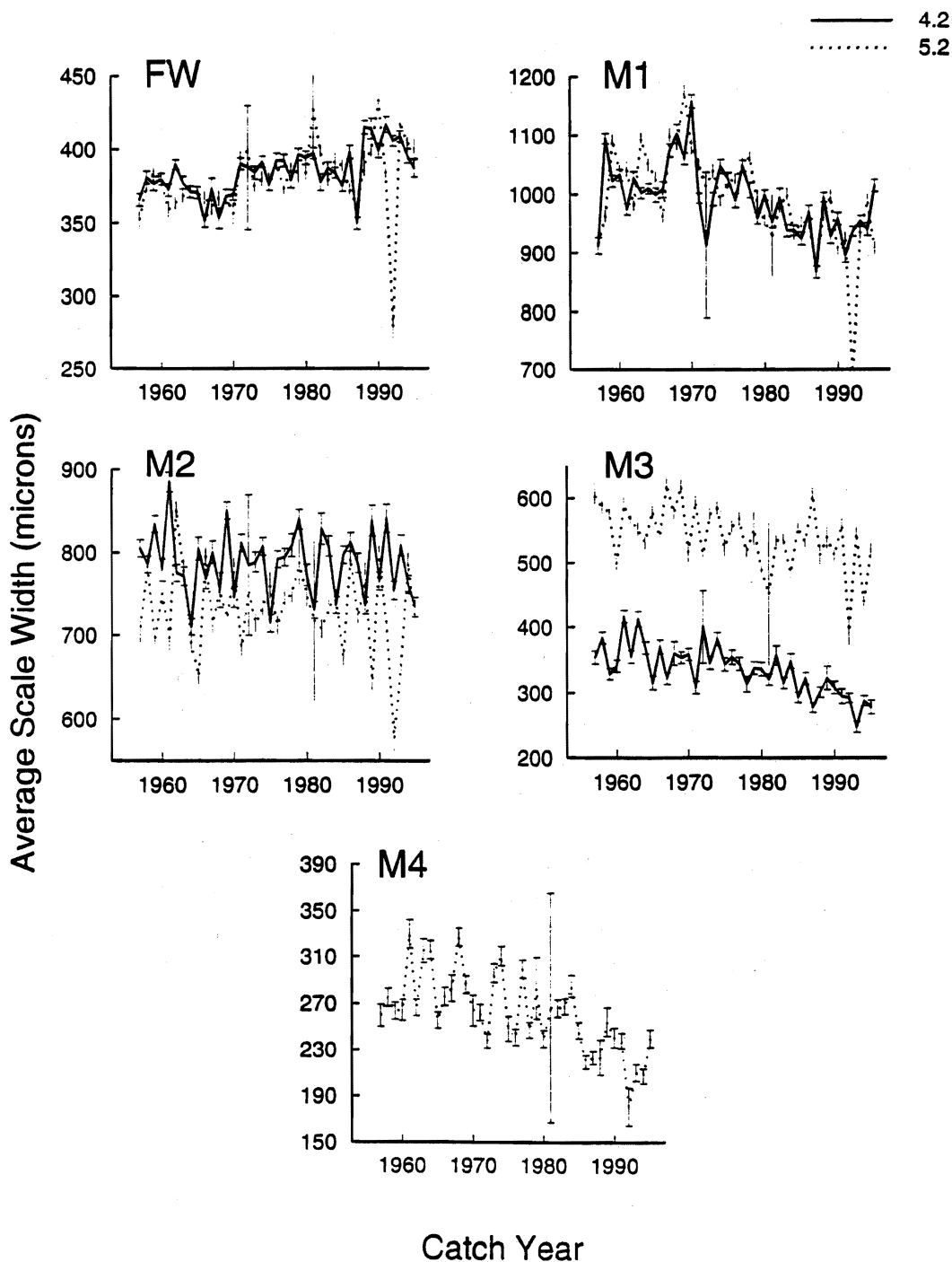

Figure 7. Variation in annual rates of marine growth by year of capture for age 4.2 and 5.2 Skeena River sockeye salmon. Long-term trends toward reduced scale growth are only evident in the first and last years of growth, when sockeye transit the coastal zone. In intermediate years, when sockeye are distributed exclusively offshore, long-term declines in scale growth are not evident although interannual variation in growth does occur.

One such factor is the area of the North Pacific Ocean thermally available to salmon in different years. The ATH for the Gulf of Alaska can be defined as that region of the offshore lying north of some specified isotherm, and east of 160°W. My colleagues at the University of British Columbia (Keith Thomson, Paul LeBlond, and Ian Jardine) and I have begun calculating these areas, using the Comprehensive Ocean-Atmosphere Data Set (COADS) and, in more recent years, the Advanced Very High Resolution Radiometry (AVHRR) data base.

The early results are encouraging as they suggest that since 1948 the winter ATH has varied by a factor of 1.5 or so, while spring and summer ATHs have varied by a maximum of slightly more than 2 (Fig. 8). Although we have not yet begun the analysis of whether fluctuations in ocean area in conjunction with variations in salmon abundance influence salmon growth, this avenue seems to offer a promising approach to assessing the question of whether or not the carrying capacity of the oceans is sufficiently limited to impact the productivity of salmon populations.

Summary

The question of whether the North Pacific Ocean has a carrying capacity sufficiently limited that this fact should be taken into account in our salmon management plans is still a number of years away from being adequately answered. However, the exquisitely sharp response of the ocean distribution of salmon to temperature, presumably related to growth, strongly suggests that natural or artificially induced changes in the growth rates of salmon will have important effects on their productivity and, thus, on the success of our salmon fisheries. The changes in ocean climate that are predicted to accompany climate warming may have massive impacts on the biology of salmon. It is important that we develop a deeper and more quantitative understanding of how growth and survival of salmon in the ocean will change, and to clearly define the link between these biological changes and the sustainable productivity of the fisheries that depend on them.

Citations

- Beitinger, T. L., and L. C. Fitzpatrick. 1979. Physiological and ecological correlates of preferred temperature in fish. *Am. Zool.* 19:319-329.
- Boer, G. J., N. A. McFarlane, and M. Lazare. 1992. Greenhouse gas-induced climate change simulated with the Canadian Climate Centre's second-generation general circulation model. *J. Climate* 5:1045-1077.
- Brett, J. R. 1956. Some principles in the thermal requirements of fishes. *Quart. Rev. Biol.* 32(2):75-87.

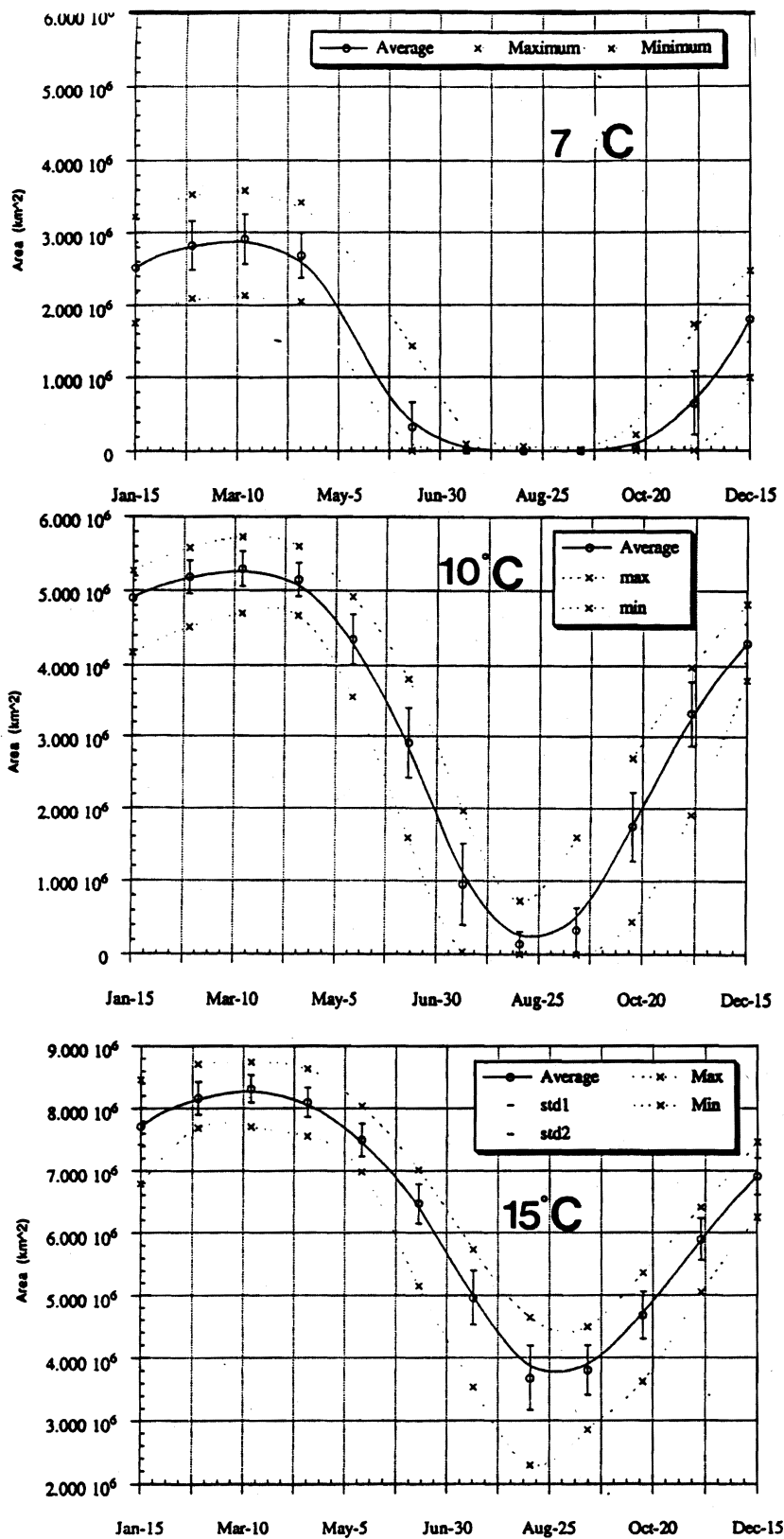

Figure 8. Variation in the amount of available thermal habitat (ATH), defined as the area of the Gulf of Alaska north of the a) 7°C, b) 10.5°C, and c) 15°C isotherms, east of 160°W, and excluding the area of the coastal zone. Large variations between years in the amount of thermal habitat occurred, as evidenced by the difference between the minimum and maximum areas estimated since 1948. The seasonal cycle of thermal habitat can be reconstructed by taking the ATH for 7°C isotherm in winter, the 10.5°C isotherm in spring, and the 15°C isotherm in summer.

- Brett, J. R. 1971. Energetic responses of salmon to temperature: A study of some thermal relations in the physiology and freshwater ecology of sockeye salmon (*Oncorhynchus nerka*). *Am. Zool.* 11:99-113.
- Brett, J. R., J. E. Shelbourn, and C. T. Shoop. 1969. Growth rate and body composition of fingerling sockeye salmon, *Oncorhynchus nerka*, in relation to temperature and ration size. *J. Fish. Res. Board Can.* 26:2363-2394.
- Forbes, L. S., and R. M. Peterman. 1994. Simple size-structured models of recruitment and harvest in Pacific salmon (*Oncorhynchus* spp.). *Can. J. Fish. Aquat. Sci.* 51:603-616.
- Friedland, K. D., D. G. Reddin, and J. F. Kocik. 1993. Marine survival of North American and European Atlantic salmon: Effects of growth and environment. *ICES J. Mar. Sci.* 50:481-492.
- Healey, M. C. 1982. Multispecies, multistock aspects of Pacific salmon management. *In* M. C. Mercer (editor), *Multispecies approaches to fisheries management advice*. *Can. Spec. Publ. Fish. Aquat. Sci.* 59:119-126.
- Healey, M. C. 1986. Optimum size and age at maturity in Pacific salmon and effects of size-selective fisheries. *In* D. J. Meerburg (editor), *Salmonid age at maturity*. *Can. Spec. Publ. Fish. Aquat. Sci.* 89:39-52.
- Levy, D. A. 1992. Potential impacts of global warming on salmon production in the Fraser River watershed. *Can. Tech. Rep. Fish. Aquat. Sci.* 1889:1-108.
- McFarlane, N. A., G. J. Boer, J. P. Blanchet, and M. Lazare. 1992. The Canadian Climate Centre second-generation general circulation model and its equilibrium climate. *J. Climate* 5:1013-1044.
- Ricker, W. E. 1995. Trends in the average size of Pacific salmon in Canadian catches. *Can. Spec. Publ. Fish. Aquat. Sci.* 121:593-602.
- Welch, D. W. 1994. Variation in marine growth rates of British Columbia pink and sockeye salmon stocks. *Proceedings of the Annual Meeting of the North Pacific Anadromous Fish Commission, Vladivostok, Russia, October 1994*. NPAFC Document 94:1-30.
- Welch, D. W., A. I. Chigirinsky, and Y. Ishida. 1995. Upper thermal limits on the oceanic distribution of Pacific salmon (*Oncorhynchus* spp.) in the spring. *Can. J. Fish. Aquat. Sci.* 52:489-503.

Welch, D. W., Y. Ishida, and K. Nagasawa. In prep. Thermal limits and ocean migrations of Pacific salmon: Long-term consequences of global warming. (Available from Ocean Sciences and Productivity Division, Department of Fisheries and Oceans, Pacific Biological Station, Nanaimo, BC, Canada V9R 5K6.)



REPORT OF WORKING GROUP ON PARTITIONING SURVIVAL

Chair: Mike Bradford
Rapporteur: Colin Levings

**Rationale for Attempting to Partition Survival Between
Freshwater, Estuarine, and Marine Habitats**

The group concluded that a major reason for obtaining data on survival rates in the three major habitats was to avoid "ratcheting to extinction." While there appears to be evidence for decadal-scale changes in ocean conditions and overall levels of salmon production, it is not clear what role low frequency changes in climate have on freshwater environments. Further, freshwater productivity may be affected by habitat disruption. Salmon managers need information on freshwater survival to ensure that river habitats maintain the capacity to rebuild stocks. Salmon populations are buffeted by changes in marine habitat and fishing while at sea, and recovery from these stresses would be more difficult if the populations were recovering from low freshwater survival as well. For example, if survival was low in both freshwater and marine habitats simultaneously, it may be difficult to change harvest rates fast enough to maintain a viable population. Alternatively, if salmon were experiencing high survival rates in the sea, compensating for low survival in fresh water, conservation of habitats might be difficult but would be essential for rebuilding efforts. It is therefore necessary to track survival in the three major habitats simultaneously.

Research Strategies Suggested

There was some debate about the usefulness of setting up a null hypothesis for the ecological work required, given the difficulties of designing field experiments covering oceans and major landforms such as watersheds and estuaries. The following was suggested as a conceptual null hypothesis: "There is no link between freshwater and ocean survival."

It was agreed that an understanding of the roles of the three major habitat types on salmon recruitment requires analysis of long-term series of demographic data. As a first step it was suggested that there are some existing data sources that have not yet been fully utilized. These include the coastwide coded-wire-tag (CWT) database, and scale archives for sockeye salmon. A first step would be to assemble a meta-database on salmon survival that would make information readily accessible to researchers. The databases established for endangered species could be reviewed to avoid duplication of effort. It was recognized that the database varies with species, sampling protocols, and geography, but it was noted that in spite of these variations some coastwide data sets such as those for CWTs and stock identification seem to be working.

While chinook salmon data for disrupted systems such as the Sacramento and Columbia Rivers are relatively good, information from rivers and estuaries farther north, such as the Fraser and Stikine Rivers, are poor. The northern systems offer an opportunity for reference (or "control") data. The information on sockeye salmon from the northern systems, however, is good, and in fact results from these databases tend to heavily influence our understanding of salmonid ecology in the Northeast Pacific. However, it was recommended that investigators continue to "mine" the sockeye salmon database, including the scale archives of the former International Pacific Salmon Fisheries Commission.

Regarding new initiatives, there was at least partial consensus that progress would be made if research were focused on a few watersheds along the coast of the Northeast Pacific. The emphasis of this work would be to establish long-term monitoring programs that would allow assessment of decadal-scale processes in all environments. Research at present is not focused enough to measure survival simultaneously in marine and freshwater habitats, and there is a desperate need to set up coordinated studies addressing salmon survival relative to hydrology and oceanography. A network of salmonid ecologists, oceanographers, and hydrologists in the region might be established to move this idea along. It might be useful to restart some of the older long-term studies on freshwater survival to speed up the process of understanding changes in fresh water due to climate or habitat change.

Several approaches to determine survival in the three major habitat types were discussed. It was pointed out that measuring survival rates should be viewed as the major goal in a research program. Understanding mechanisms will be very difficult and from a management point of view may be a secondary priority. Existing weirs and counting fences in headwaters could be harnessed to measure survival if additional facilities were built just above the limit of tide in the estuaries. Ocean and estuary survival could then be obtained by subtraction. Survival in the estuary would be more difficult to obtain, but with concerted efforts such as those of Parker (1971), the estimates could be done. The idea of tracking an individual fish throughout its life history in freshwater, estuarine, and ocean habitats was raised as an alternate approach to population ecology. Recent developments in telemetry may enable such investigations.

Other possible projects could focus on habitat or landscape changes in the region, but they should be in association with measures of survival. It was thought that investigating the Pacific Northwest Index (sea surface temperature, rainfall, and thermocline depth) might be extended to other coastal regions. There is also scope for development of other indices in fresh water (e.g., snow pack) and estuaries (e.g., salt wedge penetration). Changes in the condition of landscapes in watersheds and estuarine wetlands through time could be assessed by analyzing historical series of aerial photos.

Barriers to Progress

It was concluded that there was a lack of vision for research concerning partitioning of salmon survival in their major habitats. Terrestrial ecologists have a comprehensive network of monitoring plants and animals and their habitats on land, but there is nothing comparable for salmon in rivers, estuaries, and oceans. In general, funding to determine salmon survival is spotty, unstable, and only available in crises. There is an illusion in the public that current levels of activity are resulting in the accumulation of reliable abundance data that can be used to monitor changes in salmon survival. It was proposed that the involvement of nontraditional groups (National Science Foundation, schools, clubs, etc.) might have utility in maintaining continuity in long-term monitoring programs. The reality and need for these types of programs must be pointed out to politicians at all levels of government, to educators, and to our friends and neighbors at the local level.

Citation

Parker, R. R. 1971. Size selective predation among juvenile salmonid fishes in a British Columbia inlet. *J. Fish. Res. Board Can.* 28:1503-1570.



REPORT OF WORKING GROUP ON ESTUARINE HABITAT
PROBLEMS AND RESEARCH

Chair: Robert Emmett
Rapporteur: Bruce McCain

The estuarine work group felt that many of the research needs identified by the Estuaries and Inlets Working Group during the 1983 meeting are still valid and perhaps even more necessary than a decade ago. In particular, the call for long-term data sets and a consistent research and monitoring program in estuaries in 1983 was not heeded. Participants identified the relation between salmonid mortality and timing and duration of estuarine residence as one of the most important unanswered questions critical to establishing the importance of estuarine areas to the health of salmon populations. The relative lack of knowledge about the importance of estuaries to salmonids became apparent as our group spent a considerable amount of time discussing the need to have a document that describes the value of estuaries to salmonids for managers and nonscientists. If managers and governments are going to put money into estuarine research and monitoring, they need to know how and why estuaries are an important life history stage for Pacific salmon. The role of estuaries in the life history of the various salmonid species and stocks needs to be described. A comprehensive review paper describing the relationship between estuaries and salmonid life histories, similar to that of Simenstad et al. (1982), would be valuable, although much essential information is still unavailable.

To begin our discussion, we revisited the hypotheses identified in 1983 and reviewed where the science has come since that time.

H₁ Mortality in estuaries is size and density dependent.

We still need data on how estuarine/ocean survival varies relative to the size of smolts and the number (densities) of smolts in estuaries. In particular, we need information on how the structure and functions of various habitats in estuaries affects salmonid survival. Information on dependent and independent variables, natural and anthropogenic factors affecting mortalities, and long-term databases are unavailable for any West Coast estuary, with the possible exception of San Francisco Bay.

A research program using salmon from hatcheries and net-pen operations (e.g., Youngs Bay, Columbia River estuary) focused on the effects of different smolt release strategies (timing, size, density) relative to various estuarine habitat parameters (food, temperature, predators, etc.) on percent returning adults would be valuable. Of major interest would be how specific physical and biological factors in estuaries (food, temperature, predators, residence time, etc.) affect salmon mortalities.

H₂ Within-estuary mortality is habitat specific.

Most research related to effects of habitat-specific factors has been conducted in fresh water, although some work has been done in Coos Bay, the Columbia River estuary, and the Campbell River estuary. Nevertheless, these estuarine studies simply identified that estuarine use enhanced survival but did not identify the mechanisms. The primary research issues are the differential uses of various estuarine habitats by juvenile salmonids and the mechanisms and functions of these uses with respect to salmonid mortalities. Research strategies recommended by the 1983 Working Group have not been undertaken.

H₃ Salmonid mortalities in estuaries are dependent upon smolt fitness.

The general feeling of the groups was that relatively more research has been done addressing this issue than H₁ and H₂. A variety of measures of smoltification and physiological status has been developed since 1983. Some physiological parameters in smolts may also be related to critical behavior (migration rates and location, feeding habits) that could affect survival. In addition, exposure of smolts to chemical contaminants in urban estuaries can affect the fitness of certain juvenile salmonid species. A key question was identified: How could fitness and physiological characteristics in hatchery reared and wild smolts affect differential mortalities? The feeling was expressed that hatchery fish are generally less fit than wild fish, and that the presence of hatchery fish in rivers and estuaries could potentially reduce the fitness of co-occurring wild fish. Recent advances in blood chemistry analysis (assays of endocrine growth factors) may assist with differentiating smolts that are growing slowly from those that are growing rapidly, and thus be able to tell us which smolts will survive and which estuaries/rivers are producing better smolts.

H₄ Salmonid mortalities in estuaries are dependent upon the timing and duration of estuarine residence.

This was identified as one of the most important hypotheses we discussed. Several people expressed the opinion that natural and human-induced changes in estuaries can and have influenced the timing and duration of estuarine residence, and that the estuarine experience of smolts can determine ocean survival. For example, changes in regional and coastal ocean climate and associated circulation changes can affect estuarine productivity and availability of salmonid predators, and upwelling and freshwater inflow can affect estuarine primary productivity and food availability. Specific questions related to this hypothesis were: How do various salmonid species and stocks respond to various estuarine pulses in productivity, predators, and competitors? How is the timing and duration of estuarine residence linked to ocean conditions? How do increased salmonid densities influence timing and duration of estuarine residence? This last question relates to the effect of hatchery releases on estuarine use by wild salmonids.

It was the overall consensus of the group that much more information is needed on this topic. Ideally, researchers would gather timing and residence-time data from a range of estuaries, habitats, and salmon species, and from multiple years encompassing climate variability (e.g., regime shifts) and salmonid life history durations.

H₅ Size, density, condition, and time of emigration from estuaries influence coastal and oceanic mortality rates.

This is a difficult hypothesis to test because it is difficult to distinguish between oceanic and estuarine mortalities. Some research has been conducted, is being conducted, or is being proposed to address this question--including the work by Reimers (1973), the studies being conducted in the Skagit River in which smolts are being tracked from the river to salt marshes, and possible future retrospective studies. It was generally felt that scale studies would be valuable for determining the relative growth rates of different salmon stocks within estuaries (some agencies and Native American tribes have extensive scale collections).

Other Hypotheses Proposed by this Working Group

H₆ Hatchery smolts influence mortalities in wild smolts.

Several factors were mentioned which could influence this hypothesis, including competition for food, attraction of predators (e.g., mammals and birds) by major pulses of hatchery fish, emigration timing, and disease transmission.

H₇ Physical/chemical conditions in estuaries can affect the growth and survival of migratory juvenile salmonids.

Several factors were mentioned which could influence this hypothesis, including temperature, salinity, dissolved oxygen, flow, turbidity, and chemical contamination.

H₈ Predators in estuaries can control the survival of juvenile and adult salmonids.

Several factors were mentioned which could influence this hypothesis, including the abundance and distribution of certain species of marine mammals, birds, and fish, and the activities of commercial and recreational human fishers.

H₉ The presence of exotic species can affect the survival of juvenile and adult salmonids.

Because of limited time, no defining factors were discussed by the group. However, comparing the estuarine use and survival of salmonids in estuaries that include many exotic species with an estuary of few exotic species may not be easy to do because nearly all estuaries now have exotic species. Exotic species introductions into West Coast estuaries continues to be a problem, and we may be conducting this experiment without documentation.

H₁₀ No single estuarine-associated factor is the dominant determinant of the optimum health and survival of salmonids.

The large and varied life history diversity and strategies of salmonids suggest that no single physical or biological factor may consistently determine overall salmonid survival. Through hatchery manipulation and reductions of wild populations, overall salmonid life history diversities have been greatly reduced. Because of this reduction, so called "environmental bottlenecks" may now have severe consequences.

Discussion of Research Needs

There was a consensus that multidisciplinary, multiyear research programs are needed to assess the extent and mechanisms of juvenile salmonid mortalities in estuaries and the nearshore ocean. In particular, one major question needs to be addressed: Are physical, chemical, and biological factors in estuaries useful predictors of the health and survival of some life history stages of some salmonids species? Examples of suggested investigations included:

- Determine the requirements of various life history stages of salmonid species for various biological, chemical, and physical factors available in estuaries.
- Assess the influence of diseases on mortalities of juvenile salmonids by evaluating relationships between disease prevalence in salmonids in estuaries and percent returning adults to the respective rivers and hatcheries.
- Evaluate relationships between growth rates in juvenile salmonids (e.g., determined from measurements of daily growth rings in otoliths or from scales) and percent returning adults.
- Assess relationships among the timing of juvenile migration, the duration of estuarine residency, and the health and survival of these juveniles.

These estuary studies should be performed in concert with observations of nearshore and ocean conditions and with survival studies.

There was also a general feeling that the process of developing research strategies had to address funding sources. Examples of important research guidelines included an explanation of how the results would help guide management decisions about improvements to estuaries to protect and enhance salmon stocks, address the biggest gaps in our knowledge, and demonstrate the importance of estuaries to the recovery of depressed salmon stocks.

A number of participants expressed the feeling that estuaries are critical to the health and survival of certain life history stages of certain salmonid species, but more information is needed about the mechanisms. An idea was formulated to develop research programs in small coastal estuaries, such as the estuaries of the Salmon, Alsea, Yaquina, and Siletz Rivers in Oregon, to address some of these mechanistic questions.

Overview of Estuarine Habitat Working Group Session

Estuaries are valuable to salmonids, and research is needed to:

1. Conduct regional comparisons of watersheds and estuary linkage, and
2. Determine how estuaries and their respective salmonid stocks have been modified, and evaluate the repercussions of these modifications.

The mechanisms for various factors in estuaries affecting the health and survival of salmonids need to be determined. Only by conducting multiyear, multidisciplinary research, in a variety of estuaries, can the common estuarine mechanisms controlling salmonid estuarine/ocean survival be established.

Citations

Reimers, P. E. 1973. The length of residence of juvenile fall chinook salmon in Sixes River, Oregon. Oregon Fish Comm. Res. Rep. 4(2):3-42.

Simenstad, C. A., K. L. Fresh, and E. O. Salo. 1982. The role of Puget Sound and Washington coastal estuaries in the life history of Pacific salmon: an unappreciated function. *In* V. S. Kennedy (editor), Estuarine comparisons, p. 343-364. Academic Press, New York.

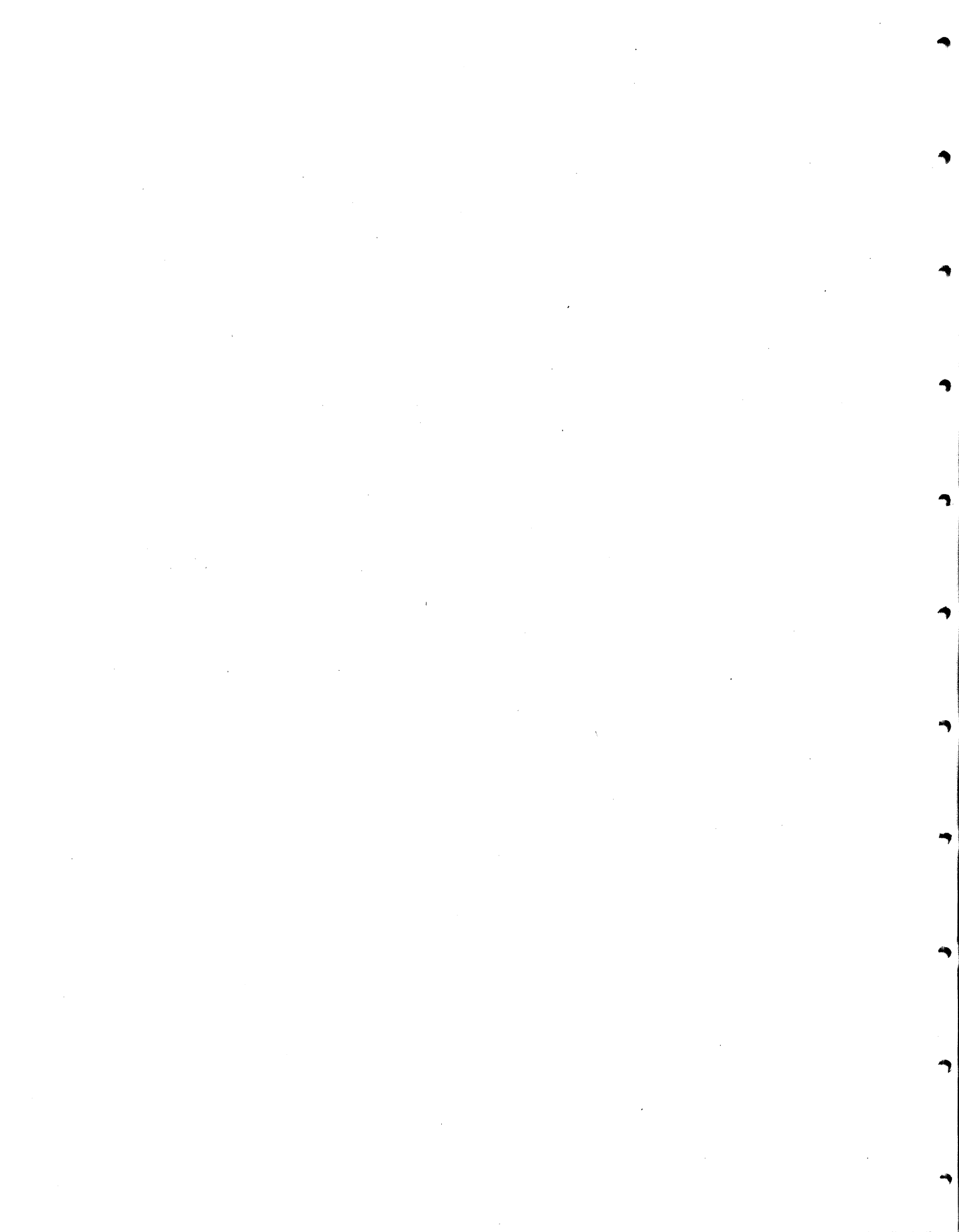

REPORT OF WORKING GROUP ON NEARSHORE HABITATS

Chair: W. T. Peterson
Rapporteur: R. D. Brodeur

Statement of Overall Goal

Understanding the causes of salmon declines is critical to understanding long-term trends in salmon production, and to developing effective tools for forecasting future changes.

Goal of the Nearshore Group

Understanding factors that control mortality and growth of juvenile salmonids during their first few months at sea is also critical.

Long-Term Trends in Salmon Production and Climate

1. The proportion of outmigrating Oregon Production Index hatchery coho salmon smolts that return to spawn has declined from 5-10% (in 1960s and 1970s) to less than 1% in the 1980s to present.
2. The long-term trend appears to be related to the regime-shift which took place in 1976-77; high survival was observed before the regime shift in the late 1970s and early 1980s, low survival thereafter.
3. The proportion of coho salmon surviving to return to spawn was correlated with the Bakun upwelling index during the 1960s and 1970s; since the early 1980s until present, there has been no correlation with the upwelling index.

General Research Needs

- Need to understand what the Bakun upwelling index is telling us about "ocean conditions."
- Need to understand if wild and hatchery reared salmon have different growth and survival rates.
- Compare growth and survival of a few index stocks of salmon in different coastal oceanographic regions (e.g., compare juvenile salmonids that reside primarily south of

Cape Blanco vs. north of Cape Blanco). Also, compare adjacent stocks (e.g., Siletz, Yaquina, Alsea) within a region to discriminate common ocean effects from natural stream habitat effects.

- Available evidence suggests that, for Oregon Production Index (OPI) coho salmon, much of the marine mortality occurs during the first few weeks at sea, when the juveniles are resident nearshore and in the continental shelf waters.

General Hypotheses

- H₁ Mortality is due to predation by birds, mammals, and piscivorous fishes such as mackerel and Pacific hake; recent increases in predation rate may be due to increased abundances of predators.
- H₂ Mortality rates are higher during periods of poor ocean conditions (i.e., if salmon which are just entering the sea encounter poor feeding conditions, their growth rates may be low, their condition may be poor, and thus their small size and weakened conditions may make them more susceptible to predation).
- H₃ Wild fish have higher survival rates than hatchery fish because they have higher growth rates and are better at avoiding predators.

Most Compelling Opportunity

Beginning in 1997, all coho salmon produced in Oregon hatcheries will be marked (adipose fin clipped). This gives us the opportunity to compare hatchery and wild fish in estuaries and in the ocean with respect to a differential in the timing of migration to sea, dispersal at sea, distribution and abundance, food habits, growth, and survival. In the write-up which follows, the reader should keep in mind the opportunities provided by such a unique comparison.

Description of possible research activities

1. Calibration of Bakun upwelling index--better definition of what is meant by "good" vs. "poor" ocean conditions

Since the climate shift in 1976-77, the Bakun upwelling index has not been a very robust predictor of salmon survival. Although correlations between coho salmon survival and upwelling were good for data from the pre-1976 cool regime, there is no correlation for data

during the present warm regime. This may be explained simply by the fact that we have not had a summer of high upwelling since 1976, so all of the data since the late 1970s fall within the lower quadrant (low upwelling and low survival). It may be that the signal-to-noise ratio is now too low to permit a useful correlation. The conclusion is that it is unclear how to interpret any correlation between salmon survival and upwelling. How does upwelling affect salmon survival? Directly by providing a large cool-water habitat, or by setting up favorable circulation patterns that are vital to salmon survival in some way? Indirectly by fueling biological productivity, thus enhancing levels of prey biomass? Is there a critical interaction between winds, circulation, upwelling and productivity in April/May when fish first go to sea? Are such interactions more important later in the upwelling season during the period of strong upwelling and maximum zooplankton abundance in July/August? In an interannual context, how is the Bakun upwelling index a measure of "good" vs. "poor" ocean conditions? Certainly a summer during which winds blew from the north every day would produce very different biological conditions in the coastal waters off Oregon than a "normal" upwelling season characterized by pulses in wind speed and direction.

Coastal upwelling off Oregon is characterized by active upwelling events having northerly winds blowing for 4-10 days duration that are interrupted by periods of calm or southerly winds. Seasonally integrated biological productivity in shelf waters is almost certainly higher under the condition of pulsed rather than continuous upwelling. What is the optimal set of pulsed events (e.g., 7 days upwelling, 4 days relaxed; 7 days upwelling, 7 days relaxed . . .)?

2. Relationships between salmon distribution, abundance, growth, and survival and the "complexity" of coastal waters

The "complexity" of the environment may be an important feature of continental shelf waters that is critical to salmon survival. For example, when studying a map of sea surface temperature taken during strong upwelling, one observes mesoscale variability in the form of fronts with complex shapes (sinuous ribbons rather than straight lines) and numerous small eddies. The productive habitat is larger in general, with upwelled water found all over the continental shelf and farther offshore. This complexity creates an enlarged habitat volume for juvenile salmon with many patches where salmon may forage. During weak upwelling, habitat is reduced in volume, there is little complexity (i.e., physical features may only parallel the coast) and juvenile salmon may become concentrated into a smaller volume nearshore. Since their predators may also be forced into a smaller volume, salmon may become more susceptible to predators.

Habitat complexity is influenced by basin-scale weather and climate patterns and freshwater discharge. Large-scale climate variations affect seasonal upwelling; duration, intensity, and timing of freshwater discharge from the Columbia River contribute to habitat complexity by influencing fronts.

The need to understand the linkages among scales was identified by several participants. In what ways do local upwelling dynamics respond to large-scale basinwide forcing? This is related to the problem of understanding what the upwelling index is telling us--if the upwelling index is a function of large-scale dynamics, whereas the biological response in nearshore waters is due to local winds, then the upwelling index may be providing little useful information about local production.

3. Comparison of growth and survival of hatchery and wild coho

Beginning in 1997, all Oregon hatchery coho salmon will be marked (adipose fin clipped). This gives us the opportunity to compare hatchery and wild fish in estuaries and in the ocean with respect to studies of timing of migration to sea, distribution and abundance, food habits, growth, and survival. This also makes possible another experiment in which growth and survival of hatchery fish from different river systems can be compared. This would be made possible if the otoliths of hatchery fish were thermally marked by increasing/decreasing the temperature of hatchery pond waters for a day or two, so that a "check" appears on the otolith. Repeated three to four times over a 2-week period, four to five checks will be laid down. By varying the interval between checks among hatcheries, all the fish from a hatchery would carry the same code. One could select a few river systems, mark the fish, and compare growth/survival of fish from hatcheries from large vs. small rivers, northern vs. southern rivers, and rivers with and without estuaries, for example.

4. Carrying capacity of the nearshore zone

When planning a comparative study of survival and growth, a key question is where do salmon reside during their first few days at sea? If they remain in a zone very near to shore, then a very different set of variables will operate to modulate growth and survival as opposed to fish that immediately disperse over the entire continental shelf environment. Do salmon seek out specific oceanographic environments (just outside the surf zone, within cool upwelled water nearshore, mesoscale eddies or fronts, offshore in waters bordering the Columbia River plume)? Do wild salmonids occupy different habitats than hatchery salmonids?

5. Factors related to mortality

Who are the key predators? Are mortality rates highest during the first few days at sea or are rates low but constant during the first few months? Studies of predation are straightforward but will require a large effort in order to give a definite answer to the question of who are the key predators. To obtain information on predator distribution, biomass, and feeding rates, an ambitious field program will be needed that involves acoustic as well as trawl surveys of potential piscivorous predators. The surveys should be conducted weekly

during April/May to cover the first few weeks at sea, as well as at least a twice-monthly frequency during the summer months. When planning studies of predation by fishes on juvenile salmonids, one must keep in mind that salmonids are probably rare entities within the prey field of a Pacific hake or mackerel, for example. But, with sufficiently large sample sizes for predators, a predation hypothesis can be evaluated. The best places to conduct such studies may be where juvenile salmonids are most highly concentrated, such as near the mouths of larger rivers like the Columbia or near hatcheries that are near salt water such as in Barkeley Sound (Vancouver Island--see abstract by Hargreaves in this volume) or in Puget Sound. In addition, bird and mammal predator surveys may be required.

6. Need to establish long-term study of a few index stocks

Given the changes in salmon survival that are associated with long-term climate variations, we need an assessment of how key oceanographic and biological variables may affect selected index stocks. The group agreed that new research should focus on comparing and contrasting responses of salmonids from a few different river systems. Growth and survival may have some stream dependency, thus there is the potential that interesting comparisons could be made following a research plan outlined above in the section on comparisons of stocks. Along these lines, discussion became centered upon another useful comparison of growth and survival, that of resident stocks vs. ocean migratory stocks to sort out mechanisms and scales of variability. Specific examples included coho salmon stocks in Puget Sound, some of which are resident and others of which migrate into the Pacific Ocean, returning to Puget Sound to spawn.

7. Need for coordinated efforts was stressed

The group discussed the need for a more coordinated approach to studies of relationships between upwelling, biological productivity, ecosystem structure, trophodynamic connection, and early life history of salmonids. The various comparisons outlined above would be best if carried out as a long-term study in a few index streams.

Along these lines, it was recognized that we need to develop a strategy for funding long-term studies of salmon ecology, and that the best approach may be to form an international steering committee made of representatives from the western states (including Alaska) and Canada at a minimum.

General Approaches

Apart from the specific process studies outlined above, the group discussed the need for modeling studies, retrospective analyses of existing data sets, monitoring, and development

and application of new technologies. Such work should precede process studies because these activities would provide a richer context for hypothesis-based field process experiments.

1. Modeling studies

Coupled physical-biological models are ideal tools to apply toward the problem of understanding how the Bakun upwelling index is related to local production and how the upwelling index is related to large-scale forcing. Ideally, the physical model should be a 3-D model capable of resolving mesoscale features such as eddies, jets, and riverine plumes. The biological component could initially be a simple NPZ model (Nutrient--Phytoplankton--Zooplankton) imbedded in the physical model. The ultimate goal would be to build more complex biological models that include individual-based models of salmon.

The role of predators as consumers of juvenile salmonids can be evaluated initially through modeling. Predator-prey models should be explored that have as input data the abundance of predators, feeding rates of predators, abundance of prey (juvenile salmonids), and abundance of alternative prey. Initially these can be viewed as back-of-the-envelope calculations to determine which predators appear to be the most significant. Once identified, more careful modeling could be initiated to determine whether any top-down regulation occurs in salmon populations.

2. Retrospective studies

Analyses of relations among salmon survival and growth and various time and space scales of meteorological and ocean variables can be done with retrospective comparisons of salmon survival and local forcing, survival vs. large-scale forcing, and salmon growth (using scales) compared to local variables vs. comparisons to basin-scale variables. Large scale/long-term retrospective studies are possible using the COADS and MOODS data sets and by accessing climate data from the NOAA/National Climate Data Center. Oceanic and terrestrial time series are now of sufficient length that it is possible to examine the coupled oceanic-atmospheric-terrestrial system to examine, for example, effects of regime shifts on ocean temperature, coastal weather, changes in rainfall, changes in stream flow, and salmon survival in streams and in the ocean.

3. Monitoring

Too few coastal institutions carry out continuous routine measurements of key oceanographic variables in continental shelf waters. Apart from long time-series of physical parameters such as sea level, sea surface temperature, wind speed/direction, and surface atmospheric pressure measured at buoys and shore stations, there is little information on year-to-year or interdecadal variations in the abundance and distribution in time or space of

plankton, small pelagic fishes, or salmon predators. We must begin to take regular measurements of biological oceanographic variables that relate to ocean productivity, "ocean conditions," or salmon survival. The group agreed that such work needed to be coordinated so that a standard set of measurements were made at common intervals along onshore-offshore transects in key geographic regions. Transects should be located in regions that characterize different oceanographic provinces, such as south of Cape Mendocino, between Mendocino and Cape Blanco, off central Oregon (Newport), near the mouth of the Columbia River, off the central Washington coast, off Vancouver Island, and off central Alaska. Without long-term biological data it will not be possible to truly understand the biological significance of the Bakun upwelling index, nor will it be easy to differentiate between the terms "good ocean conditions" and "poor ocean conditions."

4. Application of new technology

Technology exists for the mass-marking of coho salmon in hatcheries (use of rapid changes in water temperature to produce checks on the otoliths). Such technology is used by the Prince William Sound hatcheries to mark pink salmon. Marking of fish in this manner is very inexpensive. The value is that it permits comparisons of survival and growth of coho salmon as a function of river system.

The group expressed an interest in the development of improved methods of tracking individuals (and stocks) using "smart" archival tags. These tags would record or possibly transmit in real-time the position and depth of an individual fish through its lifetime. RNA/DNA ratios and lipid biomarkers need to be evaluated to develop measures of relative condition of wild and hatchery fish at sea, in relation to food supply or the origin of fish.

Coastal radar systems such as CODAR or OSCAR are sufficiently developed to be applied to long-term study of mesoscale and smaller scale (1-km resolution) variability in upper ocean circulation patterns. With these systems it may be possible to monitor frontal genesis so that the distributional patterns of juvenile salmon at sea can be studied in relation to high-resolution charts of circulation and fronts. If radar data could be supplied in near real-time, sampling at sea could be coordinated with known location of fronts, eddies, and jets.

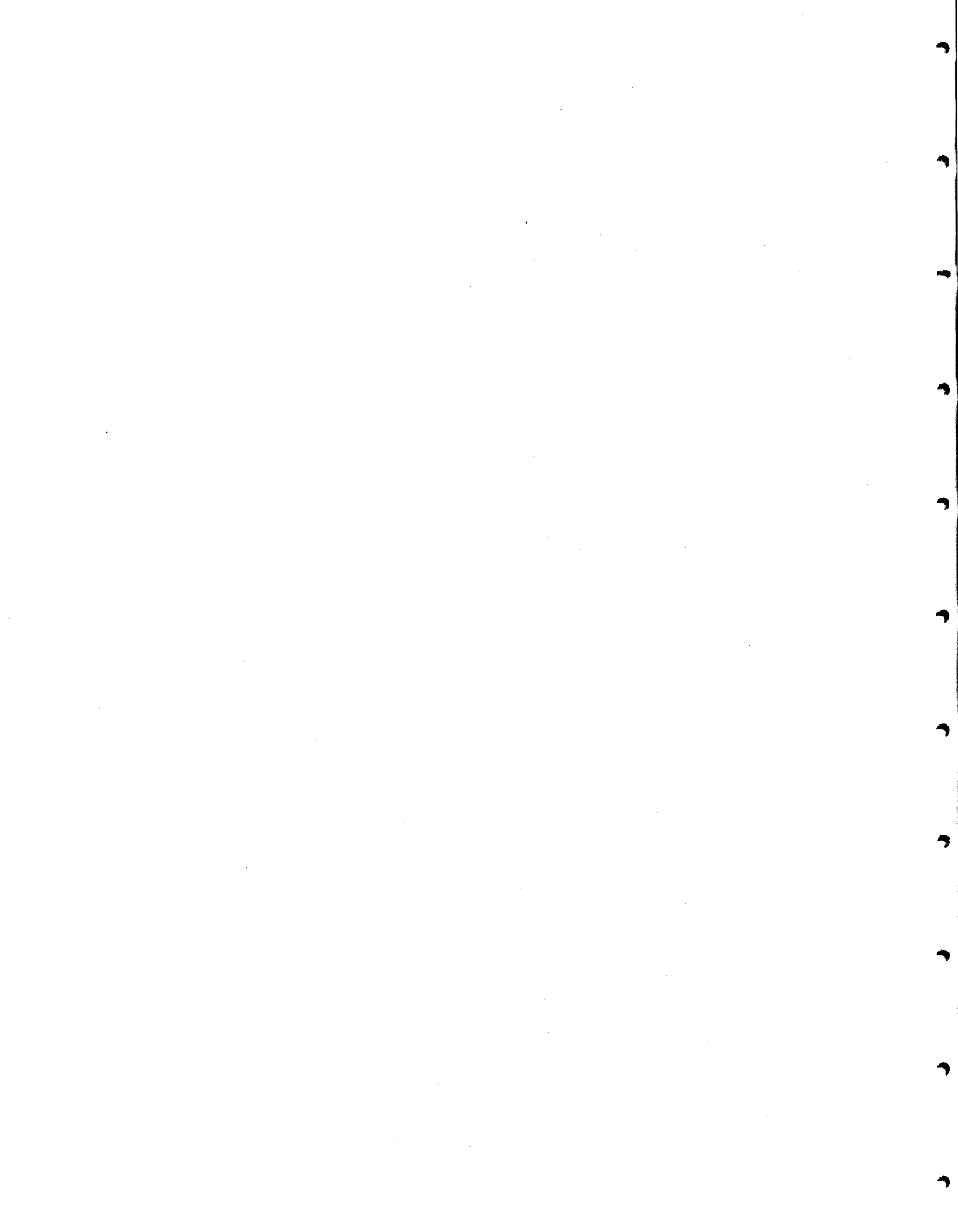

REPORT OF WORKING GROUP ON OFFSHORE HABITAT
PROBLEMS AND RESEARCH

Chair: Katherine Myers
Rapporteur: Steve Ignell

The Offshore Habitat Working Group had an open and informative discussion about problems and research related to oceanic growth and survival of salmon. There was general agreement that considerably more time, effort, and thought are needed to adequately address the objectives outlined in the workshop guidelines. The group identified and discussed some important questions and hypotheses, which are listed below, but emphasized that these results are not prioritized or conclusive. The group decided that its most important task during the meeting would be to present a list of research recommendations to all attendees in the final session prior to adjournment. The group agreed that after the meeting the Chairman would circulate a draft of the results among the participants for review. These reviews are incorporated into the final section of this report.

Highest Priority Questions (order of listing is not significant)

Two associated questions about distribution, migration, and life history patterns are

1. What are the distribution and migration patterns of salmon at sea? How do currents and other physical factors influence distribution and migration patterns? (Possible research strategies involve modeling and tagging, integrated with food studies.)
2. What triggers a change in life history stage (e.g., inshore-offshore, immature-maturing)?

Five associated questions about growth, maturation, fecundity, and survival are

3. What are the relationships between physical forcing and ocean growth and survival?
4. What causes regime-scale changes in survival?
5. What causes long-term changes in growth, maturity, and reproductive potential?
6. What is the role of the ocean in determining fecundity and lipid stores, size-at-age, age-of-maturity, and viability of eggs?
7. How does salmon growth vary across species, space, time, etc., and what are the causes of variability in growth of salmon?

One question about forecasting of adult returns is

8. Can ocean-salmon-catch data be used to forecast adult returns?

Hypotheses

Four associated hypotheses related to salmon distribution and migration patterns are

- H₁ Physical forcing affects the oceanic distribution of salmon.
 H₂ Offshore migration patterns of salmon are genetically determined.
 H₃ Migration paths are selected to optimize growth/production, minimize energetic losses, or, perhaps, minimize the ratio of mortality:growth.
 H₄ Distribution of forage affects oceanic distribution of salmon.

One hypothesis related to the underlying mechanisms of maturation is

- H₅ Maturation in salmon is triggered when some lipid threshold is exceeded.

Three associated hypotheses related to growth and survival are

- H₆ Marine survival (recruitment) is determined by events in the coastal zone.
 H₇ Final size is determined in the oceanic (offshore) zone.
 H₈ There is a positive functional relationship between growth and survival.

One hypothesis related to effects of density on growth, maturation, and reproduction potential is:

- H₉ Growth, age of maturing, fecundity, and reproduction potential are density dependent in the oceanic zone.

Three associated hypotheses related to stock-specific salmon growth are

- H₁₀ Annual stock-specific salmon growth is stationary over time.

H₁₁ Annual stock-specific growth varies interdecadally or shows regime-scale trends.

H₁₂ Growth of Alaska salmonids is inversely related to growth of U.S. West Coast stocks.

Recommendations

1. An integrated, coastwide commitment to a long-term fishery-oceanographic monitoring program in the northeastern Pacific is needed.

The working group envisioned a multidisciplinary scientific research effort, tied to the practical need for better assessment and management of valuable marine resources, that would benefit a variety of species, programs, and agencies. The program would establish a sequence of monitoring lines in the North Pacific (e.g., p hydrologic line off Kodiak Island, Seward line, Papa line, Newport line, and CALCOFI Line 60 off San Francisco) for collection of both surface and subsurface data. Perhaps one vessel would be committed to a basic minimum monitoring program to maintain these lines, but the entire package would include a mix of surface buoys, moorings, ships, and satellites and other remote sensing devices. This multidisciplinary effort requires a long-term commitment, and this commitment must include all aspects of the research, not just the simple physical monitoring. The development of this program and sampling protocols would require extensive coordination with Global Ocean Ecosystem Dynamics Program (GLOBEC), National Oceanic and Atmospheric Administration, Canada's Department of Fisheries and Oceans, and other organizations.

2. Assumptions about ocean distribution and migration patterns must be validated.

There is a need for fundamental biological information on salmon distribution and migration patterns. New techniques (e.g., smart tags) can be used to determine behavioral responses to temperature and other environmental factors and swimming depths, and also as a tool to verify computer models. Stock identification using a variety of methods (e.g., tags, electrophoresis, DNA, scales, and otolith marks) is important to understanding the relationships among distribution, migration patterns, and ocean survival.

3. Interaction among stocks is a key issue that needs to be investigated.
4. Research should focus on weight and energy content of salmon, not just mean lengths or abundance.
5. There should be continued emphasis on the use of scales in studies of ocean growth. A scale workshop coordinated by PICES (an international North Pacific marine science organization) and NPAFC (North Pacific Anadromous Fish Commission) is needed immediately.

6. Better field estimates of feeding and stomach evacuation rates (24-hour sampling) and more comprehensive studies (acoustic and net sampling) of prey species, especially fish and squids, are needed.

There is a need to standardize gear and sampling techniques used in prey studies. Zooplankton data are only a surrogate in areas where salmon are feeding primarily on fish and squid. Most zooplankton gear does not catch small- to medium-sized pelagic squids and similar-sized forage fishes. There may be a need to develop or modify existing gear (e.g., larger mouth opening for trawls) for sampling squid. Neuston collections should be added to the standard array of forage sampling in the areas over the continental shelf and near shore, as smaller outmigrant salmon are surface oriented and feed on items in the neuston. The importance of neuston to salmonids on the high seas still needs investigation.

7. There needs to be a better balance between "top-down" and "bottom-up" approaches in the study of ocean survival.

Research should focus on predators, competitors, and disease organisms. We should be looking at associated communities and the variability in survival due to predation. In particular, more research on the distribution and abundance of predators and predation rates is needed. Because of the lack of data, we may have to start with "back-of-the-envelope" calculations. Research strategies could involve the use of isotope analyses combined with natural chemical tracers to determine food webs. Methods to study disease, competition, and predation need to be designed. All life history stages need to be examined.

8. Research should focus on key stocks (e.g., Bristol Bay sockeye salmon, Prince William Sound pink salmon, Fraser River sockeye salmon, Columbia River chinook salmon, Oregon Production Index coho salmon, and Sacramento River chinook salmon).
9. Working groups to coordinate research efforts should be convened more frequently than every 13 years.
10. There is a need for coordination of acquisition and assimilation of databases, leading, perhaps, to the development of a World Wide Web site to facilitate communication between investigators as well as to serve as a clearinghouse of archived data useful for the study of high-seas salmon.

The group discussed some of the databases critical for this work: 1) inshore salmon catch and escapement data, 2) scale archives, 3) offshore catch and biological data on both salmonids and associated species, and 4) oceanographic data.

Post-Workshop Reviews

Peter Adams: Our principal interest has been in predator-prey studies, and my comments deal with Recommendation 6. We have been monitoring chinook salmon stomach contents off central California since 1980 and prey concentrations since 1983. We have been using a 24-m headrope mid-water trawl to catch forage fish and MIK nets (3-m Issac-Kidd trawls) to catch euphausiids, both with a great deal of success. However, there is no getting around the fundamental patchiness of both salmon feeding and prey distribution, and this requires samples collected over a long time scale. We have found that an understanding of the feeding dynamics and reason for the shifts in prey distributions underlay much of the changes in salmon distribution. Finally, our neuston sampling has not been very useful in explaining these interactions.

Dick Carlson: I have long been concerned with some of our research pursuits that seek answers amidst many factors interacting at once, that is, a flux of conditions that are not separable, and cannot be examined individually or experimented with except as part of a complex. Some research programs make promises to deliver answers to questions that may not have answers--at least none that are consistent and easily explained or understood. Some of the questions and hypotheses we posed would be difficult to test. One area in which I see considerable potential for developing new information is identifying ocean migration patterns of first-year juvenile salmon. This would require sampling over the potential migration routes often and thoroughly enough to locate stock groups of salmon that are found consistently in certain areas or under certain conditions, and accumulating evidence for a pattern (that the researcher defines). Separate cruises to obtain oceanographic and hydrographic information would allow the fish sampling cruises to better focus on that activity. Recommendation 3 (interaction among stocks) also has some potential for resolution by field sampling. Capture at sea of young salmon from stock groups found consistently together would be evidence for interaction, and opens other avenues for investigation. Stock identification techniques would play a major role in this effort.

Steve Ignell: I support the concept of a monitoring program (Recommendation 1), but it needs to be tightly connected to research questions. Rather than arbitrarily set up various monitoring lines, we need to think very carefully about how these lines will provide data to test specific hypotheses. We also need to link the monitoring program to key index stocks. In Recommendation 2, we need to distinguish between stock identification methods that assign stock origin probabilities to a group of fish (GSI and scale analyses) and methods that identify the origin of individual fish (CWT and otolith marks), as they are used to address different research questions. The mass marking (otolith marks) of stocks of salmon in the Gulf of Alaska offers the first good opportunity to study identifiable cohorts of different stocks over a succession of seasons. For each stock, ocean distribution, energy stores, growth, and maturation can be monitored in the context of biophysical variation. To expand upon the importance of energy stores in salmon (see Recommendation 4), several lines of research suggest that an individual's age at maturation is determined by its energy stores,

measured at a particular season of the year. For example, if a salmon's lipid stores in November exceed a "set point" of 10% whole body weight, the salmon will undergo maturation during the succeeding year. Energy stores reflect the nutritional history of a salmon (i.e., how well it fed during the preceding season of growth). Energy stores also reflect the physical environmental (temperature) history, since growth is related to both ration (amount and quality of food) and temperature.

John Karinen: In Question 3, the use of the term "physical forcing" without specification of the range of variables or environmental conditions (e.g., site-specific and regimewide) is inappropriate. Physical factors affecting growth and survival may range from site-specific conditions (tidally modulated boundary effects between water masses of different temperature, salinity, and density) to regimewide interannual, decadal, or less frequent changes in physical conditions. Fish that are successful in finding and following food concentrations along density gradients offshore may survive and grow faster than fish that reside in the center of a water mass where food may not be concentrated. Regimewide changes in physical conditions may change current patterns, temperature distribution, storm tracks, and incidence and persistence of gyres, all of which may affect fish migration routes and perhaps growth and survival. Hypothesis 1 should address site-specific effects rather than regime-wide changes, which have already been shown to affect salmon migration patterns. Do salmon key in on boundary effects and migrate along these food-rich areas? I would change Hypothesis 3 to "Migration paths are selected to maximize survival," as fish are, perhaps, keying on prey abundance and avoiding predators.

Katherine Myers: Much of the difficulty that our work group had in identifying scientific questions and translating these into testable hypotheses arises from a lack of basic understanding of the offshore habitat and life history of Pacific salmon. Our most significant scientific contributions in the near future will likely arise from exploratory and experimental field research on the basic biology and ecology of salmon and associated species in offshore waters. As stated in Recommendation 1, the need for an integrated, coastwide commitment to a fishery-oceanographic monitoring program is closely linked to practical management and natural resource conservation applications. The size and number of adult salmon returning to coastal fisheries each year is largely a mystery because we do not have any information on their oceanic growth and survival. With the end of high-seas driftnet fishing, we have a unique opportunity to discover the natural variation in offshore growth and survival of salmon.

Peter Rand: Many of our hypotheses are mutually exclusive, and will give rise to unique predictions on locations and size (growth) of salmon in space and time. Through modeling exercises, we can codify these hypotheses and make a series of predictions that can be rigorously tested against thoughtful field sampling, ideally employing state-of-the-art sampling technologies, such as acoustics, smart tags, and remote sensing. For example, if we assume that salmon are "navigationally challenged" and that their movements are random, spatial distribution can be projected solely as a consequence of dominant ocean currents. This model can be compared to observed catch distributions. Alternatively, we can assume salmon are

minimizing energy losses or maximizing their energy return on foraging investments, which would lead to additional, unique predictions regarding migration behavior and subsequent distribution that can be further tested. Modeling techniques and field sampling are both important and operate synergistically to help move our science forward. This interplay is particularly appropriate for offshore research because of the difficulty and expense of carrying out exhaustive field efforts and experiments across these broad time and space scales.

Bruce Wing: A definition of "physical forcing" (see Question 3 and Hypothesis 1) is critical to designing observational programs. What physical features do we want the oceanographers to monitor and investigate? Physical features such as thermal fronts, the Sitka Eddy, and river plumes have been shown to affect the return migration routes of several species of salmon, and there is no reason to suspect that such features do not affect outgoing migration routes. We need to identify which features beyond and over the continental shelf are influencing migration routes. To address Hypothesis 3, which relates to evolutionary time scales and not to annual variability, will require a lot more basic knowledge of physical and biological conditions than can be gathered in a short time.



List of Attendees with Photo



Peter Adams
 NMFS
 3150 Paradise Dr.
 Tiburon CA 94920

Brian Allee
 Harza NW Consulting
 2353 NE 130th St. Suite 200
 Bellevue WA 98005

Jim Ames
 Wash. Dept. Fish. Wildl
 600 Capitol Way N
 Olympia WA 98501-1091

Jim Anderson
 Fish. Res. Inst., Rm 376
 Univ. of Washington
 Seattle WA 98195

Jan Auyong Titgen
 Oregon Sea Grant
 Oregon State Univ.
 Corvallis OR 97331

Bob Bailey
 Ocean Program Administrator/LCDC
 800 NE Oregon T. #18
 Portland OR 97232

Jack Barth
 OSU Ocean. and Atmos.
 Burt 410
 Corvallis OR 97331

Hal Batchelder
 U.S. GLOBEC office/Dept. Integ. Biology
 University of California
 Berkeley CA 94720-3140

Richard Beamish
 Dept. Fish. Oceans
 Pacific Biological Station
 Nanaimo B.C. CANADA V9R 5K6

Brian Beckman
 NMFS F/NWC1
 2727 Montlake Blvd
 Seattle WA 98115

Paul Bentley
 NMFS
 P.O. Box 155
 Hammond OR 97121

Jim Bergeron
 Oregon State University Extension Serv
 2050 Marine Drive
 Astoria OR 97103

Nora Berwick
 Power Planning Council
 36785 SW Southwind Dr.
 Hillsboro OR 97123

Gustavo Bisbal
 NW Power Planning Council
 851 SW Sixth Avenue Suite 1100
 Portland OR 97204

Ted Bjornn
 Idaho Coop. Fish Wildl. Res. Unit
 Univ. Idaho
 Moscow ID 83843

George Boehlert
 Pacific Fish. Environ. Group/SWFSC
 1352 Lighthouse Ave.
 Pacific Grove CA 93950

Louis W. Botsford
 Dept. Wildlife and Fish. Biology
 University of California
 Davis CA 95616

Dan Bouillon
 ESSA Consultants Ltd
 300-1765 West 8th Ave
 Vancouver B.C. CANADA V6J 5C6

Burt Bowler
 Idaho Fish Wildlife
 600 S. Walnut St.
 Boise ID 83707

Michael J. Bradford
 Canada Dept. Fish Ocean
 4160 Marine Drive
 West Vancouver B.C. CANADA V7V 1N6

Pat Brandis
 USFWS
 4001 N. Wilson Way
 Stockton CA 95205

Ric Brodeur
 NMFS/AFSC
 7600 Sand Point Way NE
 Seattle WA 98115-0070

Randall Brown
 Calif. Dept. Water Resources
 3251 S Street
 Sacramento CA 95816

Patience Browne
 NMFS/Marine Mammal Lab
 7600 Sand Point Way NE
 Seattle WA 98115

Paul Burns
 US Forest Service, Mapleton Dist.
 P.O. Box 67
 Mapleton OR 97453

Peggy Busby
 NMFS/NWFSC Coastal Zone & Estuarine
 Studies
 2725 Montlake Blvd., East
 Seattle WA 98112-2097

Dick Carlson
 NMFS, AFSC
 7600 Sand Point Way NE
 Seattle WA 98115

Ed Casillas
 NMFS/EC/NWFSC
 2725 Montlake Blvd. East
 Seattle WA 98112-2097

Carl Christianson
 U.S. Army Corps Eng.
 201 N. Third
 Walla Walla WA 00362

Joe Cone
 Oregon Sea Gran
 Oregon State Univ.
 Corvallis OR 97331

R. Ted Cooney
 Institute of Marine Science
 University of Alaska
 Fairbanks AK 99701

Randy Cooper
 283 236 Highway 101
 Port Townsend WA 98368

Daniel M. Daley
 Bonneville Power Admin.
 P.O. Box 3621
 Portland OR 97208

David Damkaer
 21318 195th SE
 Monroe WA 98272

Earl Dawley
 NMFS
 P.O. Box 155
 Hammond OR 97121

Peter Dygert
 NMFS, F/NW02
 7600 Sand Point Way, N.E.
 Seattle WA 98115

Joe Fisher
 Oregon State Univ.
 College of Oceanography
 Corvallis OR 97330

Robert Francis
 Univ. Washington
 Fisheries Research Inst. WH-10
 Seattle WA 98195

James R. Geiselman
 Bonneville Power Adm.
 P.O. Box 3621
 Portland OR 97208

Al Giorgi
 Don Chapman Consultants
 7981 168th Ave NE
 Redmond WA 98052

Hardy Glascock
 660 SW 56th St.
 Corvallis OR 541-754-8835

Robert Hannah
 Oregon Dept. Fish Wildl.
 HMSC 2030 SE Marine Sci. Drive
 Newport OR 97365

Brad Hanson
 NMFS/Marine Mammal Lab
 7600 Sand Point Way NE
 Seattle WA 98115

Jeff Hare
 NMFS/NWFSC
 2725 Montlake Blvd E.
 Seattle WA 98112

Steven R. Hare
 Intern. Pac. Halibut Comm.
 P.O. Box 95009
 Seattle WA 98145-2009

Brent Hargreaves
 Canadian Fish and Oceans
 Pacific Biological Station
 Nanaimo B.C. CANADA V9R 5K6

Jeff Haymes
 Quileute Indian Tribe
 P.O. Box 187
 LaPush WA 98350

Jack Helle
 NMFS, AFSC
 7600 Sand Point Way NE
 Seattle WA

Ray Hilborn
 School of Fisheries
 Univ. of Washington
 Seattle WA 98195

Richard Hinrichsen

Susan Hinton
 NMFS
 P.O. Box 155
 Hammond OR 97121

Lisa Holsinger
 NMFS Protected Species Div.
 777 Sonoma Ave., Rm 325
 Santa Rosa CA 95404

Harriet Huber
 NMFS/Marine Mammal Lab
 7600 Sand Point Way NE
 Seattle WA 98115

Steve Ignell
 NMFS, AFSC
 11305 Glacier Highway
 Juneau AK 99801

Robert Iwamoto
 NMFS/NWFSC/CZES
 2727 Montlake Blvd
 Seattle WA 98115

Herb Jaenicke
 NMFS/AFSC
 7600 Sand Point Way NE
 Seattle WA 98115

Gary, A Johnson
 U.S. Army Corps Eng.
 P.O. Box 2946
 Portland OR 97208-2946

Steve Johnson
 Oregon Dept. Fish Wildl.
 2030 S. Marine Science Drive
 Newport OR 97365

John Karinen
 NMFS, AFSC
 7600 Sand Point Way NE
 Seattle WA 98115

Pat Kight
 Oregon Sea Grant
 Oregon State Univ.
 Corvallis OR 97331

Robert Kope
 NMFS/CZES/NWFSC
 2727 Montlake Blvd
 Seattle WA 98115

Sharon Kramer
 Metro. Water Dist. So. California
 112a L. Street, Suite 900
 Sacramento CA 95814

Ed Lamotte
 USFW

Kathy Larson
 U.S. Fish. Wildlife
 2600 SE 98TH AVE, SUITE 100
 Portland OR 97266

Kim Larson
 U.S. Army Corps of Engineers/Portland
 District
 P.O. Box 2946
 Portland OR 97208-2946

Peter Lawson
 Oregon Dept. Fish Wildlife
 2040 SE Marine Science Drive
 Newport OR 97365

Colin, D Levings
 Dept. Fish and Oceans
 4160 Marine Drive
 West Vancouver B.C. CANADA V7V 1N6

Lisa Lierheimer
 NMFS/NWFSC Seattle, WA
 2727 Montlake Blvd
 Seattle WA 98115

Bruce Lovelin
 Columbia River Alliance
 825 Multohomah, Suite 956
 Portland OR 97232

Bruce MacFarlane
 NMFS, SWFSC, Tiburon Laboratory
 3150 Paradise Dr.
 Tiburon CA 94920

Conrad V. W. Mahnken
 CZES/NMFS
 2715 Montlake Boulevard East
 Seattle WA 98112

William C. Masle
 Bonneville Power Admin.
 P.O. Box 3621
 Portland OR 97208

George McCabe
 NMFS/NWFSC
 P.O. Box 155
 Hammond OR 97121

Bruce McCain
 National Marine Fisheries Service
 2030 SE Marine Science Drive
 Newport OR 97365

Monte L. McClendon
 Bureau of Recl.
 1150 N Curtis Road
 Boise ID 83706-1234

Chip McConnaha
 NW Power Planning Council
 851 SW Sixth Avenue Suite 1100
 Portland OR 97204

Ronald R. McKown
 US Bureau Reclamation
 1503 NE 78th St, Suite 15
 Vancouver WA 98665-9667

Bruce McLeod
 USFW

Greg McMurray
 Oregon DEQ
 811 SW Sixth Ave.
 Portland OR 97204

William McNeil
 1066 Westfarthing NW
 Salem OR 07304

David Miller
 NMFS/NWFSC
 P.O. Box 155
 Hammond OR 97121

Gregory Miller
 NMFS Office Protected Resources
 1315 EastWest Highway
 Silver Spring MD 20910

Chris Moffitt
 Idaho Coop. Fish Wildl. Res. Unit
 Univ. Idaho
 Moscow ID 83843

William D. Muir
 NMFS
 Star Route
 Cook WA 98605

Jim Murphy
 University of Alaska
 Fairbanks AK 99701

Ms. Kate Myers
 Fish. Res. Inst., Box 357980
 Univ. Washington
 Seattle WA 98195-7980

Kazuya Nagaszwa
 National Res. Inst. Far Seas Fisheries
 5-7-1 Orido, Shimizu-Shi
 Shizuoka-ken JAPAN 424

Marta Nammack
 NMFS Office Protected Resources
 1315 EastWest Highway
 Silver Spring MD 20910

Willa Nehlsen
 Pacific Rivers Council
 921 SW Morrison, Rm 531
 Portland OR 97205

David Nelson
 NMFS/ETSD
 525 NE Oregon St -Suite 500
 Portland OR 97232-2737

Tom Nicholson
 Oregon Dept. Fish Wildl.
 850 SW 15 Street
 Corvallis OR 97333

Jim Norris
 P.O. Box 816
 Port Townsend WA 98365

Joe Orsi
 NMFS, AFSC
 7600 Sand Point Way NE
 Seattle WA 98115

John R Palensky
 Bonneville Power Admin.
 P.O. Box 3621 - E.
 Portland OR 97208-3621

John F. Palmisano
 1990 NW 156TH AVE.
 Beaverton OR 97006

Richard Parrish
 SWFSC, Pacific Fish. Envir. Group
 1352 Lighthouse Ave.
 Pacific Grove CA 93950-2097

Mike Parsley
 NBS/Columbia River Field Station
 Star Route
 Cook WA 98605

Charlie Paulsen
 Paulsen Environmental Research
 10175 SW Barbur Blvd., Suite 302B
 Portland OR 97219

William Percy
 Oregon State University
 College of Oceanography
 Corvallis OR 97330

Randall, M. Peterman
 School of Res. Environmental Management
 Simon Fraser University
 Burnaby B.C. CANADA V5A 1S6

Jim Petersen
 NBS/Columbia River Field Station
 Star Route
 Cook WA 98605

William Peterson
 National Marine Fisheries Service/HMS
 2030 SE Marine Science Drive
 Newport OR 97365

Chris Pinney
 COE-Walla Walla
 201 N. Third
 Walla Walla WA 99362

Thomas Poe
 NBS/Columbia River Field Station
 Star Route
 Cook WA 98605

Stanley Ponce
 U.S. Bureau of Reclamations
 D-6700, P.O. Box 25007
 Denver CO 80205

Mark Powell
 Columbia River Research

Richard Prange
 Bureau of Recl.
 1150 N Curtis Road
 Boise ID 83706-1234

Peter Rand
 Fisheries Centre, UBC
 2204 Main Mall, Hut B-8,
 Vancouver B.C. CANADA V6T 1Z4

Kelly Redmond
Western Region Climate Center
P.O. Box 60220
Reno NV 89506-0220

Reg Reisenbichler
NBS-NW Biological Science Ctr.
6505 NE 65 St.
Seattle WA 98115

James Ruff
Northwest Power Planning Council
851 SW 6th Avenue - Suite 1100
Portland OR 97204

Alan Ruger
BPA / EW1
P.O. Box 3621
Portland OR 97208-3621

Robert Schabetsburger

Mike Schiewe
NMFS/NWFSC Coastal Zone & Estuari
Studies
2725 Montlake Blvd., East
Seattle WA 98112-2097

Franklin Schwing
SWFSC, Pacific Fish. Envir. Group
1352 Lighthouse Ave.
Pacific Grove CA 93950-2097

James G. Seelye
NBS/Columbia River Field Station
Star Route
Cook WA 98605

Frank Shipley
National Biological Service
Bldg. 204 Naval Station Puget Sound
Seattle WA 98115-5007

Charles Simenstad
Wetlands Ecosystem Team, WH-10
University of Washington
Seattle WA 98195

Lance Smith
NMFS/ETSD
525 NE Oregon St -Suite 500
Portland OR 97232-2737

Susan Sogard
NMFS Hatfield Marine Science Center
2030 S. Marine Science Drive
Newport OR 97365

John Stein
NMFS/EC/NWFSC
2725 Montlake Blvd. East
Seattle WA 98112-2097

Steve Stone
NMFS/ETSD
525 NE Oregon St -Suite 500
Portland OR 97232-2737

Ted Strub
Oregon State University
Dept. of Oceanography and Atmos. Sci
Corvallis OR 97330

Chris Toole
NMFS/ETSD
525 NE Oregon St.
Portland OR 97232-2737

Robert J. Trumble
Internat. Pacific. Halibut Commission
P.O. Box 95009
Seattle WA 95009

Rudd Turner
U.S. Army Corps of Eng./ N Pac. Div.
P.O. Box 2870
Portland OR 97208

Bill Tweit
Wash. Dept. Fish Wildl.
600 Capitol Way N. MS-43135
Olympia WA 98501-1091

Jim Uehara
Wash. Dept. Fish. Wildl.
600 Capitol Way N
Olympia WA 98501-1091

Usha Varanasi
NMFS/Northwest Fish. Sci. Center
2725 Montlake Blvd. East
Seattle WA 98112

Chuck Voss
Salmonid Foundation
P.O. Q
Woodland WA 98674

Tom Wainwright
NMFS/CZES/NWFSC
2725 Montlake Blvd. East
Seattle WA 98112-2097

Lauri Weitkamp
NMFS/NWFSC Coastal Zone & Estuari
Studies
2725 Montlake Blvd., East
Seattle WA 98112-2097

David Welch
Pacific Biological Station
Ocean Sciences and Productivity Div.
Nanaimo B.C. CANADA V9R 5K6

John Williams
NMFS/CZES/NWFSC
2725 Montlake Blvd. East
Seattle WA 98112-2097

Bruce Wing
NMFS, AFSC
7600 Sand Point Way NE
Seattle WA 98115

Rob Wolotira
Damage Assessment Restoration Center NW
7600 SAND PT WAY NE, Bldg 1
Seattle WA 98115

Warren Wooster
School of Marine Affairs
University of Washington
Seattle WA 98105-6715

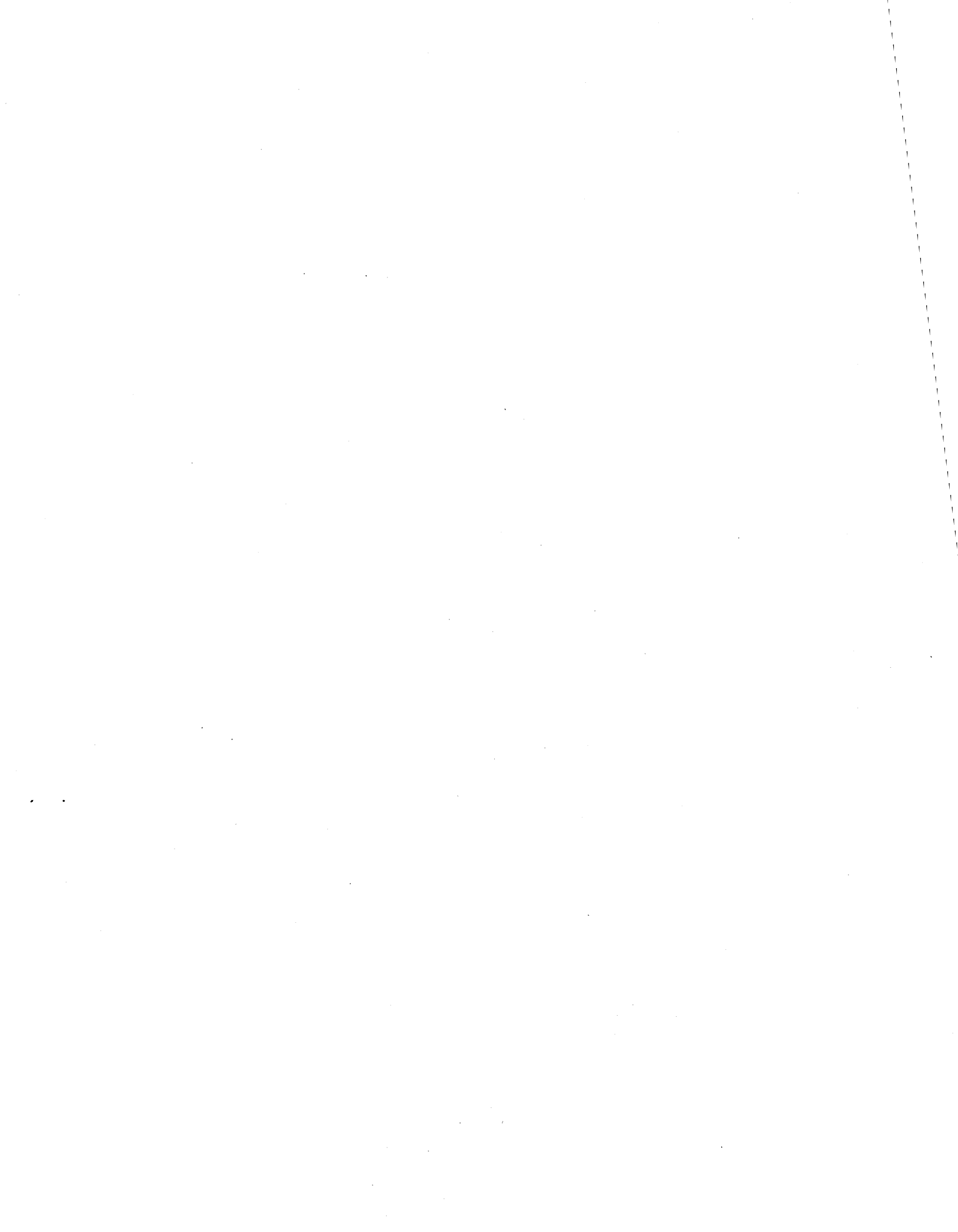



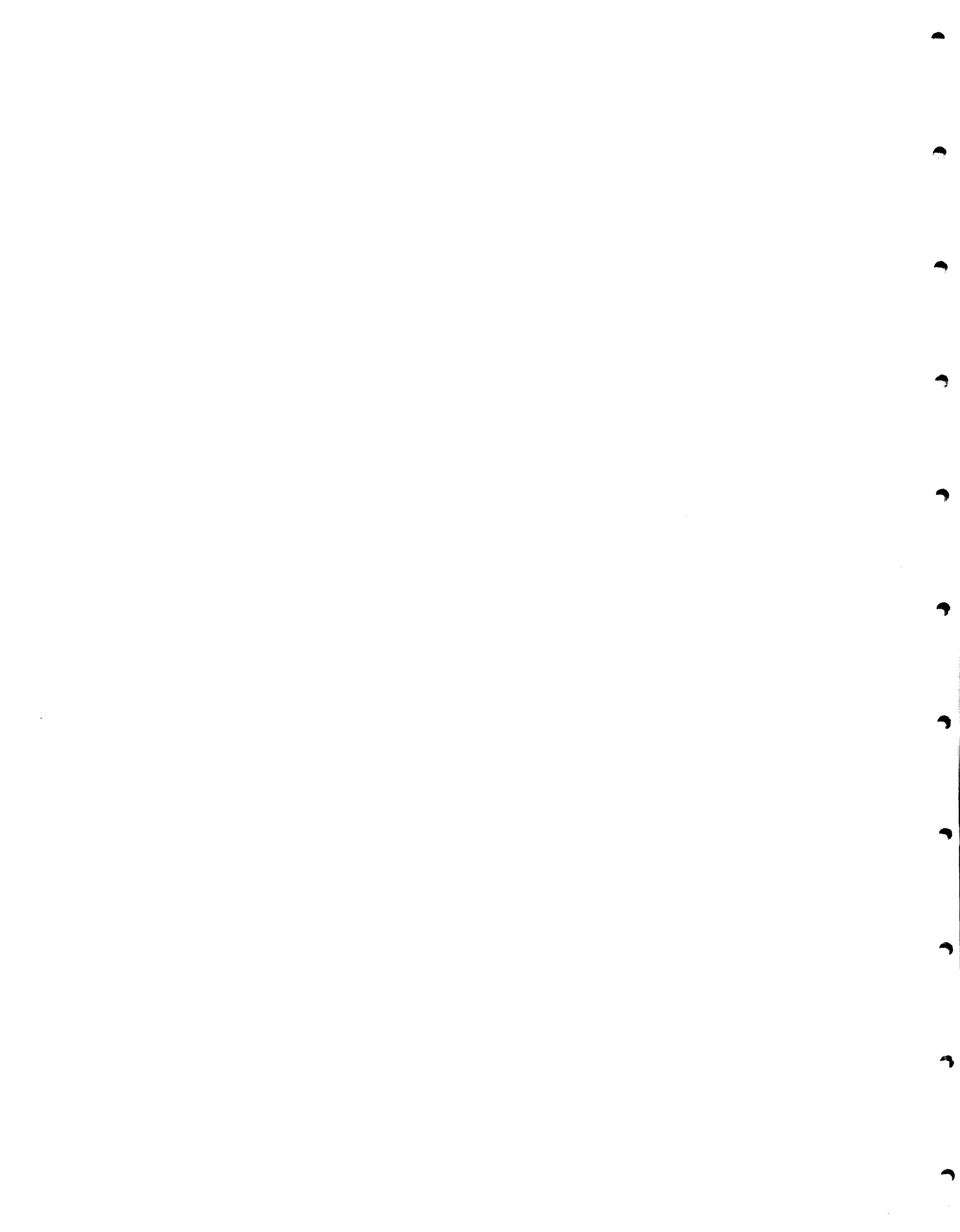

RECENT TECHNICAL MEMORANDUMS

Copies of this and other NOAA Technical Memorandums are available from the National Technical Information Service, 5285 Port Royal Road, Springfield, VA 22167. Paper copies vary in price. Microfiche copies cost \$3.50.

NMFS-NWFSC-

- 28 NATIONAL MARINE FISHERIES SERVICE (NMFS). 1997. Investigation of scientific information on the impacts of California sea lions and Pacific harbor seals on salmonids and on the coastal ecosystems of Washington, Oregon, and California, 172 p. NTIS number pending.
- 27 BUSBY, P. J., T. C. WAINWRIGHT, G. J. BRYANT, L. LIERHEIMER, R. S. WAPLES, F. W. WAKNITZ, and I. V. LAGOMARSINO. 1996. Status review of west coast steelhead from Washington, Idaho, Oregon, and California, 261 p. NTIS No. PB96-210166.
- 26 MCCABE, G. T., JR., and S. A. HINTON. 1996. Benthic invertebrates and sediment characteristics in freshwater, beach habitats of the lower Columbia River, 1994-95, 111p. NTIS No. PB96-186879.
- 25 HARD, J. J., R. G. KOPE, W. S. GRANT, F. W. WAKNITZ, L. T. PARKER, and R. S. WAPLES. 1996. Status review of pink salmon from Washington, Oregon, and California, 131 p. NTIS No. PB96-162607.
- 24 WEITKAMP, L. A., T. C. WAINWRIGHT, G. J. BRYANT, G. B. MILNER, D. J. TEEL, R. G. KOPE, and R. S. WAPLES. 1995. Status review of coho salmon from Washington, Oregon, and California, 258 p. NTIS No. PB96-106554.
- 23 HINTON, S. A., G. T. MCCABE, JR., and R. L. EMMETT. 1995. In-water restoration between Miller Sands and Pillar Rock Island, Columbia River: Environmental surveys, 1992-93, 47 p. NTIS No. PB95-274445.
- 22 WAKNITZ, F. W., G. M. MATTHEWS, T. WAINWRIGHT, and G. A. WINANS. 1995. Status review for mid-Columbia River summer chinook salmon, 80 p. NTIS No. PB95-260923.
- 21 REPPOND, K. D., and J. K. BABBITT. 1995. Frozen storage stability of fillets, mince, and mixed blocks prepared from unfrozen and previously frozen pink salmon (*Oncorhynchus gorbuscha*), 57 p. NTIS No. PB95-239828.
- 20 HINTON, S. A., and R. L. EMMETT. 1994. Juvenile salmonid stranding in the lower Columbia River, 1992 and 1993, 48 p. NTIS No. PB95-199352.
- 19 BUSBY, P. J., T. C. WAINWRIGHT, and R. S. WAPLES. 1994. Status review for Klamath Mountains Province steelhead, 130 p. NTIS No. PB95-179677.
- 18 GESSEL, M. H., B. P. SANDFORD, B. H. MONK, and D. A. BREGE. 1994. Population estimates of northern squawfish, *Ptychocheilus oregonensis*, at Bonneville Dam First Powerhouse, Columbia River, 21 p. NTIS No. PB95-198362.